

# MEphisto™ Scope 1 V1.1

## Block Diagram

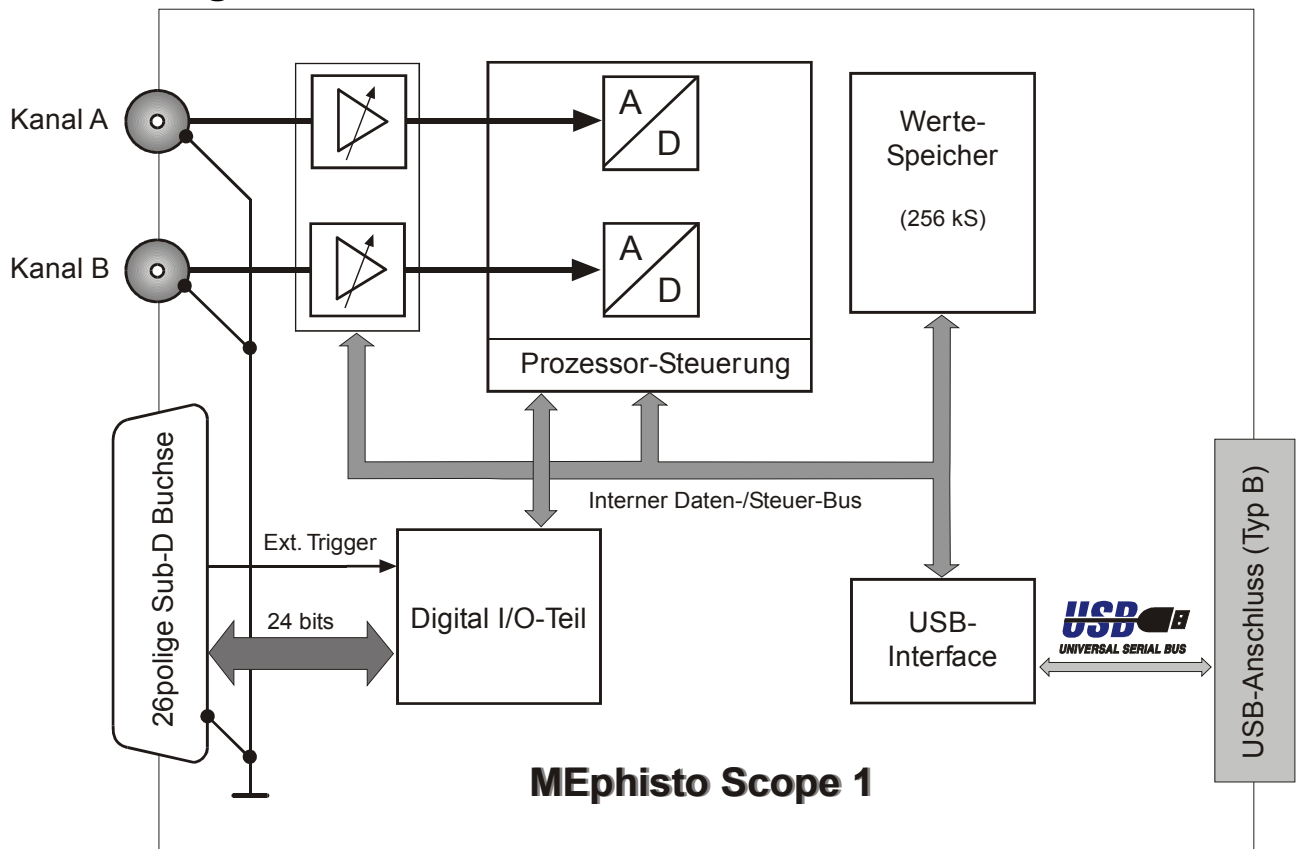

Features	UM202	UM203
acquisition modes		
voltmeter, DC	✓	✓
voltmeter, true RMS	✓	✓
analog oscilloscope	✓	✓
analog oscilloscope, stand alone		✓
analog data logger	✓	✓
analog data logger, stand alone		✓
logic analyzer	✓	✓
logic analyzer, stand alone		✓
digital data logger	✓	✓
digital data logger, stand alone		✓
mass storage		SD card up to 2 GB
real time clock		✓

## Technical Data

Voltmeter Mode	
analog channels	2
resolution	16 Bit
non linearity, integral	± 2 LSB
sampling rate	2 x 1 Sps
simultaneous channels	2
voltage range (in 1-2-5 steps)	± 100mV to ± 10V
analog bandwidth (-3dB) DC	40 kHz
RMS	2.3 kHz
accuracy (voltage) at 25°C / 77°F	0.1% or 1mV
accuracy (time)	100 ppm
overvoltage protection	± 300VDC
noise (typ.)	-94dB (RMS) -86dB (P-P)
input impedance	1 MΩ, 14 pF

Analog Oscilloscope Mode	
analog channels	2
resolution	16 Bit
non linearity, integral	± 2 LSB
sampling rate	2 x 1 MSps
sampling memory per channel	100 samples to 131000 samples
simultaneous channels	2
voltage range (in 1-2-5 steps)	± 100mV to ± 10V
analog bandwidth (-3dB)	500 kHz
automatic signal recognition	
voltage range	50mV <sub>pp</sub> – 20V <sub>pp</sub>
frequency range	0.2Hz – 500kHz
duty cycle, square wave, 100 Hz, 100 mV <sub>pp</sub>	0.2% - 99.8%
time base	1μs to 2.5s
(1μs/S to 10ms/S in 1μs steps, above this range 10ms/S steps)	
accuracy (voltage) at 25°C / 77°F	0.1% or 1mV
accuracy (time)	100 ppm
overvoltage protection	± 300VDC
noise (typ.)	-66dB (RMS) -48dB (P-P)
input impedance	1 MΩ, 14pF
trigger modes	6
level	✓
window	✓
edge	✓
dV/dt	✓
manual	✓
extern	✓
delay	✓

Logic Analyzer Mode	
digital channels	16
simultaneous channels	8+8
sampling memory per channel	100 samples to 262000 samples
simultaneous trigger channels	8
sampling rate	100 kSps
delay between the 8 bit groups	2 $\mu$ s
time base (10 $\mu$ s/S to 10ms/S in 1 $\mu$ s steps above this range 10ms/S steps)	10 $\mu$ s to 2.5s
accuracy (time)	100 ppm
logic level	5V CMOS (1.8V/3.3V CMOS; 12V/24V; with optional converter)
overvoltage protection	+5.5VDC/-0.5VDC
input impedance	50 M $\Omega$ , 8 pF
trigger modes	4
pattern (low / high / edge rising / edge falling / ignore) in any combination simultaneous for the lower 8 bit	✓
manual	✓
extern	✓
delay	✓

Analog Data Logger Mode	
analog channels	2
resolution	16 Bit
nonlinearity, integral	$\pm$ 2 LSB
sampling rate	2 x 100 kSps
simultaneous channels	2
voltage range (in 1-2-5 steps)	$\pm$ 100mV to $\pm$ 10V
analog bandwidth (-3dB)	500 kHz
time base (10 $\mu$ s/S to 10ms/S in 1 $\mu$ s steps above this range 10ms/S steps)	10 $\mu$ s to 2.5s
accuracy (voltage) at 25°C / 77°F	0.1% or 1mV
accuracy (time)	100 ppm
overvoltage protection	$\pm$ 300VDC
noise (typ.)	-66dB (RMS) -48dB (P-P)
input impedance	1 M $\Omega$ , 14 pF
trigger modes	6
level	✓
window	✓
edge	✓
dV/dt	✓
manual	✓
extern	✓
delay	✓

Digital Data Logger Mode	
digital channels	16
simultaneous channels	8+8
simultaneous trigger channels	8
sampling rate	
USB	100 kSps
SD card	2.5 kSps
delay between the 8 bit groups	2 $\mu$ s
time base	10 $\mu$ s to 2.5s (USB)
(10 $\mu$ s/S to 10ms/S in 1 $\mu$ s steps	400 $\mu$ s to 2.5s (SD)
above this range 10ms/S steps)	
accuracy (time)	100 ppm
logic level	5V CMOS (1.8V/3.3V CMOS; 12V/24V; with optional converter)
overvoltage protection	+5.5VDC/-0.5VDC
input impedance	50 M $\Omega$ , 8 pF
trigger modes	4
pattern (low / high / edge rising / edge falling / ignore)	✓
in any combination simultaneous for the lower 8 bit	
manual	✓
extern	✓
delay	✓

GPIO Mode (not available in logic analyzer mode)	
digital channels	24
resolution	1 Bit
direction programmable individually for each bit	✓
read back function for outputs	✓
logic level	5V CMOS

Device Data	
sample memory	512 kB
interface	USB 2.0 (FS), USB1.1 compatible
power supply	5V via USB, 5V via external power supply (UM203 only)
maximum power consumption, no load on digital channels	0.9W <sup>*)</sup>
connectors	
analog channels	2 * BNC
digital channels	1 * SUB-D-26 (HD)
USB	USB – B
external power supply (UM203 only)	DC plug, 5.5mm
SD card (UM203 only)	push-push slot
dimensions	
case	112 x 110 x 32 mm 4.41 x 4.33 x 1.26 in
including connectors	138 x 110 x 35 mm 5.43 x 4.33 x 1.38 in
weight	430 g 0.95 lb 15 oz
operating temperature	0...70°C 32..158°F
storage temperature	-20...85°C -4..185°F

<sup>\*)</sup> To ensure reliability with heavy load on the digital port, the device announces to have a power consumption of 2.5W with the operating system inquiry. Therefore it might not be activated when connected to a passive USB hub.

# System Requirements

Application		
<b>MEphisto Lab</b>	<b>minimal</b>	<b>recommended</b>
CPU class	Pentium III, 500MHz	Pentium IV, 2.4GHz
RAM		
Windows XP	128MB	256MB – 1GB
Windows Vista	512MB	1GB – 4GB
hard disk	700MB (FAT32), 400MB (NTFS)	1GB
graphics	1024x768 pixel (XGA), 256 colors (8Bit)	64k colors (16Bit) 1024x768 pixel (XGA) to 2048x1536 pixel (QXGA)
installation	CD ROM drive	CD ROM drive + internet
interface	USB 1.1	USB 1.1 – USB 2.0
operating system	Windows 2000	Windows 2000 Windows XP Windows Vista
<b>drivers only</b>	<b>minimal</b>	<b>recommended</b>
CPU class	80486, 100MHz	Pentium II, 200MHz
RAM	32MB	128MB
hard disk		ca. 5MB
interface	USB 1.1	USB 1.1 – USB 2.0
operating system		Windows 2000 Windows XP Windows Vista  <i>without support:</i> Windows 98SE Windows Me Linux Mac OS-X
<b>stand alone (UM203)</b>	<b>recommended</b>	
configuration process	depending on application	
PC	refer to either MEphistoLab or driver section	
running acquisition		
power supply	5VDC, > 250mA / > 1.3W	
mass storage	standard SD card, 8 MB up to 2 GB	