

Product Datasheet - Technical Specifications



More information in our Web-Shop at ► www.meilhaus.com

Your contact

Technical and commercial sales, price information,
quotations, demo/test equipment, consulting:

Tel.: **+49 - (0)81 41 - 52 71-0**

FAX: **+49 - (0)81 41 - 52 71-129**

E-Mail: sales@meilhaus.com

Meilhaus Electronic GmbH
Am Sonnenlicht 2
82239 Alling/Germany

Tel. **+49 - (0)81 41 - 52 71-0**
Fax **+49 - (0)81 41 - 52 71-129**
E-Mail sales@meilhaus.com

Mentioned company and product names may be registered trademarks of the respective companies. Errors and omissions excepted. © Meilhaus Electronic.

11713D/E Attenuator/Switch Drivers



This configuration guide will assist you through the process of configuring a switching system using the Keysight 11713D/E attenuator/switch drivers.

Key Features

The Keysight 11713D/E attenuator/switch drivers provide remote or front panel drive control for programmable attenuators and electromechanical or solid-state switches. Designed with both benchtop and ATE environments in mind, these attenuator/ switch drivers provide an intuitive user interface, a variety of switching options, software programmability and remote-control features for quick, easy design validation and automated testing. Front panel pushbuttons and an easy-to-read LCD display simplify setup of functions such as voltage, TTL functions, continuous or pulse-drive, IP address, etc. The 11713D/E is an LXI Class C compliant instrument, so it can be easily controlled and triggered remotely using a full-featured graphical web interface. This feature is used in high-volume production environments. Software instrument drivers such as IVI-COM provide programming compatibility with popular application development environments and support PC industry standards such as Component Object Model (COM). Standard GPIB connectivity supports automated programmed scripting and ensures backward compatibility to Keysight 11713B/C attenuator/switch drivers. These portable instruments come in a half-rack, 2U design with self-contained current limiting power supplies. The 11713E model also includes integrated tri-voltage supplies of 5, 15 & 24V and a user-defined external input voltage capability to ensure 100% biasing compatibility to most relays in the market. The 11713E has two individual banks of outputs each with an independent voltage drive.

- User-friendly interface provides quick set up, switching, and remote control of small-scale automated test equipment (ATE)
- Capability to drive Keysight's programmable attenuators, electro-mechanical or solid-state switches with continuous drive or pulse-drive selection
- Controls up to 20 SPDT switches¹ concurrently, or a combination of 4 programmable attenuators and 4 SPDT switches
- Multiple connectivity with LXI Class C compliance: GPIB, USB or LAN for easy remote integration
- An integrated, tri-voltage power supply saves rack space (11713E only)
- External VDC port connects any type of switch and provides forward compatibility for switches
- Backward compatibility with the Keysight Technologies 11713B/C
- Built-in counter monitors the life cycle of attenuators and switches

Model	11713D	11713E
Drives up to:	Two programmable attenuators and two electromechanical/solid state switches	Four programmable attenuators and four electro-mechanical/solid state switches
Drives up to:	10 SPDT switches ¹	20 SPDT switches ¹
Voltage	24 V	5, 15, 24 V & user selectable support voltages
Voltage drive	1 bank of output	2 independent banks of outputs
Attenuators types	Any attenuator or switch ²	Any attenuator or switch ²
Switch types	Any attenuator or switch ²	Any attenuator or switch ²
Connectivity	GPIB, USB, LAN (LXI Class C)	GPIB, USB, LAN (LXI Class C)
Backwards compatibility	Yes (with 11713B)	Yes (with 11713C)

1. The number of switches and attenuators that can be driven will depend on the type of switch configurations and the attenuator sections. The 11713E capable of driving twice as many devices as the 11713D; however, the total load current that can be consumed is still 3.4A.

2. Accepts most attenuators and switches available today. Including supporting solid state switches. Do not support 85331/2B solid state switches and 8761A/B switches.

11713D/E System Specification

Specifications describe warranted performance over the temperature range 0 to +55 °C after one hour of continuous operation, unless otherwise noted.

Drive power Supply	11713D
Current	3.4 A maximum continuous current Contact pairs 1 through 8, 9, and 0, total maximum current of 3.4 A continuous through all contacts (< 0.7 A per contact)

11713D/E Remote Programming

Drive power supply	11713D/E
Interface	GPIB interface operates to IEEE 488.2 and IEC65 10/100 BaseT LAN interface USB 2.0 interface
Command language	SCPI standard interface commands (Keysight 11713B/C backward compatible)
GPIB compatibility	SH0, AH1, T0, TE0, L2, LE0, SR0, RL1, PP0, DC0, DT0, C0

11713D/E Supplemental Specifications and Characteristics

Supplemental characteristics are intended to provide useful information. They are typical but non-warranted performance parameters

Drive power supply	11713D/E
Power	100 to 240 Vac, automatic selection, 50/60 Hz 160 VA maximum Mains supply voltage fluctuations are not to exceed 10% of the nominal supply voltage
Maximum load inductance	500 mH
Maximum load capacitance	< 0.01 uF for contact pairs 9 and 0

Mechanical Information

11713D product dimensions	
Net weight	With rubber bumper and handle: 3.5 kg (7.7 lbs) Without rubber bumper and handle: 3.1 kg (6.8 lbs)
Dimension (H x W x D) with handle and rubber bumper	103.0 mm x 261.3 mm x 378.7 mm (4.06 inches x 10.29 inches x 14.91 inches)
Dimension (H x W x D) without handle and rubber bumper	87.7 mm x 212.7 mm x 364.1 mm (3.45 inches x 8.37 inches x 14.34 inches)

11713E product dimensions	
Net weight	With rubber bumper and handle: 3.6 kg (7.9 lbs) Without rubber bumper and handle: 3.2 kg (7.1 lbs)
Dimension (H x W x D) with handle and rubber bumper	103.0 mm x 261.3 mm x 378.7 mm (4.06 inches x 10.29 inches x 14.91 inches)
Dimension (H x W x D) without handle and rubber bumper	87.7 mm x 212.7 mm x 364.1 mm (3.45 inches x 8.37 inches x 14.34 inches)

Product Configuration

The 11713D/E attenuator/switch drivers can be configured easily. The connection between the driver and switching devices is intuitive and direct. Simply select the appropriate interface cable and you can make point-to-point connection from the driver to the attenuator(s) and/or switch(es). Details such as pin numbers and wires color are provided in the tables found in Configuration Information for Switches and Configuration Information for Attenuators sections.

Note 1: The maximum quantity orderable for each cable option is 9.

Note 2: The length of cables below is 60 inches (5 ft).

11713D/E	Part Number	Description
Cable Options		
Option 001	11764-60004	Viking connector to 10-pin DIP connector
Option 101	8120-2703	Viking connector to viking connector
Option 102	11713-60068	Viking connector to 4 cables with 4-conductor bare wires
Option 103	11713-60069	Viking connector to 2 cables with 5-conductor bare wires
Option 104	11713-60071	Viking connector to 4 cables with 3-pin connector
Option 105	11713-60072	Viking connector to 4 cables with 3-conductor bare wires
Option 106	11713-60073	Dual Viking connector to 24-pin connector
Option 107	11713-60074	Triple Viking connector to 24-pin connector
Option 201	5061-0969	Viking connector to 12-pin conductor cable, bare wire
Option 301	11761-60001	Viking connector to (4) ribbon cables
Option 401	11713-60042	Dual-viking connector to 16-pin DIP connector
Option 501	11713-60043	Viking connector to (4) 9-pin Dsub connectors
Option 502	11713-60049	Viking connector to (2) 9-pin Dsub connectors
Option 601	11713-60044	Viking connector to 16-pin DIP connector
Option 701	5064-7848	Viking connector to 14-pin DIP connector
Option 801	11713-60047	Viking connector to (4) 10-pin DIP connectors
Rack mount kit options (optional)		
Option 908	5063-9240	Rack mount kit for one instrument
Option 909	5061-9694 & 5063-9212	Rack mount kit for two instruments

Five Simple Steps to Configure your Switching System

1. Determine the switching device's model and option (DC connector).

Example

Model: 87104A (SP4T switch)

Option: 100 (solder terminal)

2. Determine the attenuator/switch driver's model and option (interface cable).

Example

Model: 11713D

Option: 201 (Viking connector to 12-pin conductor cable, bare wire)

3. Use the selection guide, Table A (page 6) for switches and Table B (page 7) for attenuators,

Example

Selection guide: Table A (for switches)

Configuration table: Table F-1

Switches	Model	Option	11713D/E			
			001	101	201	601
SP4T	87104A/B/C/D/P/Q/R	100			Table F-1	
		161				Table F-2
	87204A/B/C	100			Table G-1	
		161				Table G-2
	L7104A/B/C	100			Table F-1	
		161				Table F-2
	L7204A/B/C	100			Table F-1	
		161				Table F-2
	8767K	016	Table J-1			
		060		Table J-2		
8767M	No option	Table L				

4. Configure your switching system using Table F-1 (page 13) as a reference.

From 11713D/E (Option 201)				To 87104A/B/C/D, 87104P/Q/R, L7104A/B/C & L7204A/B/C SP4T (Option 100)	
Front panel pushbutton		Interface cable		Solder terminal number	RF path
Attenuator X	LED	Viking connector pin number	Bare wire color		
–	–	1 (VCC)	Red	1	–
–	–	2 (GND)	White/Brown	15	–
1	OFF	5	Violet	5	2 to C closed
2	OFF	7	Black	7	3 to C closed
3	OFF	9	Orange	11	5 to C closed
4	OFF	11	Brown	13	6 to C closed

5. Operate your system.

Table A: Selection guide for switches

Electro-mechanical switches

Switches	Model	Option	11713D/E		
			201	501	502
Bypass	8763A/B/C	001/015/024	Table D-2		
		T15/T24	Table D-5		
	8764A/B/C	011/015/024	Table D-3		
		T15/T24	Table D-6		
	N1811T, N1811TL	202	Table O-11		
		201		Table O-12	
		202/401	Table O-15		
		201/401			Table O-16
	N1812U, N1812UL	202	Table O-9		
		201		Table O-10	
		202/401	Table O-13		
		201/401			Table O-14

Switches	Model	Option	11713D/E			
			201	301	501	502
SPDT	8762A/B/C/F	011/015/024	Table D-1			
		T5/T24	Table D-4			
	8765A/B/C/D, 8765F ¹	305/310/315/324	Table E-1			
		005/010/015/024		Table E-2		
	N1810U, N1810UL	202	Table O-1			
		201			Table O-2	
		202/401	Table O-5			Table O-6
		201/401				
	N1810T, N1810TL	202	Table O-3			
		201			Table O-4	
		202/401	Table O-7			
		201/401				Table O-8

Switches	Model	Option	11713D/E	
			001	101
SP3T	8766K	016	Table J-1	
		060		Table J-2

Switches	Model	Option	11713D/E			
			001	101	201	601
SP4T	87104A/B/C/D/P/Q/R	100			Table F-1	
		161				Table F-2
	87204A/B/C	100			Table G-1	
		161				Table G-2
	L7104A/B/C	100			Table F-1	
		161				Table F-2
	L7204A/B/C	100			Table F-1	
		161				Table F-2
	8767K	016	Table J-1			
		060		Table J-2		
8767M	No option	Table L				

Switches	Model	Option	11713D/E	
			001	101
SP5T	8768K	016	Table J-1	
		060		Table J-2
	8768M	No option	Table L	

Switches	Model	Option	11713D/E			
			101	201	401	701
SP6T	87106A/B/C/D/P/Q/R	100		Table H-1		
		161			Table H-2	
	87206A/B/C	100		Table I-1		
		161			Table I-2	
	L7106A/B/C	100		Table H-1		
		161			Table H-2	
	L7206A/B/C	100		Table H-1		
		161			Table H-2	
	8769K	060	Table K			
	8769M	No option				Table M

Switches	Model	Option	11713D/E		
			106	107	201
SP8T	U7108A/B/C	200	Table P-1		
		300	Table P-1		
		400			Table P-2
		500			Table P-2
SP10T	U7110A/B/C	200		Table P-3	
		300		Table P-3	
		400			Table P-4
		500			Table P-4

Switches	Model	Option	11713D/E	
			201	401
Matrix	87406B/Q	100	Table H-1	
		161		Table H-2
	87606B/Q	100	Table I-1	
		161		Table I-2

Switches	Model	Option	201	801
Transfer	87222C/D/E/R	100	Table N-1	
		161		Table N-2
	L7222C	100	Table N-1	
		161		Table N-2

1. 8765A/B/C/D/F require continuous current to latch. The number of switches for connection depends on option selection.

Switch Option Descriptions

- 011: 5 Vdc
- 015: 15 Vdc
- 024: 24 Vdc
- T15: TTL/5V CMOS compatible logic with 15 Vdc supply
- T24: TTL/5V CMOS compatible logic with 24 Vdc supply
- 200: Standard 24 VDC and 24-PIN DIP DC connector with-24 inch ribbon cable, bare wire
- 300: TTL 24 VDC and 24-PIN DIP DC connector with 24-inch ribbon cable, bare wire
- 400: Standard 24 VDC and Solder Terminals
- 500: TTL 24 VDC and Solder Terminals
- 201: D-submini 9 pin (f)
- 202: Solder lug
- 401: TTL/5V CMOS compatible
- 305: 5 Vdc with solder terminals
- 310: 10 Vdc with solder terminals
- 315: 15 Vdc with solder terminals
- 324: 24 Vdc with solder terminals
- 005: 5 Vdc with 3-inch ribbon cable
- 010: 10 Vdc with 3-inch ribbon cable
- 016: 16-inch ribbon cables
- 060: Viking cable connector
- 100: Solder terminals
- 161: Ribbon receptacle

Solid state switches

Solid State Switches	Models	Option	11713D/E				
			102	103	104	105	201
SPDT	U9397A/C	No option				Table V	
	P9402A/C	No option		Table T			
SP4T	P9404A/C	No option					Table W
Transfer	P9400A/C	No option	Table S				
	U9400A/C	No option			Table U		

Table B: Selection guide for attenuators

Attenuators Model	Option	001	101
8494G/H	016	Table Q-1	
	060		Table Q-2
8495G/H	016	Table Q-1	
	060		Table Q-2
8496G/H	016	Table Q-1	
	060		Table Q-2
8495K	016	Table Q-1	
	060		Table Q-2
8497K	016	Table Q-1	
	060		Table Q-2
84904K/L/M	No option	Table R	
84905M	No option	Table R	
84906K/L	No option	Table R	
84907K/L	No option	Table R	
84908M	No option	Table R	

Attenuator Option Description

Option 060: 12-pin Viking connector

Option 016: 16-inch ribbon cable with 14-pin DIP plug

Configuration Information for Switches

Electro-mechanical switches

Note 1: Each table below illustrates the configuration of five switches to the 11713D/E.

Note 2: Five additional switches can be driven by Attenuator Y (front panel pushbuttons 5, 6, 7, 8 & 0) using the same configuration as Attenuator X.

Table D-1: Configuration of 11713D/E (Option 201) to 8762A/B/C/F SPDT switches (Option 005/011/024)

From 11713D/E (Option 201)				To 8762A/B/C/F (Option 005/011/024)		
Front panel pushbutton		Interface cable		To 8762A/B/C/F (Option 005/011/024)		
Attenuator X	LED	Viking connector pin number	Bare wire color	Solder terminal number	RF path	Device under test (DUT)
–	–	1 (VCC)	Red	C	–	VCC for all 5 DUTs
1	OFF	5	Violet	1	1 to C closed, 2 terminated	DUT 1
	ON	6	Yellow	2	2 to C closed, 1 terminated	
2	OFF	7	Black	1	1 to C closed, 2 terminated	DUT 2
	ON	8	Green	2	2 to C closed, 1 terminated	
3	OFF	9	Orange	1	1 to C closed, 2 terminated	DUT 3
	ON	10	Blue	2	2 to C closed, 1 terminated	
4	OFF	11	Brown	1	1 to C closed, 2 terminated	DUT 4
	ON	12	White	2	2 to C closed, 1 terminated	
9	OFF	4	Gray	1	1 to C closed, 2 terminated	DUT 5
	ON	3	White/Red	2	2 to C closed, 1 terminated	

Table D-2: Configuration of 11713D/E (Option 201) to 8763A/B/C bypass switches (Option 005/011/024)

From 11713D/E (Option 201)				To 8763A/B/C (Option 005/011/024)		
Front panel pushbutton		Interface cable		To 8763A/B/C (Option 005/011/024)		
Attenuator X	LED	Viking connector pin number	Bare wire	Solder terminal number	RF path	Device under test (DUT)
–	–	1 (VCC)	color Red	C	–	VCC for all 5 DUTs
1	OFF	5	Violet	1	1 to 2 closed, 3 to 4 closed	DUT 1
	ON	6	Yellow	2	1 terminated, 2 to 3 closed, 4 open	
2	OFF	7	Black	1	1 to 2 closed, 3 to 4 closed	DUT 2
	ON	8	Green	2	1 terminated, 2 to 3 closed, 4 open	
3	OFF	9	Orange	1	1 to 2 closed, 3 to 4 closed	DUT 3
	ON	10	Blue	2	1 terminated, 2 to 3 closed, 4 open	
4	OFF	11	Brown	1	1 to 2 closed, 3 to 4 closed	DUT 4
	ON	12	White	2	1 terminated, 2 to 3 closed, 4 open	
9	OFF	4	Gray	1	1 to 2 closed, 3 to 4 closed	DUT 5
	ON	3	White/Red	2	1 terminated, 2 to 3 closed, 4 open	

Table D-3 Configuration of 11713D/E (Option 201) to 8764A/B/C bypass switches (Option 005/011/024)

From 11713D/E (Option 201)				To 8764A/B/C (Option 005/011/024)		
Front panel pushbutton		Interface cable				
Attenuator X	LED	Viking connector pin number	Bare wire	Solder terminal number	RF path	Device under test (DUT)
–	–	1 (VCC)	color Red	C	–	VCC for all 5 DUTs
1	OFF	5	Violet	1	1 open, 2 to 3 closed, 4 to 5 closed	DUT 1
	ON	6	Yellow	2	1 to 2 closed, 3 to 4 closed, 5 open	
2	OFF	7	Black	1	1 open, 2 to 3 closed, 4 to 5 closed	DUT 2
	ON	8	Green	2	1 to 2 closed, 3 to 4 closed, 5 open	
3	OFF	9	Orange	1	1 open, 2 to 3 closed, 4 to 5 closed	DUT 3
	ON	10	Blue	2	1 to 2 closed, 3 to 4 closed, 5 open	
4	OFF	11	Brown	1	1 open, 2 to 3 closed, 4 to 5 closed	DUT 4
	ON	12	White	2	1 to 2 closed, 3 to 4 closed, 5 open	
9	OFF	4	Gray	1	1 open, 2 to 3 closed, 4 to 5 closed	DUT 5
	ON	3	White/Red	2	1 to 2 closed, 3 to 4 closed, 5 open	

Note 1: Each table below illustrates the configuration of five switches to the 11713D/E.

Note 2: Five additional switches can be driven by Attenuator Y (front panel pushbuttons 5, 6, 7, 8 & 0) using the same configuration as Attenuator X.

Table D-4: Configuration of 11713D/E (Option 201) to 8762A/B/C SPDT switches (Option T15/T24)

From 11713D/E (Option 201)				To 8762A/B/C (Option T15/T24)		
Front panel pushbutton		Interface cable				
Attenuator X	LED	Viking Connector Pin Number	Bare Wire Color	Solder Terminal Number	RF Path	Device Under Test (DUT)
–	–	1 (VCC)	Red	C	–	VCC for all 5 DUTs
–	–	2 (GND)	White/Brown	2	–	GND for all 5 DUTs
1	OFF	5	Violet	1	1 to C closed, 2 terminated	DUT 1
	ON				2 to C closed, 1 terminated	
2	OFF	7	Black	1	1 to C closed, 2 terminated	DUT 2
	ON				2 to C closed, 1 terminated	
3	OFF	9	Orange	1	1 to C closed, 2 terminated	DUT 3
	ON				2 to C closed, 1 terminated	
4	OFF	11	Brown	1	1 to C closed, 2 terminated	DUT 4
	ON				2 to C closed, 1 terminated	
9	OFF	4	Gray	1	1 to C closed, 2 terminated	DUT 5
	ON				2 to C closed, 1 terminated	

Table D-5: Configuration of 11713D/E (Option 201) to 8763A/B/C bypass switches (Option T15/T24)

From 11713D/E (Option 201)				To 8763A/B/C (Option T15/T24)		
Front panel pushbutton		Interface cable		Solder Terminal Number	RF Path	Device Under Test (DUT)
Attenuator X	LED	Viking Connector Pin Number	Bare Wire Color			
–	–	1 (VCC)	Red	C	–	VCC for all 5 DUTs
–	–	2 (GND)	White/Brown	2	–	GND for all 5 DUTs
1	OFF	5	Violet	1	1 to 2 closed, 3 to 4 closed	DUT 1
	ON				1 terminated, 2 to 3 closed, 4 open	
2	OFF	7	Black	1	1 to 2 closed, 3 to 4 closed	DUT 2
	ON				1 terminated, 2 to 3 closed, 4 open	
3	OFF	9	Orange	1	1 to 2 closed, 3 to 4 closed	DUT 3
	ON				1 terminated, 2 to 3 closed, 4 open	
4	OFF	11	Brown	1	1 to 2 closed, 3 to 4 closed	DUT 4
	ON				1 terminated, 2 to 3 closed, 4 open	
9	OFF	4	Gray	1	1 to 2 closed, 3 to 4 closed	DUT 5
	ON				1 terminated, 2 to 3 closed, 4 open	

Table D-6: Configuration of 11713D/E (Option 201) to 8764A/B/C bypass switches (Option T15/T24)

From 11713D/E (Option 201)				To 8764A/B/C (Option T15/T24)		
Front panel pushbutton		Interface cable		Solder Terminal Number	RF Path	Device Under Test (DUT)
Attenuator X	LED	Viking Connector Pin Number	Bare Wire Color			
–	–	1 (VCC)	Red	C	–	VCC for all 5 DUTs
–	–	2 (GND)	White/Brown	2	–	GND for all 5 DUTs
1	OFF	5	Violet	1	1 open, 2 to 3 closed, 4 to 5 closed	DUT 1
	ON				1 to 2 closed, 3 to 4 closed, 5 open	
2	OFF	7	Black	1	1 open, 2 to 3 closed, 4 to 5 closed	DUT 2
	ON				1 to 2 closed, 3 to 4 closed, 5 open	
3	OFF	9	Orange	1	1 open, 2 to 3 closed, 4 to 5 closed	DUT 3
	ON				1 to 2 closed, 3 to 4 closed, 5 open	
4	OFF	11	Brown	1	1 open, 2 to 3 closed, 4 to 5 closed	DUT 4
	ON				1 to 2 closed, 3 to 4 closed, 5 open	
9	OFF	4	Gray	1	1 open, 2 to 3 closed, 4 to 5 closed	DUT 5
	ON				1 to 2 closed, 3 to 4 closed, 5 open	

Note 1: Each table below illustrates the configuration of five switches to the 11713D/E.

Note 2: The number of switches available for connection depends on option selection.

Note 3: Five switches can be driven by Attenuator Y (front panel pushbuttons 5, 6, 7, 8 & 0) using the same configuration as Attenuator X.

Table E-1: Configuration of 11713D/E (Option 201) to 8765A/B/C/D/F SPDT switches (Options 3xx)

From 11713D/E (Option 201)				To 8765A/B/C/D/F (Option 305/310/315/324)		
Front panel pushbutton		Interface cable				
Attenuator X	LED	Viking connector pin number	Bare wire color	Solder terminal number	RF path	Device under test (DUT)
-	-	1 (VCC)	Red	2 and 3	-	VCC for all 5 DUTs
1	OFF	5	Violet	1	2 to C closed, 1 open	DUT 1
	ON	6	Yellow	4	1 to C closed, 2 open	
2	OFF	7	Black	1	2 to C closed, 1 open	DUT 2
	ON	8	Green	4	1 to C closed, 2 open	
3	OFF	9	Orange	1	2 to C closed, 1 open	DUT 3
	ON	10	Blue	4	1 to C closed, 2 open	
4	OFF	11	Brown	1	2 to C closed, 1 open	DUT 4
	ON	12	White	4	1 to C closed, 2 open	
9	OFF	4	Gray	1	2 to C closed, 1 open	DUT 5
	ON	3	White/Red	4	1 to C closed, 2 open	

Table E-2: Configuration of 11713D/E (Option 301) to 8765A/B/C/D/F SPDT switches (Options 0xx)

From 11713D/E (Option 301)				To 8765A/B/C/D/F (Option 005/010/015/024)		
Front panel pushbutton		Interface cable				
Attenuator X	LED	Viking connector pin number/ banana jack (rear panel)	5-pin receptacle pin number	Ribbon cable connector pin number	RF path	Device under test (DUT)
-	-	1 (VCC)/VDC COM	3 and 4	3 and 4	-	VCC for all 5 DUTs
1	OFF	5	1	1	2 to C closed, 1 open	DUT 1
	ON	6	5	5	1 to C closed, 2 open	
2	OFF	7	1	1	2 to C closed, 1 open	DUT 2
	ON	8	5	5	1 to C closed, 2 open	
3	OFF	9	1	1	2 to C closed, 1 open	DUT 3
	ON	10	5	5	1 to C closed, 2 open	
4	OFF	11	1	1	2 to C closed, 1 open	DUT 4
	ON	12	5	5	1 to C closed, 2 open	
9	OFF	S9-A	—	1	2 to C closed, 1 open	DUT 5
	ON	S9-B	—	5	1 to C closed, 2 open	

Note 1: Each table below illustrates the configuration of one switch to the 11713D/E.

Note 2: For switches with Option 161, ground pin 16 open all paths. Use S9 for Attenuator X or S0 for Attenuator Y. Do not close any path and ground pin 16 simultaneously as this makes the switch buzz. *

Note 3: For switches with Option 100, there are no solder terminals available to open all paths.

Note 4: Solder terminal/DIP connector with pin numbers 6, 8, 12 & 14 provides indicator function.

Note 5: Applies to both Option 024 (standard/non-TTL drive) and Option T24 (TTL drive).

Note 6: One additional switch can be driven by Attenuator Y (front panel pushbuttons 5, 6, 7 & 8) using the same configuration as Attenuator X.

Table F-1: Configuration of 11713D/E (Option 201) to 87104A/B/C/D, 87104P/Q/R, L7104A/B/C & L7204A/B/C SP4T switches (Option 100)

From 11713D/E (Option 201)				To 87104A/B/C/D, 87104P/Q/R, L7104A/B/C & L7204A/B/C SP4T (Option 100)	
Front panel pushbutton		Interface cable			
Attenuator X	LED	Viking connector pin number	Bare wire color	Solder terminal number	RF path
–	–	1 (VCC)	Red	1	–
–	–	2 (GND)	White/Brown	15	–
1	OFF	5	Violet	5	2 to C closed
2	OFF	7	Black	7	3 to C closed
3	OFF	9	Orange	11	5 to C closed
4	OFF	11	Brown	13	6 to C closed

Table F-2: Configuration of 11713D/E (Option 601) to 87104A/B/C/D, 87104P/Q/R, L7104A/B/C & L7204A/B/C SP4T switches (Option 161)

From 11713D/E (Option 601)				To 87104A/B/C/D, 87104P/Q/R, L7104A/B/C & L7204A/B/C SP4T (Option 161)	
Front panel pushbutton		Interface cable			
Attenuator X	LED	Viking connector pin number	16-pin DIP pin number	RF path	
–	–	1 (VCC)	1	–	
–	–	2 (GND)	15	–	
1	OFF	5	5	2 to C closed	
2	OFF	7	7	3 to C closed	
3	OFF	9	11	5 to C closed	
4	OFF	11	13	6 to C closed	

Note 1: Each table below illustrates the configuration of one switch to the 11713D/E.

Note 2: For switches with Option 161, ground pin 16 opens all paths. Use S9 for Attenuator X or S0 for Attenuator Y. Do not close any path and ground pin 16 simultaneously as this makes the switch to buzz. *

Note 3: For switch with Option 100, no solder terminal available to open all paths.

Note 4: Applies to both Option 024 (standard/non-TTL drive) and Option T24 (TTL drive).

Note 5: One additional switch can be driven by Attenuator Y (front panel pushbuttons 5, 6, 7 & 8) using the same configuration as Attenuator X.

Table G-1: Configuration of 11713D/E (Option 201) to 87204A/B/C SP4T switches (Option 100)

From 11713D/E (Option 201)				To 87204A/B/C (Option 100)	
Front panel pushbutton		Interface cable			
Attenuator X	LED	Viking connector pin number	Bare wire color	Solder terminal number	RF path
–	–	1 (VCC)	Red	1	–
–	–	2 (GND)	White/Brown	15	–
1	OFF	5	Violet	5	2 to C closed
	ON	6	Yellow	6	2 to C opened
2	OFF	7	Black	7	3 to C closed
	ON	8	Green	8	3 to C opened
3	OFF	9	Orange	11	5 to C closed
	ON	10	Blue	12	5 to C opened
4	OFF	11	Brown	13	6 to C closed
	ON	12	White	14	6 to C opened

Table G-2: Configuration of 11713D/E (Option 601) to 87204A/B/C SP4T switches (Option 161)

From 11713D/E (Option 601)				To 87204A/B/C (Option 161)	
Front panel pushbutton		Interface cable			
Attenuator X	LED	Viking connector pin number	16-pin DIP pin number	RF path	
–	–	1 (VCC)	1	–	
–	–	2 (GND)	15	–	
1	OFF	5	5	2 to C closed	
	ON	6	6	2 to C opened	
2	OFF	7	7	3 to C closed	
	ON	8	8	3 to C opened	
3	OFF	9	11	5 to C closed	
	ON	10	12	5 to C opened	
4	OFF	11	13	6 to C closed	
	ON	12	14	6 to C opened	

Note 1: Each table below illustrates the configuration of one switch to the 11713D/E.

Note 2: For switches with Option 161, ground pin 16 opens all paths. Use S9 for Attenuator X or S0 for Attenuator Y. Do not close any path and ground pin 16 simultaneously as this makes the switch to buzz. *

Note 3: For switch with Option 100, no solder terminal available to open all paths.

Note 4: Solder terminal/DIP connector with pin numbers 4, 6, 8, 10, 12 & 14 provides indicator function.

Note 5: Applies to both Option 024 (standard/non-TTL drive) and Option T24 (TTL drive).

Table H-1: Configuration of 11713D/E (Option 201) to 87106A/B/C/D, 87106P/Q/R, L7106A/B/C & L7206A/B/C SP6T switches (Option 100) and 87406B/Q matrix switch (Option 100)

From 11713D/E (Option 201 - quantity 2)				To 87106A/B/C/D, 87106P/Q/R, L7106A/B/C & L7206A/B/C SP6T and 87406B/Q (Option 100)	
Front panel pushbutton		Interface cable			
Attenuator X/Y	LED	Viking connector pin number	Bare wire color	Solder terminal number	RF path
–	–	1 (VCC)	Red	1	–
–	–	2 (GND)	White/Brown	15	–
1	OFF	Cable 1-5	Violet	3	1 to C closed
2	OFF	Cable 1-7	Black	5	2 to C closed
3	OFF	Cable 1-9	Orange	7	3 to C closed
4	OFF	Cable 1-11	Brown	9	4 to C closed
5	OFF	Cable 2-5	Violet	11	5 to C closed
6	OFF	Cable 2-7	Black	13	6 to C closed

Table H-2: Configuration of 11713D/E (Option 401) to 87106A/B/C/D, 87106P/Q/R, L7106A/B/C & L7206A/B/C SP6T switches (Option 161) and 87406B/Q matrix switch (Option 161)

From 11713D/E (Option 401)				To 87106A/B/C/D, 87106P/Q/R, L7106A/B/C & L7206A/B/C SP6T and 87406B/Q (Option 161)	
Front panel pushbutton		Interface cable			
Attenuator X/Y	LED	Viking connector pin number	16-pin DIP pin number	RF path	
–	–	1 (VCC)	1	–	
–	–	2 (GND)	15	–	
1	OFF	P1-5	3	1 to C closed	
2	OFF	P1-7	5	2 to C closed	
3	OFF	P1-9	7	3 to C closed	
4	OFF	P1-11	9	4 to C closed	
5	OFF	P2-5	11	5 to C closed	
6	OFF	P2-7	13	6 to C closed	

Note 1: Each table below illustrates the configuration of one switch to the 11713D/E.

Note 2: For switches with Option 161, ground pin 16 opens all paths. Use S9 for Attenuator X or S0 for Attenuator Y. Do not close any path and ground pin 16 simultaneously as this makes the switch to buzz. *

Note 3: For switch with Option 100, no solder terminal available to open all paths.

Note 4: Applies to both Option 024 (standard/non-TTL drive) and Option T24 (TTL drive).

Table I-1: Configuration of 11713D/E (Option 201) to 87206A/B/C SP6T switches (Option 100) & 87606B/Q matrix switch (Option 100)

From 11713D/E (Option 201 - quantity 2)				To 87206A/B/C & 87606B/Q (Option 100)	
Front panel pushbutton		Interface cable			
Attenuator X/Y	LED	Viking connector pin number	Bare wire color	Solder terminal number	RF path
–	–	1 (VCC)	Red	1	–
–	–	2 (GND)	White/Brown	15	–
1	OFF	Cable 1-5	Violet	3	1 to C closed
	ON	Cable 1-6	Yellow	4	1 to C opened
2	OFF	Cable 1-7	Black	5	2 to C closed
	ON	Cable 1-8	Green	6	2 to C opened
3	OFF	Cable 1-9	Orange	7	3 to C closed
	ON	Cable 1-10	Blue	8	3 to C opened
4	OFF	Cable 1-11	Brown	9	4 to C closed
	ON	Cable 1-12	White	10	5 to C opened
5	OFF	Cable 2-5	Violet	11	5 to C closed
	ON	Cable 2-6	Yellow	12	5 to C opened
6	OFF	Cable 2-7	Black	13	6 to C closed
	ON	Cable 2-8	Green	14	6 to C opened

Table I-2: Configuration of 11713D/E (Option 401) to 87206A/B/C SP6T switches (Option 161) & 87606B/Q matrix switch (Option 161)

From 11713D/E (Option 401)				To 87206A/B/C & 87606B/Q (Option 161)	
Front panel pushbutton		Interface cable			
Attenuator X/Y	LED	Viking connector pin number	16-pin DIP pin number	RF path	
–	–	1 (VCC)	1	–	
–	–	2 (GND)	15	–	
1	OFF	P1-5	3	1 to C closed	
	ON	P1-6	4	1 to C opened	
2	OFF	P1-7	5	2 to C closed	
	ON	P1-8	6	2 to C opened	
3	OFF	P1-9	7	3 to C closed	
	ON	P1-10	8	3 to C opened	
4	OFF	P1-11	9	4 to C closed	
	ON	P1-12	10	4 to C opened	
5	OFF	P2-5	11	5 to C closed	
	ON	P2-6	12	5 to C opened	
6	OFF	P2-7	13	6 to C closed	
	ON	P2-8	14	6 to C opened	

Note 1: Each table below illustrates the configuration of one switch to the 11713D/E.

Note 2: With assumption that the initial state of switch's RF path is thru.

Note 3: One additional switch can be driven by Attenuator Y (front panel pushbuttons 5, 6, 7 & 8) using the same configuration as Attenuator X.

Table J-1: Configuration of 11713D/E (Option 001) to 8766K, 8767K & 8768K switches (Option 016)

From 11713D/E (Option 001)				To 8766K, 8767K & 8768K (Option 016)		
Front panel pushbutton		Interface cable		8766K	8767K	8768K
Attenuator X	LED	Viking connector pin number	10-pin DIP pin number	RF path	RF path	RF path
–	–	1 (VCC)	10	–	–	–
1	OFF	5	1	Bypass 1	Bypass 3	Bypass 4
	ON	6	2	1 to C closed	3 to C closed	4 to C closed
2	OFF	7	5	Bypass 2	Bypass 1	Bypass 2
	ON	8	8	2 to C closed	1 to C closed	2 to C closed
3	OFF	9	4	–	Bypass 2	Bypass 3
	ON	10	9	–	2 to C closed	3 to C closed
4	OFF	11	6	–	–	Bypass 1
	ON	12	7	–	–	1 to C closed

Table J-2: Configuration of 11713D/E (Option 101) to 8766K, 8767K & 8768K switches (Option 060)

From 11713D/E (Option 101)				To 8766K, 8767K & 8768K (Option 060)		
Front panel pushbutton		Interface cable		8766K	8767K	8768K
Attenuator X	LED	Viking connector pin number	Viking connector pin number	RF path	RF path	RF path
–	–	1 (VCC)	1	–	–	–
1	OFF	5	5	Bypass 1	Bypass 3	Bypass 4
	ON	6	6	1 to C closed	3 to C closed	4 to C closed
2	OFF	7	7	Bypass 2	Bypass 1	Bypass 2
	ON	8	8	2 to C closed	1 to C closed	2 to C closed
3	OFF	9	9	–	Bypass 2	Bypass 3
	ON	10	10	–	2 to C closed	3 to C closed
4	OFF	11	11	–	–	Bypass 1
	ON	12	12	–	–	1 to C closed

Note 1: Each table below illustrates the configuration of one switch to the 11713D/E.

Note 2: With assumption that initial state of switch's RF path is thru.

Note 3: One additional switch can be driven by Attenuator Y (front panel pushbuttons 5, 6, 7 & 8) using the same configuration as Attenuator X. Use S0 for Attenuator Y and S9 for Attenuator X.

Table K: Configuration of 11713D/E (Option 101) to 8769K SP6T switch (Option 060)

From 11713D/E (Option 101)				To 8769K (Option 060)
Front panel pushbutton		Interface cable		
Attenuator X	LED	Viking connector pin number	Viking connector pin number	RF path
–	–	1 (VCC)	1	–
S9	OFF	4	4	Bypass 5
	ON	3	3	5 to C closed
1	OFF	5	5	Bypass 4
	ON	6	6	4 to C closed
2	OFF	7	7	Bypass 2
	ON	8	8	2 to C closed
3	OFF	9	9	Bypass 3
	ON	10	10	3 to C closed
4	OFF	11	11	Bypass 1
	ON	12	12	1 to C closed

Table L: Configuration of 11713D/E (Option 001) to 8767M & 8768M switches

From 11713D/E (Option 001)				To 8767M and 8768M	
Front panel pushbutton		Interface cable			
Attenuator X	LED	Viking connector pin number	10-pin DIP pin number	RF path	RF path
–	–	1 (VCC)	10	–	–
1	OFF	5	1	Bypass 3	Bypass 4
	ON	6	2	3 to C closed	4 to C closed
2	OFF	7	5	Bypass 1	Bypass 2
	ON	8	8	1 to C closed	2 to C closed
3	OFF	9	4	Bypass 2	Bypass 3
	ON	10	9	2 to C closed	3 to C closed
4	OFF	11	6	–	Bypass 1
	ON	12	7	–	1 to C closed

Table M: Configuration of 11713D/E (Option 701) to 8769M SP6T switches

From 11713D/E (Option 701)				To 8769M
Front panel pushbutton		Interface cable		
Attenuator X	LED	Viking connector pin number	14-pin DIP pin number	RF path
–	–	1 (VCC)	12	–
S9	OFF	4	14	Bypass 5
	ON	3	13	5 to C closed
1	OFF	5	3	Bypass 4
	ON	6	4	4 to C closed
2	OFF	7	7	Bypass 2
	ON	8	10	2 to C closed
3	OFF	9	6	Bypass 3
	ON	10	11	3 to C closed
4	OFF	11	8	Bypass 1
	ON	12	9	1 to C closed

Note 1: Each table below illustrates the configuration of four switches to the 11713D/E.

Note 2: For standard/non-TTL drive only.

Note 3: Four additional switches can be driven by Attenuator Y (front panel pushbuttons 5, 6, 7 & 8) using the same configuration as Attenuator X.

Note 4: Do not drive using S9 or S0 outputs from either the banana plug outputs, or from pins 3 or 4 within the Attenuator X and Y Viking sockets, both located on the rear panel of the 11713D/E

Table N-1: Configuration of 11713D/E (Option 201) to L7222C & 87222C/D/E/R DPDT switches (Option 100)

From 11713D/E (Option 201)				To L7222C & 87222C/D/E/R (Option 100)		
Front panel pushbutton		Interface cable				
Attenuator X	LED	Viking connector pin number	Bare wire color	Solder terminal number	RF path	Device under test (DUT)
–	–	1 (VCC)	Red	1	–	VCC for all 4 DUTs
–	–	2 (GND)	White/Brown	9	–	GND for all 4 DUTs
1	OFF	5	Violet	3	1 to 2 closed, 3 to 4 closed	DUT 1
	ON	6	Yellow	5	1 to 4 closed, 2 to 3 closed	
2	OFF	7	Black	3	1 to 2 closed, 3 to 4 closed	DUT 2
	ON	8	Green	5	1 to 4 closed, 2 to 3 closed	
3	OFF	9	Orange	3	1 to 2 closed, 3 to 4 closed	DUT 3
	ON	10	Blue	5	1 to 4 closed, 2 to 3 closed	
4	OFF	11	Brown	3	1 to 2 closed, 3 to 4 closed	DUT 4
	ON	12	White	5	1 to 4 closed, 2 to 3 closed	

Table N-2: Configuration of 11713D/E (Option 801) to L7222C & 87222C/D/E/R DPDT switches (Option 161)

From 11713D/E (Option 801)				To L7222C & 87222C/D/E/R (Option 161)	
Front panel pushbutton		Interface cable			
Attenuator X	LED	Viking connector pin number	10-pin DIP pin number	RF path	Device under test (DUT)
–	–	1 (VCC)	1	–	VCC for all 4 DUTs
–	–	2 (GND)	9	–	GND for all 4 DUTs
1	OFF	5	3	1 to 2 closed, 3 to 4 closed	DUT 1
	ON	6	5	1 to 4 closed, 2 to 3 closed	
2	OFF	7	3	1 to 2 closed, 3 to 4 closed	DUT 2
	ON	8	5	1 to 4 closed, 2 to 3 closed	
3	OFF	9	3	1 to 2 closed, 3 to 4 closed	DUT 3
	ON	10	5	1 to 4 closed, 2 to 3 closed	
4	OFF	11	3	1 to 2 closed, 3 to 4 closed	DUT 4
	ON	12	5	1 to 4 closed, 2 to 3 closed	

Note 1: Each table below illustrates the configuration of five switches to the 11713D/E.

Note 2: For standard/non-TTL drive only.

Note 3: Five additional switches can be driven by Attenuator Y (front panel pushbuttons 5, 6, 7, 8 & 0) using the same configuration as Attenuator X.

Table O-1: Configuration of 11713D/E (Option 201) to N1810U/UL SPDT switch (Option 202)

From 11713D/E (Option 201)				To N1810U/UL(Option 202)		
Front panel pushbutton		Interface cable				
Attenuator X	LED	Viking connector pin number	Bare wire color	Solder terminal number	RF path	Device under test (DUT)
–	–	1 (VCC)	Red	+V	–	VCC for all 5 DUTs
–	–	2 (GND)	White/Brown	GND	–	GND for all 5 DUTs
1	OFF	5	Violet	A	1 to C closed, 2 open	DUT 1
	ON	6	Yellow	B	2 to C closed, 1 open	
2	OFF	7	Black	A	1 to C closed, 2 open	DUT 2
	ON	8	Green	B	2 to C closed, 1 open	
3	OFF	9	Orange	A	1 to C closed, 2 open	DUT 3
	ON	10	Blue	B	2 to C closed, 1 open	
4	OFF	11	Brown	A	1 to C closed, 2 open	DUT 4
	ON	12	White	B	2 to C closed, 1 open	
9	OFF	4	Gray	A	1 to C closed, 2 open	DUT 5
	ON	3	White/Red	B	2 to C closed, 1 open	

Table O-2: Configuration of 11713D/E (Option 501) to N1810U/UL SPDT switch (Option 201)

From 11713D/E (Option 501)				To N1810U/UL (Option 201)	
Front panel pushbutton		Interface cable			
Attenuator X	LED	Viking connector pin number/banana jack (rear panel)	9-Pin Dsub pin number	RF path	Device under test (DUT)
–	–	1 (VCC)/VDC COM	5	–	VCC for all 5 DUTs
–	–	2 (GND)/GND	1	–	GND for all 5 DUTs
1	OFF	5	4	1 to C closed, 2 open	DUT 1
	ON	6	3	2 to C closed, 1 open	
2	OFF	7	4	1 to C closed, 2 open	DUT 2
	ON	8	3	2 to C closed, 1 open	
3	OFF	9	4	1 to C closed, 2 open	DUT 3
	ON	10	3	2 to C closed, 1 open	
4	OFF	11	4	1 to C closed, 2 open	DUT 4
	ON	12	3	2 to C closed, 1 open	
9	OFF	S9-B	4	1 to C closed, 2 open	DUT 5
	ON	S9-A	3	2 to C closed, 1 open	

Note 1: Each table below illustrates the configuration of five switches to the 11713D/E.

Note 2: For standard/non-TTL drive only.

Note 3: Five additional switches can be driven by Attenuator Y (front panel pushbuttons 5, 6, 7, 8 & 0) using the same configuration as Attenuator X.

Table O-3: Configuration of 11713D/E (Option 201) to N1810T/TL SPDT (Option 202)

From 11713D/E (Option 201)				To N1810T/TL (Option 202)		
Front panel pushbutton		Interface cable				
Attenuator X	LED	Viking connector pin number	Bare wire color	Solder terminal number	RF path	Device under test (DUT)
–	–	1 (VCC)	Red	+V	–	VCC for all 5 DUTs
–	–	2 (GND)	White/Brown	GND	–	GND for all 5 DUTs
1	OFF	5	Violet	A	1 to C closed, 2 terminated	DUT 1
	ON	6	Yellow	B	2 to C closed, 1 terminated	
2	OFF	7	Black	A	1 to C closed, 2 terminated	DUT 2
	ON	8	Green	B	2 to C closed, 1 terminated	
3	OFF	9	Orange	A	1 to C closed, 2 terminated	DUT 3
	ON	10	Blue	B	2 to C closed, 1 terminated	
4	OFF	11	Brown	A	1 to C closed, 2 terminated	DUT 4
	ON	12	White	B	2 to C closed, 1 terminated	
9	OFF	4	Gray	A	1 to C closed, 2 terminated	DUT 5
	ON	3	White/Red	B	2 to C closed, 2 terminated	

Table O-4: Configuration of 11713D/E (Option 501) to N1810T/TL SPDT switch (Option 201)

From 11713D/E (Option 501)				To N1810T/TL (Option 201)	
Front panel pushbutton		Interface cable			
Attenuator X	LED	Viking connector pin number/ banana jack (rear panel)	9-pin Dsub pin number	RF path	Device under test (DUT)
–	–	1 (VCC)/VDC COM	5	–	VCC for all 5 DUTs
–	–	2 (GND)/GND	1	–	GND for all 5 DUTs
1	OFF	5	4	1 to C closed, 2 terminated	DUT 1
	ON	6	3	2 to C closed, 1 terminated	
2	OFF	7	4	1 to C closed, 2 terminated	DUT 2
	ON	8	3	2 to C closed, 1 terminated	
3	OFF	9	4	1 to C closed, 2 terminated	DUT 3
	ON	10	3	2 to C closed, 1 terminated	
4	OFF	11	4	1 to C closed, 2 terminated	DUT 4
	ON	12	3	2 to C closed, 1 terminated	
9	OFF	S9-B	4	1 to C closed, 2 terminated	DUT 5
	ON	S9-A	3	2 to C closed, 2 terminated	

Note 1: Each table below illustrates the configuration of two switches to the 11713D/E.

Note 2: For Option 401 (TTL drive) only.

Note 3: Two additional switches can be driven by Attenuator Y (front panel pushbuttons 5, 6, 7 & 8) using the same configuration as Attenuator X.

Table O-5: Configuration of 11713D/E (Option 201) to N1810U/UL SPDT (Option 202/401)

From 11713D/E (Option 201)				To N1810U/UL (Option 202/401)		
Front panel pushbutton		Interface Cable				
Attenuator X	LED	Viking connector pin number	Bare wire color	Solder terminal number	RF path	Device under test (DUT)
–	–	1 (VCC)	Red	+V	–	VCC for all 2 DUTs
–	–	2 (GND)	White/Brown	GND	–	GND for all 2 DUTs
1	OFF	5	Violet	A	1 to C closed, 2 open	DUT1
2	ON	7	Black	B		
1	ON	5	Violet	A	2 to C closed, 1 open	
2	OFF	7	Black	B		
3	OFF	9	Orange	A	1 to C closed, 2 open	DUT2
4	ON	11	Brown	B		
3	ON	9	Orange	A	2 to C closed, 1 open	
4	OFF	11	Brown	B		

Table O-6: Configuration of 11713D/E (Option 502) to N1810U/UL SPDT switch (Option 201/401)

From 11713D/E (Option 502)				To N1810U/UL (Option 201/401)	
Front panel pushbutton		Interface Cable			
Attenuator X	LED	Viking connector pin number/ banana jack (rear panel)	9-pin Dsub pin number	RF path	Device under test (DUT)
–	–	1 (VCC)/VDC COM	5	–	VCC for all 2 DUTs
–	–	2 (GND)/GND	1	–	GND for all 2 DUTs
1	OFF	5	4	1 to C closed, 2 open	DUT1
2	ON	7	3		
1	ON	5	4	2 to C closed, 1 open	
2	OFF	7	3		
3	OFF	9	4	1 to C closed, 2 open	DUT2
4	ON	11	3		
3	ON	9	4	2 to C closed, 1 open	
4	OFF	11	3		

Note 1: Each table below illustrates the configuration of two switches to the 11713D/E.

Note 2: For Option 401 (TTL drive) only.

Note 3: Two additional switches can be driven by Attenuator Y (front panel pushbuttons 5, 6, 7 & 8) using the same configuration as Attenuator X.

Table O-7: Configuration of 11713D/E (Option 201) to N1810T/TL SPDT switch (Option 202/401)

From 11713D/E (Option 201)				To N1810T/TL (Option 202/401)		
Front panel pushbutton		Interface cable				
Attenuator X	LED	Viking connector pin number	Bare wire color	Solder terminal number	RF path	Device under test (DUT)
–	–	1 (VCC)	Red	+V	–	VCC for all 2 DUTs
–	–	2 (GND)	White/Brown	GND	–	GND for all 2 DUTs
1	OFF	5	Violet	A	1 to C closed, 2 terminated	DUT1
2	ON	7	Black	B		
1	ON	5	Violet	A	2 to C closed, 1 terminated	
2	OFF	7	Black	B		
3	OFF	9	Orange	A	1 to C closed, 2 terminated	DUT2
4	ON	11	Brown	B		
3	ON	9	Orange	A	2 to C closed, 1 terminated	
4	OFF	11	Brown	B		

Table O-8: Configuration of 11713D/E (Option 502) to N1810T/TL SPDT switch (Option 201/401)

From 11713D/E (Option 502)				To N1810T/TL (Option 201/401)	
Front panel pushbutton		Interface cable			
Attenuator X	LED	Viking connector pin number/ banana jack (rear panel)	9-pin Dsub pin number	RF path	Device under test (DUT)
–	–	1 (VCC)/VDC COM	5	–	VCC for all 2 DUTs
–	–	2 (GND)/GND	1	–	GND for all 2 DUTs
1	OFF	5	4	1 to C closed, 2 terminated	DUT1
2	ON	7	3		
1	ON	5	4	2 to C closed, 1 terminated	
2	OFF	7	3		
3	OFF	9	4	1 to C closed, 2 terminated	DUT2
4	ON	11	3		
3	ON	9	4	2 to C closed, 1 terminated	
4	OFF	11	3		

Note 1: Each table below illustrates configuration of five switches to 11713D/E.

Note 2: For standard/non TTL drive only.

Note 3: Five additional switches can be driven by Attenuator Y (front panel pushbuttons 5, 6, 7, 8 & 0) using the same configuration as Attenuator X.

Table O-9: Configuration of 11713D/E (Option 201) to N1812U/UL bypass switch (Option 202)

From 11713D/E (Option 201)				To N1812U/UL (Option 202)		
Front panel pushbutton		Interface cable				
Attenuator X	LED	Viking connector pin number	Bare wire color	Solder terminal number	RF path	Device under test (DUT)
–	–	1 (VCC)	Red	+V	–	VCC for all 5 DUTs
–	–	2 (GND)	White/Brown	GND	–	GND for all 5 DUTs
1	OFF	5	Violet	A	1 to open, 2 to 3, 4 to 5	DUT 1
	ON	6	Yellow	B	1 to 2, 3 to 4, 5 to open	
2	OFF	7	Black	A	1 to open, 2 to 3, 4 to 5	DUT 2
	ON	8	Green	B	1 to 2, 3 to 4, 5 to open	
3	OFF	9	Orange	A	1 to open, 2 to 3, 4 to 5	DUT 3
	ON	10	Blue	B	1 to 2, 3 to 4, 5 to open	
4	OFF	11	Brown	A	1 to open, 2 to 3, 4 to 5	DUT 4
	ON	12	White	B	1 to 2, 3 to 4, 5 to open	
9	OFF	4	Gray	A	1 to open, 2 to 3, 4 to 5	DUT 5
	ON	3	White/Red	B	1 to 2, 3 to 4, 5 to open	

Table O-10: Configuration of 11713D/E (Option 501) to N1812U/UL bypass switch (Option 201)

From 11713D/E (Option 501)				To N1812U/UL (Option 201)	
Front panel pushbutton		Interface cable			
Attenuator X	LED	Viking connector pin number/ banana jack (rear panel)	9-pin Dsub pin number	RF path	Device under test (DUT)
–	–	1 (VCC)/VDC COM	5	–	VCC for all 5 DUTs
–	–	2 (GND)/GND	1	–	GND for all 5 DUTs
1	OFF	5	4	1 to open, 2 to 3, 4 to 5	DUT 1
	ON	6	3	1 to 2, 3 to 4, 5 to open	
2	OFF	7	4	1 to open, 2 to 3, 4 to 5	DUT 2
	ON	8	3	1 to 2, 3 to 4, 5 to open	
3	OFF	9	4	1 to open, 2 to 3, 4 to 5	DUT 3
	ON	10	3	1 to 2, 3 to 4, 5 to open	
4	OFF	11	4	1 to open, 2 to 3, 4 to 5	DUT 4
	ON	12	3	1 to 2, 3 to 4, 5 to open	
9	OFF	S9-B	4	1 to open, 2 to 3, 4 to 5	DUT 5
	ON	S9-A	3	1 to 2, 3 to 4, 5 to open	

Note 1: Each table below illustrates configuration of five switches to 11713D/E.

Note 2: For standard/non TTL drive only.

Note 3: Five additional switches can be driven by Attenuator Y (front panel pushbuttons 5, 6, 7, 8 & 0) using the same configuration as Attenuator X.

Table O-11: Configuration of 11713D/E (Option 201) to N1811T/TL bypass switch (Option 202)

From 11713D/E (Option 201)				To N1811T/TL (Option 202)		
Front panel pushbutton		Interface cable				
Attenuator X	LED	Viking connector pin number	Bare wire color	Solder terminal number	RF path	Device under test (DUT)
–	–	1 (VCC)	Red	+V	–	VCC for all 5 DUTs
–	–	2 (GND)	White/Brown	GND	–	GND for all 5 DUTs
1	OFF	5	Violet	A	1 to 2, 3 to 4	DUT 1
	ON	6	Yellow	B	1 terminated, 2 to 3, 4 to open	
2	OFF	7	Black	A	1 to 2, 3 to 4	DUT 2
	ON	8	Green	B	1 terminated, 2 to 3, 4 to open	
3	OFF	9	Orange	A	1 to 2, 3 to 4	DUT 3
	ON	10	Blue	B	1 terminated, 2 to 3, 4 to open	
4	OFF	11	Brown	A	1 to 2, 3 to 4	DUT 4
	ON	12	White	B	1 terminated, 2 to 3, 4 to open	
9	OFF	4	Gray	A	1 to 2, 3 to 4	DUT 5
	ON	3	White/Red	B	1 terminated, 2 to 3, 4 to open	

Table O-12: Configuration of 11713D/E (Option 501) to N1811T/TL bypass switch (Option 201)

From 11713D/E (Option 501)				To N1811T/TL (Option 201)	
Front panel pushbutton		Interface cable			
Attenuator X	LED	Viking connector pin number/ banana jack (rear panel)	9-pin Dsub pin number	RF path	Device under test (DUT)
–	–	1 (VCC)/VDC COM	5	–	VCC for all 5 DUTs
–	–	2 (GND)/GND	1	–	GND for all 5 DUTs
1	OFF	5	4	1 to 2, 3 to 4	DUT 1
	ON	6	3	1 terminated, 2 to 3, 4 to open	
2	OFF	7	4	1 to 2, 3 to 4	DUT 2
	ON	8	3	1 terminated, 2 to 3, 4 to open	
3	OFF	9	4	1 to 2, 3 to 4	DUT 3
	ON	10	3	1 terminated, 2 to 3, 4 to open	
4	OFF	11	4	1 to 2, 3 to 4	DUT 4
	ON	12	3	1 terminated, 2 to 3, 4 to open	
9	OFF	S9-B	4	1 to 2, 3 to 4	DUT 5
	ON	S9-A	3	1 terminated, 2 to 3, 4 to open	

Note 1: Each table below illustrates configuration of two switches to 11713D/E.

Note 2: For Option 401 (TTL drive) only.

Note 3: Two additional switches can be driven by Attenuator Y (front panel pushbuttons 5, 6, 7 & 8) using the same configuration as Attenuator X.

Table O-13: Configuration of 11713D/E (Option 201) to N1812U/UL bypass switch (Option 202/401)

From 11713D/E (Option 201)				To N1812U/UL (Option 202/401)		
Front panel pushbutton		Interface cable				
Attenuator X	LED	Viking connector pin number	Bare wire color	Solder terminal number	RF path	Device under test (DUT)
–	–	1 (VCC)	Red	+V	–	VCC for all 2 DUTs
–	–	2 (GND)	White/Brown	GND	–	GND for all 2 DUTs
1	OFF	5	Violet	A	1 to open, 2 to 3, 4 to 5	DUT1
2	ON	7	Black	B		
1	ON	5	Violet	A	1 to 2, 3 to 4, 5 to open	
2	OFF	7	Black	B		
3	OFF	9	Orange	A	1 to open, 2 to 3, 4 to 5	DUT2
4	ON	11	Brown	B		
3	ON	9	Orange	A	1 to 2, 3 to 4, 5 to open	
4	OFF	11	Brown	B		

Table O-14: Configuration of 11713D/E (Option 502) to N1812U/UL bypass switch (Option 201/401)

From 11713D/E (Option 502)				To N1812U/UL (Option 201/401)	
Front panel pushbutton		Interface cable			
Attenuator X	LED	Viking connector pin number/ banana jack (rear panel)	9-pin Dsub pin number	RF path	Device under test (DUT)
–	–	1 (VCC)/VDC COM	5	–	VCC for all 2 DUTs
–	–	2 (GND)/GND	1	–	GND for all 2 DUTs
1	OFF	5	4	1 to open, 2 to 3, 4 to 5	DUT1
2	ON	7	3		
1	ON	5	4	1 to 2, 3 to 4, 5 to open	
2	OFF	7	3		
3	OFF	9	4	1 to open, 2 to 3, 4 to 5	DUT2
4	ON	11	3		
3	ON	9	4	1 to 2, 3 to 4, 5 to open	
4	OFF	11	3		

Note 1: Each table below illustrates configuration of two switches to 11713D/E.

Note 2: For Option 401 (TTL drive) only.

Note 3: Two additional switches can be driven by Attenuator Y (front panel pushbuttons 5, 6, 7 & 8) using the same configuration as Attenuator X.

Table O-15: Configuration of 11713D/E (Option 201) to N1811T/TL bypass switch (Option 202/401)

From 11713D/E (Option 201)				To N1811T/TL (Option 202/401)		
Front panel pushbutton		Interface cable				
Attenuator X	LED	Viking connector pin number	Bare wire color	Solder terminal number	RF path	Device under test (DUT)
–	–	1 (VCC)	Red	+V	–	VCC for all 2 DUTs
–	–	2 (GND)	White/Brown	GND	–	GND for all 2 DUTs
1	OFF	5	Violet	A	1 to 2, 3 to 4	DUT1
2	ON	7	Black	B		
1	ON	5	Violet	A	1 terminated, 2 to 3, 4 to open	
2	OFF	7	Black	B		
3	OFF	9	Orange	A	1 to 2, 3 to 4	DUT2
4	ON	11	Brown	B		
3	ON	9	Orange	A	1 terminated, 2 to 3, 4 to open	
4	OFF	11	Brown	B		

Table O-16: Configuration of 11713D/E (Option 502) to N1811T/TL bypass switch (Option 201/401)

From 11713D/E (Option 502)				To N1811T/TL (Option 201/401)	
Front panel pushbutton		Interface cable			
Attenuator X	LED	Viking connector pin number/ banana jack (rear panel)	9-pin Dsub pin number	RF path	Device under test (DUT)
–	–	1 (VCC)/VDC COM	5	–	VCC for all 2 DUTs
–	–	2 (GND)/GND	1	–	GND for all 2 DUTs
1	OFF	5	4	1 to 2, 3 to 4	DUT1
2	ON	7	3		
1	ON	5	4	1 terminated, 2 to 3, 4 to open	
2	OFF	7	3		
3	OFF	9	4	1 to 2, 3 to 4	DUT2
4	ON	11	3		
3	ON	9	4	1 terminated, 2 to 3, 4 to open	
4	OFF	11	3		

Note 1: Each table below illustrates the configuration of one switch to the 11713D/E.

Note 2: Ground pin 3 or 13 to open all paths. Do not close any path and ground pin 3 or 13 simultaneously as this makes the switch buzz. *

Note 3: 24-pin DIP connector with pin numbers 6, 8, 10, 12, 16, 18, 20 and 22 provides indicator function.

Note 4: Applies to both Option 200 (standard/non-TTL drive) and Option 300 (TTL drive).

Table P-1: Configuration of 11713D/E (Option 106) to U7108A/B/C SP8T switches (Option 200/300)

From 11713D/E (Option 106)				To U7108A/B/C SP8T Switches (Option 200/300)			
Front panel push button			Interface cable				SP8T connection description
Attenuator X	Attenuator Y	Attenuator X	Viking cable		24-pin connector pin number		
Bank 1	Bank 1	Bank 2	LED	ATTEN X		ATTEN Y	
				Pin number			
			-	1	-	1	Vcc
			-	2	-	23	GND
9			ON	3	-	20	Ind 9
			OFF	4	-	19	Path 9
1			OFF	5	-	3	Open all
2			OFF	7	-	5	Path 2
			ON	8	-	6	Ind 2
3			OFF	9	-	7	Path 3
			ON	10	-	8	Ind 3
4			OFF	11	-	9	Path 4
			ON	12	-	10	Ind 4
	0		ON		3	22	Ind 10
			OFF	-	4	21	Path 10
	5		OFF	-	5	11	Path 5
			ON	-	6	12	Ind 5
	6		OFF	-	7	13	Open all
	7		OFF	-	9	15	Path 7
			ON	-	10	16	Ind 7
	8		OFF	-	11	17	Path 8
			ON	-	12	18	Ind 8

Note 1: Each table below illustrates the configuration of one switch to the 11713D/E.

Note 2: Ground pin 3 or 13 to open all paths. Do not close any path and ground pin 3 or 13 simultaneously as this makes the switch buzz. *

Note 3: Solder terminal connector with pin numbers 6, 8, 10, 12, 16, 18, 20 and 22 provides indicator function.

Note 4: Applies to both Option 400 (standard/non-TTL drive) and Option 500 (TTL drive).

Table P-2: Configuration of 11713D/E (Option 201) to U7108A/B/C SP8T switches (Option 400/500)

From 11713D/E (Option 201)				To U7108A/B/C SP8T Switches (Option 400/500)		
Front panel push button		Interface cable		Solder terminal number	SP8T connection description	
Attenuator X Bank 1	Attenuator Y Bank 1	LED	Viking connector pin number Bare wire color			
		-	Cable 1-1 RED	1	Vcc	
		-	Cable 1-2 WHT/BRN	23	GND	
9		ON	Cable 1-3 GREY	20	Ind 9	
		OFF	Cable 1-4 WHT/RED	19	Path 9	
1		OFF	Cable 1-5 PURPLE	3	Open all	
2		OFF	Cable 1-7 BLACK	5	Path 2	
		ON	Cable 1-8 GREEN	6	Ind 2	
3		OFF	Cable 1-9 ORANGE	7	Path 3	
		ON	Cable 1-10 BLUE	8	Ind 3	
4		OFF	Cable 1-11 BROWN	9	Path 4	
		ON	Cable 1-12 WHITE	10	Ind 4	
	0	ON	Cable 2-3 GREY	22	Ind 10	
		OFF	Cable 2-4 WHT/RED	21	Path 10	
	5	OFF	Cable 2-5 PURPLE	11	Path 5	
		ON	Cable 2-6 YELLOW	12	Ind 5	
	6	OFF	Cable 2-7 BLACK	13	Open all	
	7	OFF	Cable 2-9 ORANGE	15	Path 7	
		ON	Cable 2-10 BLUE	16	Ind 7	
	8	OFF	Cable 2-11 BROWN	17	Path 8	
		ON	Cable 2-12 WHITE	18	Ind 8	

Note 1: Each table below illustrates the configuration of one switch to the 11713D/E.

Note 2: Ground pin 24 to open all paths. Do not close any path and ground pin 24 simultaneously as this makes the switch buzz. *

Note 3: 24-pin DIP connector with pin numbers 4, 6, 8, 10, 12, 14, 16, 18, 20 and 22 provides indicator function.

Note 4: Applies to both Option 200 (standard/non-TTL drive) and Option 300 (TTL drive).

Table P-3: Configuration of 11713D/E (Option 107) to U7110A/B/C SP10T switches (Option 200/300)

From 11713D/E (Option 107)							To U7110A/B/C SP10T Switches (Option 200/300)	
Front panel push button				Interface cable			24-pin connector pin number	SP10T connection description
Attenuator X	Attenuator Y	Attenuator X	LED	Viking cable				
Bank 1	Bank 1	Bank 2		ATTEN X (B1)	ATTEN Y	ATTEN X (B2)		
						Pin number		
			-	1	-	-	1	Vcc
			-	2	-	-	23	GND
9			ON	3	-	-	20	Ind 9
			OFF	4	-	-	19	Path 9
1			OFF	5	-	-	3	Path 1
			ON	6	-	-	4	Ind 1
2			OFF	7	-	-	5	Path 2
			ON	8	-	-	6	Ind 2
3			OFF	9	-	-	7	Path 3
			ON	10	-	-	8	Ind 3
4			OFF	11	-	-	9	Path 4
			ON	12	-	-	10	Ind 4
	0		ON	-	3	-	22	Ind 10
			OFF	-	4	-	21	Path 10
	5		OFF	-	5	-	11	Path 5
			ON	-	6	-	12	Ind 5
	6		OFF	-	7	-	13	Path 6
			ON	-	8	-	14	Ind 6
	7		OFF	-	9	-	15	Path 7
			ON	-	10	-	16	Ind 7
	8		OFF	-	11	-	17	Path 8
			ON	-	12	-	18	Ind 8
		9	OFF	-	-	4	24	Open all

Note 1: Each table below illustrates the configuration of one switch to the 11713D/E.

Note 2: Ground pin 24 to open all paths. Do not close any path and ground pin 24 simultaneously as this makes the switch buzz. *

Note 3: Solder terminal connector with pin numbers 4, 6, 8, 10, 12, 14, 16, 18, 20 and 22 provides indicator function.

Note 4: Applies to both Option 400 (standard/non-TTL drive) and Option 500 (TTL drive).

Table P-4: Configuration of 11713D/E (Option 201) to U7110A/B/C SP10T switches (Option 400/500)

From 11713D/E (Option 201)						To U7110A/B/C SP10T Switches (Option 400/500)	
Front panel push button			Interface cable			Solder terminal number	SP10T connection description
Attenuator X	Attenuator Y	Attenuator X	LED	Viking connector pin number	Bare wire color		
Bank 1	Bank 1	Bank 2					
			-	Cable 1-1	RED	1	Vcc
			-	Cable 1-2	WHT/BRN	23	GND
9			ON	Cable 1-3	GREY	20	Ind 9
			OFF	Cable 1-4	WHT/RED	19	Path 9
1			OFF	Cable 1-5	PURPLE	3	Path 1
			ON	Cable 1-6	YELLOW	4	Ind 1
2			OFF	Cable 1-7	BLACK	5	Path 2
			ON	Cable 1-8	GREEN	6	Ind 2
3			OFF	Cable 1-9	ORANGE	7	Path 3
			ON	Cable 1-10	BLUE	8	Ind 3
4			OFF	Cable 1-11	BROWN	9	Path 4
			ON	Cable 1-12	WHITE	10	Ind 4
	0		ON	Cable 2-3	GREY	22	Ind 10
			OFF	Cable 2-4	WHT/RED	21	Path 10
	5		OFF	Cable 2-5	PURPLE	11	Path 5
			ON	Cable 2-6	YELLOW	12	Ind 5
	6		OFF	Cable 2-7	BLACK	13	Path 6
			ON	Cable 2-8	GREEN	14	Ind 6
	7		OFF	Cable 2-9	ORANGE	15	Path 7
			ON	Cable 2-10	BLUE	16	Ind 7
	8		OFF	Cable 2-11	BROWN	17	Path 8
			ON	Cable 2-12	WHITE	18	Ind 8
		9	OFF	Cable 3-4	WHT/RED	24	Open all

Configuration Information for Attenuators

Note 1: Each table below illustrates the configuration of one attenuator to the 11713D/E.

Note 2: One additional attenuator can be driven by Attenuator Y (front panel pushbuttons 5, 6, 7 & 8) using the same configuration as Attenuator X.

Note 3: To drive multiple sections of attenuator with Option 011 (5 V operating supply voltage) simultaneously, refer to respective attenuator data sheet for minimum voltage required (user defined terminal to be used), or add an interval delay for each section, refer to respective attenuator data sheet for switching speed.

Table Q-1: Configuration of 11713D/E (Option 001) to 8494G/H, 8495G/H, 8496G/H, 8495K & 8497K programmable attenuators (Option 016)

From 11713D/E (Option 001)				To attenuators (Option 016)				
Front panel pushbutton		Interface cable		8494G/H	8495G/H	8496G/H	8495K	8497K
Attenuator X	LED	Viking connector pin number	10-pin DIP pin number	Attenuation (dB)				
–	–	1 (VCC)	10	–	–	–	–	–
1	OFF	5	1	0	0	0	0	0
	ON	6	2	1	10	10	10	10
2	OFF	7	5	0	0	0	0	0
	ON	8	8	2	20	20	20	20
3	OFF	9	4	0	0	0	0	0
	ON	10	9	4	40	40	20	30
4	OFF	11	6	0	–	0	0	0
	ON	12	7	4	–	40	20	30

Table Q-2: Configuration of 11713D/E (Option 101) to 8494G/H, 8495G/H, 8496G/H, 8495K & 8497K programmable attenuators (Option 060)

From 11713D/E (Option 101)				To attenuators (Option 060)				
Front panel pushbutton		Interface cable		8494G/H	8495G/H	8496G/H	8495K	8497K
Attenuator X	LED	Viking connector pin number	Viking connector pin number	Attenuation (dB)				
–	–	1 (VCC)	1	–	–	–	–	–
1	OFF	5	5	0	0	0	0	0
	ON	6	6	1	10	10	10	10
2	OFF	7	7	0	0	0	0	0
	ON	8	8	2	20	20	20	20
3	OFF	9	9	0	0	0	0	0
	ON	10	10	4	40	40	20	30
4	OFF	11	11	0	–	0	0	0
	ON	12	12	4	–	40	20	30

Table R: Configuration of 11713D/E (Option 001) to 84904K/L/M, 84905M, 84906K/L, 84907K/L & 84908M programmable attenuators

From 11713D/E (Option 001)				To attenuators				
Front panel pushbutton		Interface cable		84904K/L/M	84905M	84906K/L	84907K/L	84908M
Attenuator X	LED	Viking connector pin number	10-pin DIP pin number	Attenuation (dB)				
-	-	1 (VCC)	10	-	-	-	-	-
1	OFF	5	1	0	0	0	0	0
	ON	6	2	1	10	10	10	5
2	OFF	7	5	0	0	0	0	0
	ON	8	8	2	20	20	20	10
3	OFF	9	4	0	0	0	0	0
	ON	10	9	4	30	30	40	20
4	OFF	11	6	0		0		0
	ON	12	7	4		30		30

Table S: Configuration of 11713D/E (Option 102) to P9400A/C PIN solid state transfer switches

11713D/E (Option 102)					
Interface cable Viking connector pin number	Cable				To P9400A/C (max 4 units)
	SW1	SW2	SW3	SW4	
	Bare wire color				Terminal
1	Red	Red	Red	Red	+5V
2	Yellow	Yellow	Yellow	Yellow	GND
3	-	-	-	-	-
4	Blue	Blue	Blue	Blue	-5V
5	Green	-	-	-	TTL
6	-	-	-	-	-
7	-	Green	-	-	TTL
8	-	-	-	-	-
9	-	-	Green	-	TTL
10	-	-	-	-	-
11	-	-	-	Green	TTL
12	-	-	-	-	-

Table T: Configuration of 11713D/E (Option 103) to P9402A/C PIN solid state SPDT switches

11713D/E (Option 103)			
Interface cable	Cable		To P9402A/C (max 2 units)
Viking connector pin number	SW1	SW2	
	Bare wire color		
1	Red	Red	+5V
2	White	White	GND
3	-	-	-
4	Blue	Blue	-5V
5	Green	-	CTRL 1
6	-	-	-
7	Orange	-	CTRL 2
8	-	-	-
9	-	Green	CTRL 1
10	-	-	-
11	-	Orange	CTRL 2
12	-	-	-

Table U: Configuration of 11713D/E (Option 104) to U9400A/C FET solid state transfer switches

11713D/E (Option 104)					
Interface cable	Cable				To U9400A/C (max 4 units)
Viking connector pin number	SW1	SW2	SW3	SW4	
1	VDC	VDC	VDC	VDC	VDC
2	GND	GND	GND	GND	GND
3	-	-	-	-	-
4	-	-	-	-	-
5	CTRL	-	-	-	CTRL
6	-	-	-	-	-
7	-	CTRL	-	-	CTRL
8	-	-	-	-	-
9	-	-	CTRL	-	CTRL
10	-	-	-	-	-
11	-	-	-	CTRL	CTRL
12	-	-	-	-	-

Table V: Configuration of 11713D/E (Option 105) to U9397A/C FET solid state SDPT switches

11713D/E (Option 105)					
Interface cable	Cable				To U9397A/C (max 4 units)
Viking connector pin number	SW1	SW2	SW3	SW4	
	Bare wire color				Terminal
1	Red	Red	Red	Red	VDC
2	Yellow	Yellow	Yellow	Yellow	GND
3	-	-	-	-	-
4	-	-	-	-	-
5	Black	-	-	-	CTRL
6	-	-	-	-	-
7	-	Black	-	-	CTRL
8	-	-	-	-	-
9	-	-	Black	-	CTRL
10	-	-	-	-	-
11	-	-	-	Black	CTRL
12	-	-	-	-	-

Table W: Configuration of 11713D/E (Option 201) to P9404A/C PIN solid state SP4T switches

11713D/E (Option 201)		
Interface cable	Bare wire color	To P9404A/C
Viking connector pin number		
1	RED	+5V
2	WHT/BRN	GND
3	GREY	-
4	WHT/RED	-5V
5	PURPLE	CTRL 1
6	YELLOW	-
7	BLACK	CTRL 2
8	GREEN	-
9	ORANGE	CTRL 3
10	BLUE	-
11	BROWN	CTRL 4
12	WHITE	-

Interface Cable Drawings

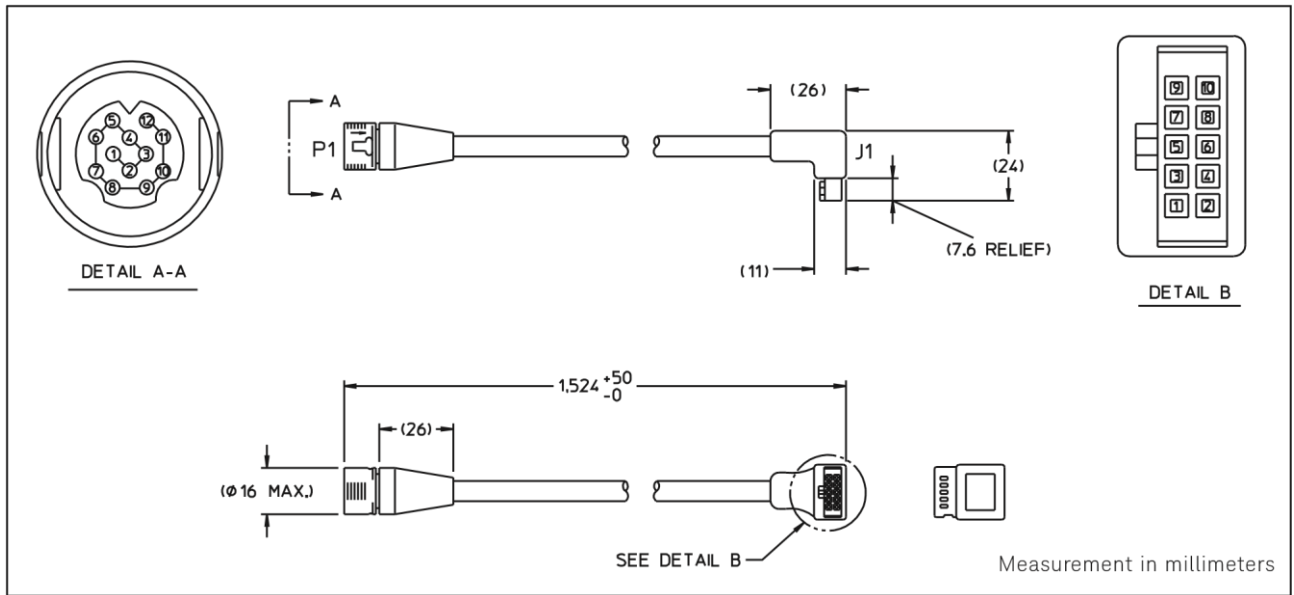

Figure 1. Option 001 Viking connector to 10-pin DIP connector

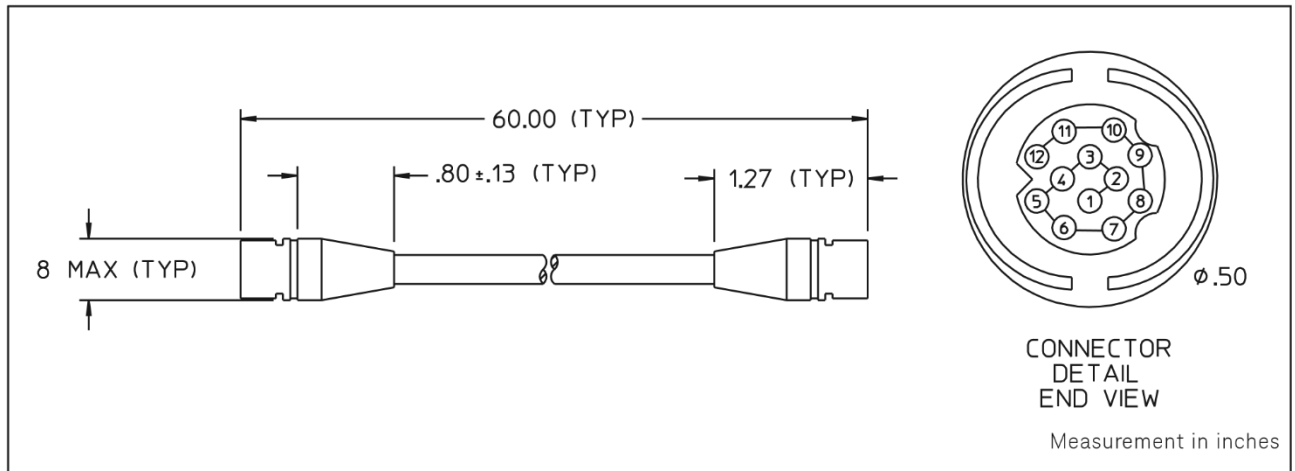

Figure 2. Option 201 Viking connector to 12-pin conductor cable, bare wire

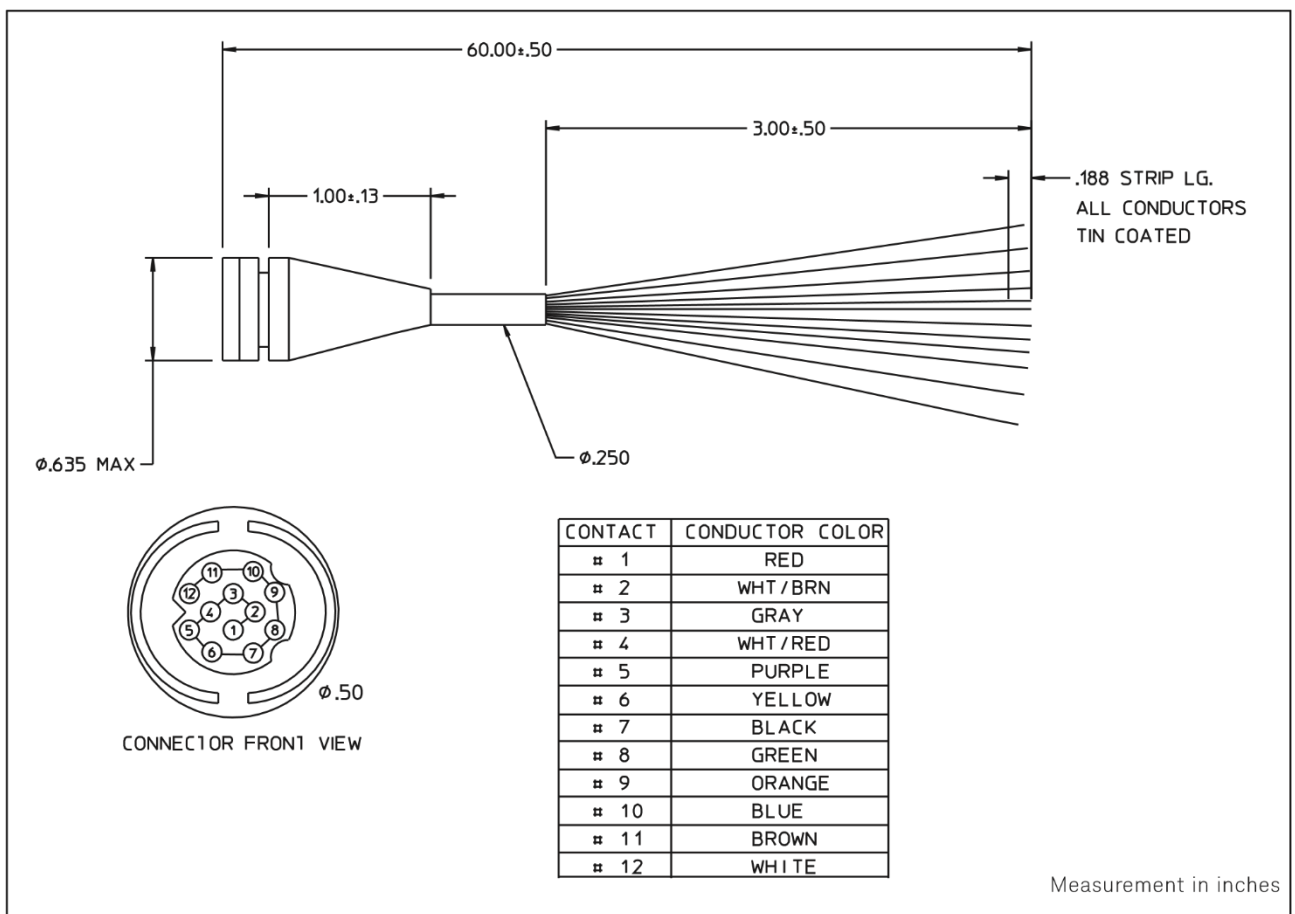

Figure 3. Option 201 Viking connector to 12-pin conductor cable, bare wire

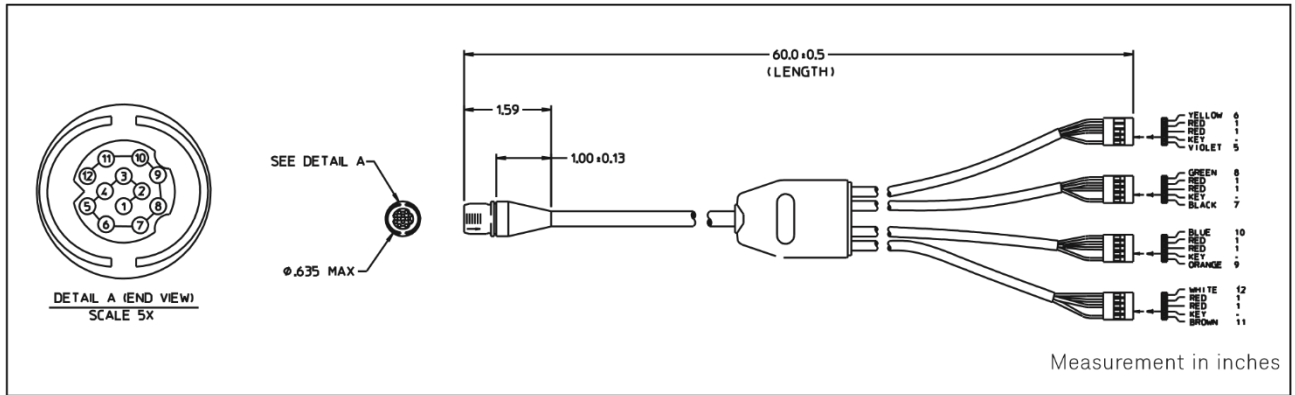

Figure 4. Option 301 Viking connector to ribbon cables

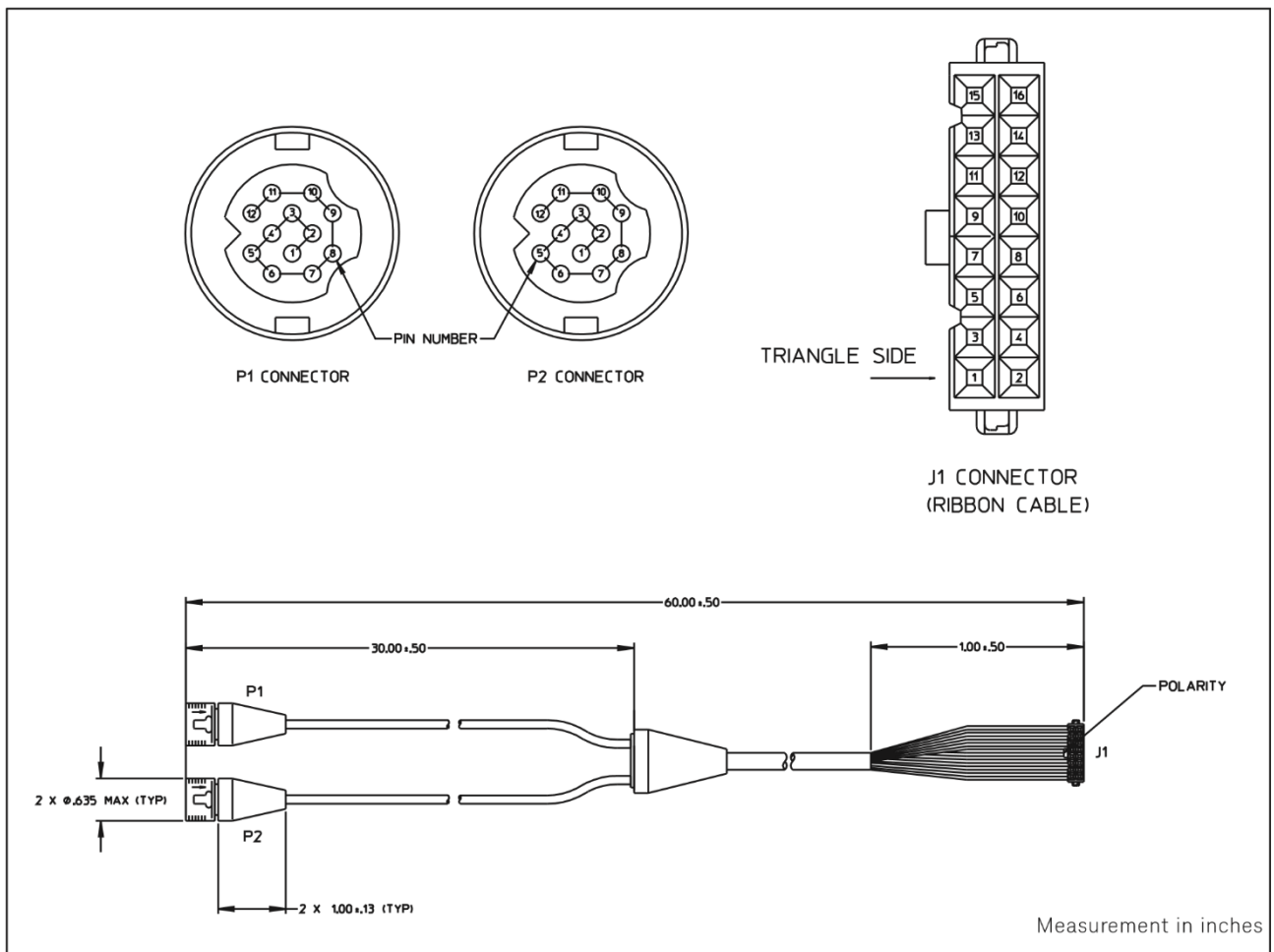

Figure 5. Option 401 Dual-viking connector 16-pin DIP

connector

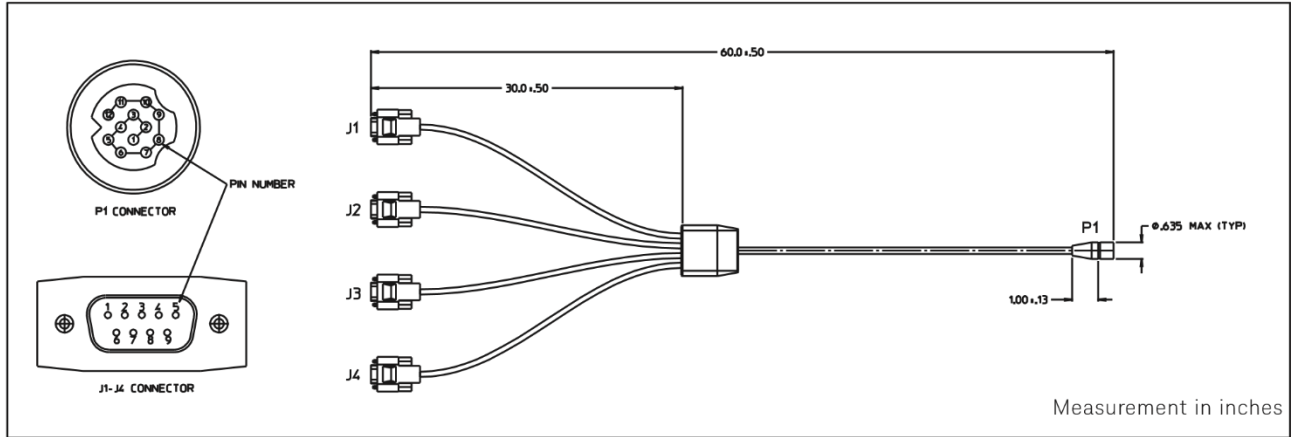

Figure 6. Option 501 Viking connector to (4) 9-pin Dsub connectors

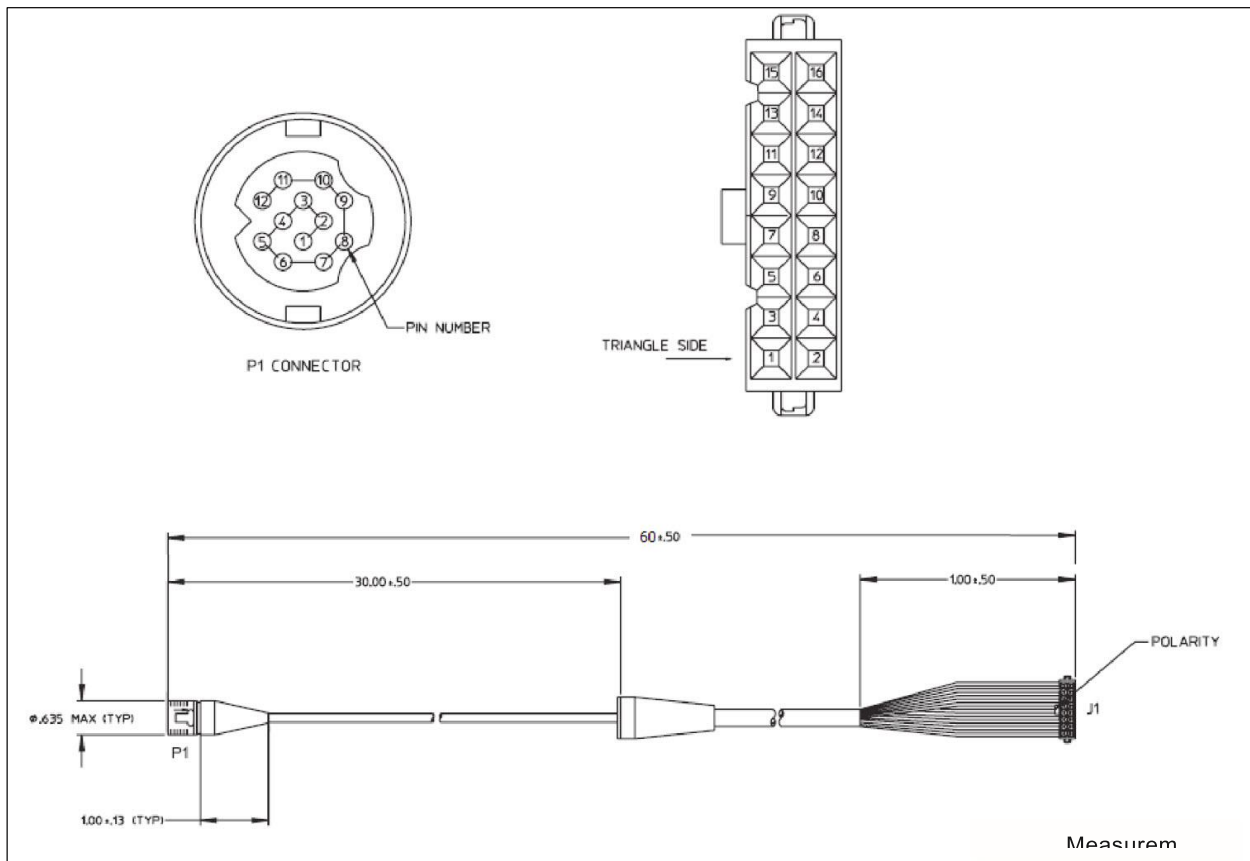

Figure 7. Option 601 Viking connector to 16-pin DIP connector

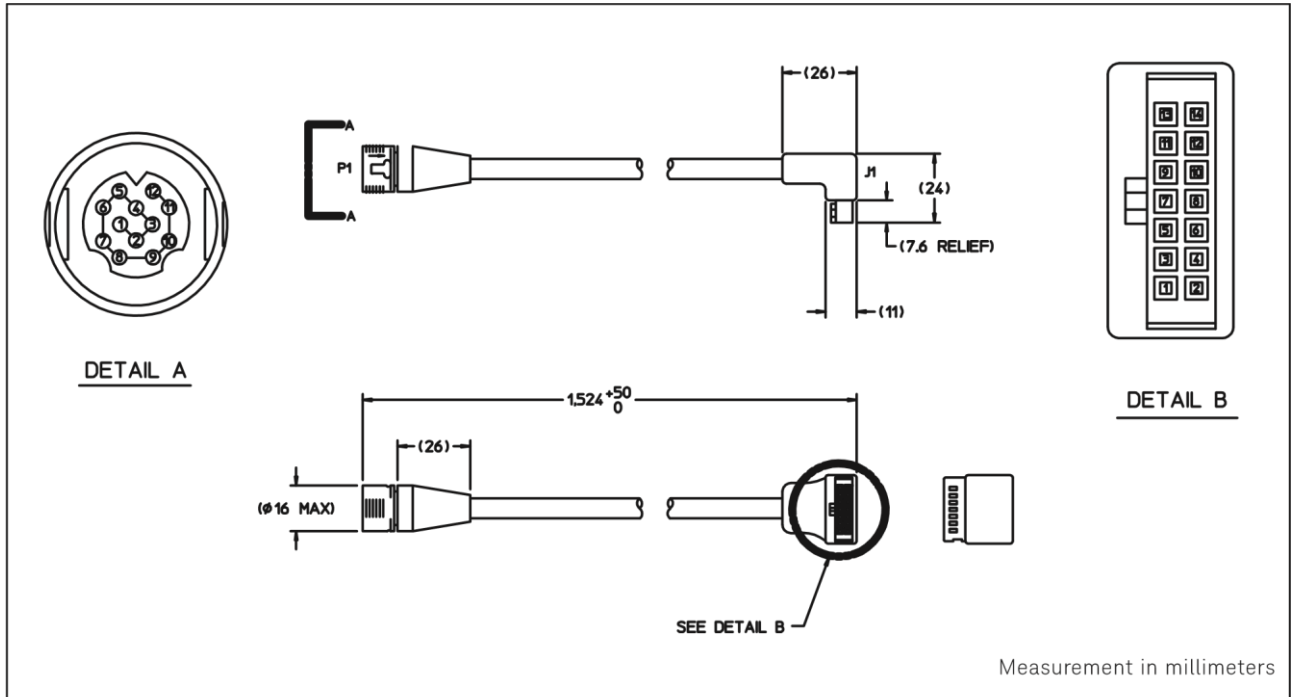

Figure 8. Option 701 Viking connector to 14-pin DIP connector

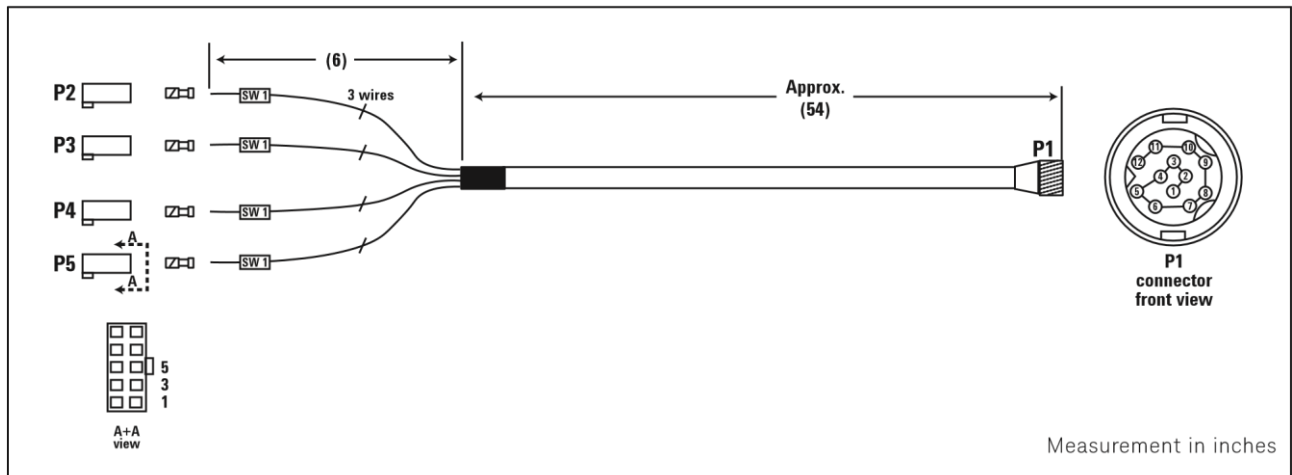

Figure 9. Option 801 Viking connector to (4) 10-pin DIP connector

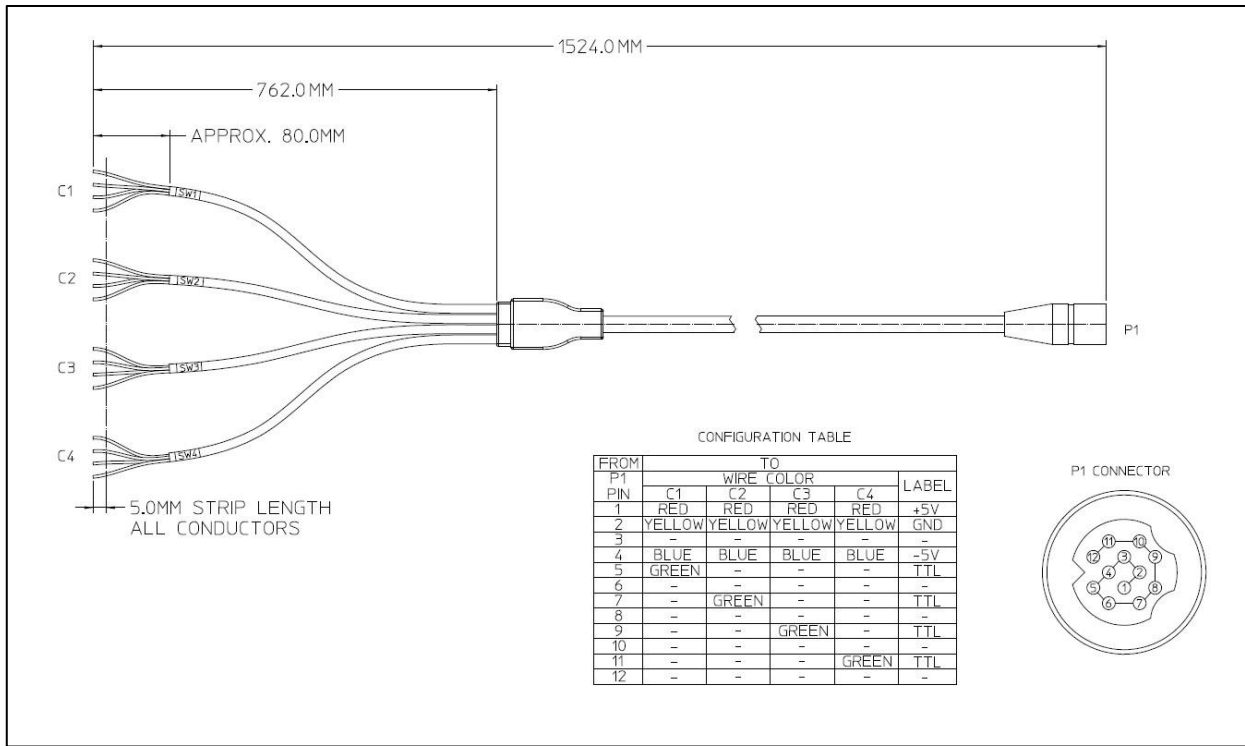

Figure 10. Option 102 Viking connector to 4 cables with 4-conductor bare wires

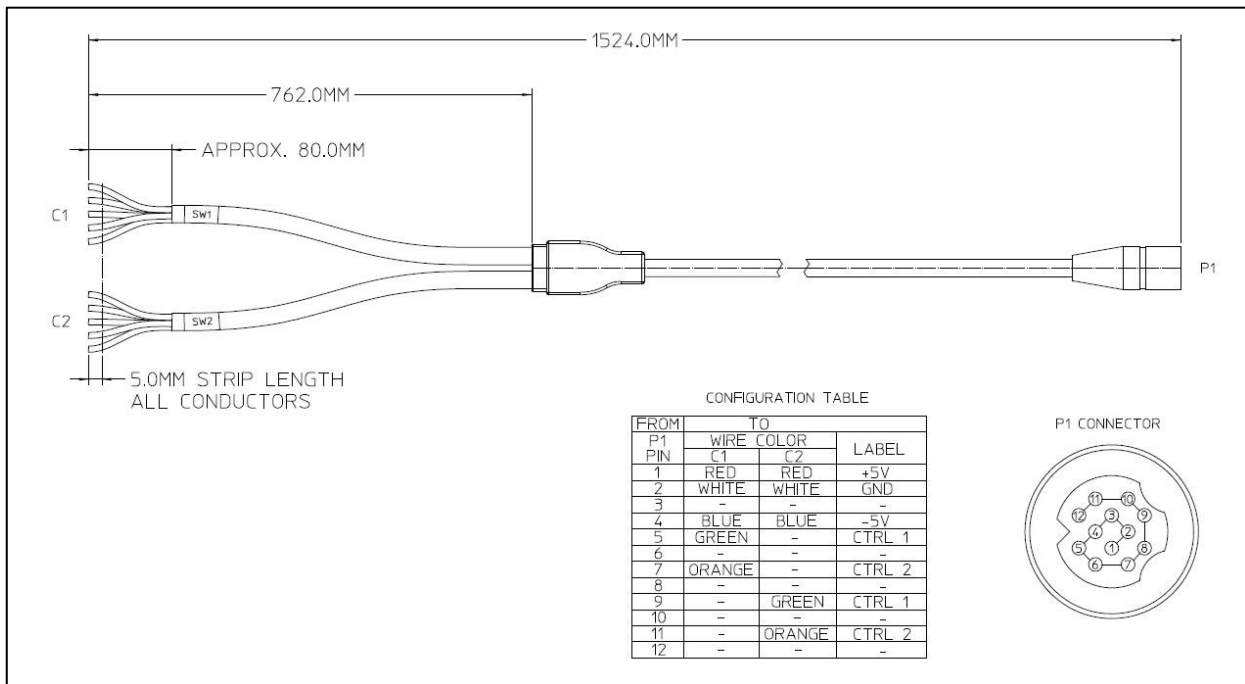

Figure 11. Option 103 Viking connector to 2 cables with 5-conductor bare wire

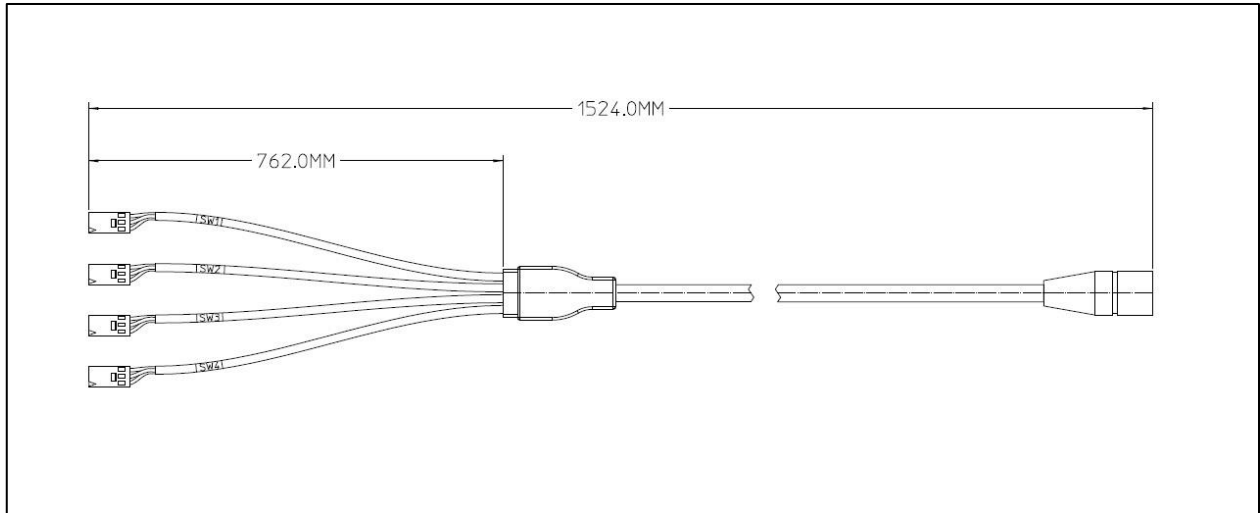

Figure 12. Option 104 Viking connector to 4 cables with 3-pin connector

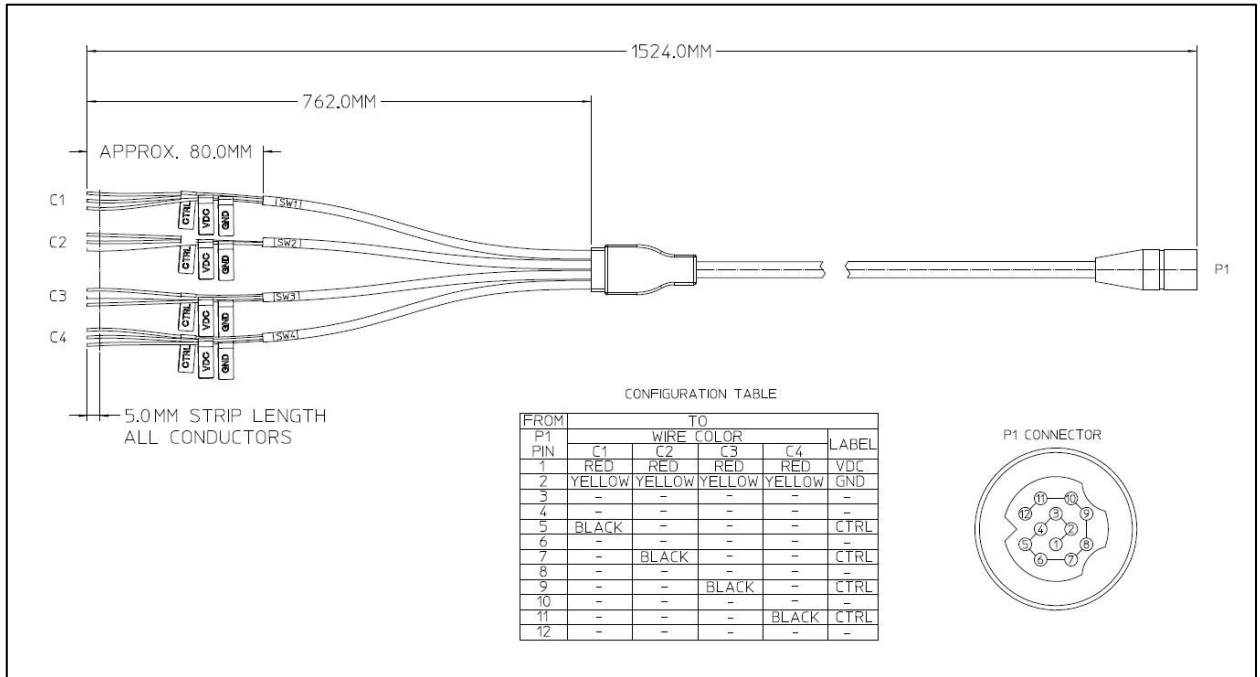

Figure 13. Option 105 Viking connector to 4 cables with 3-conductor bare wires

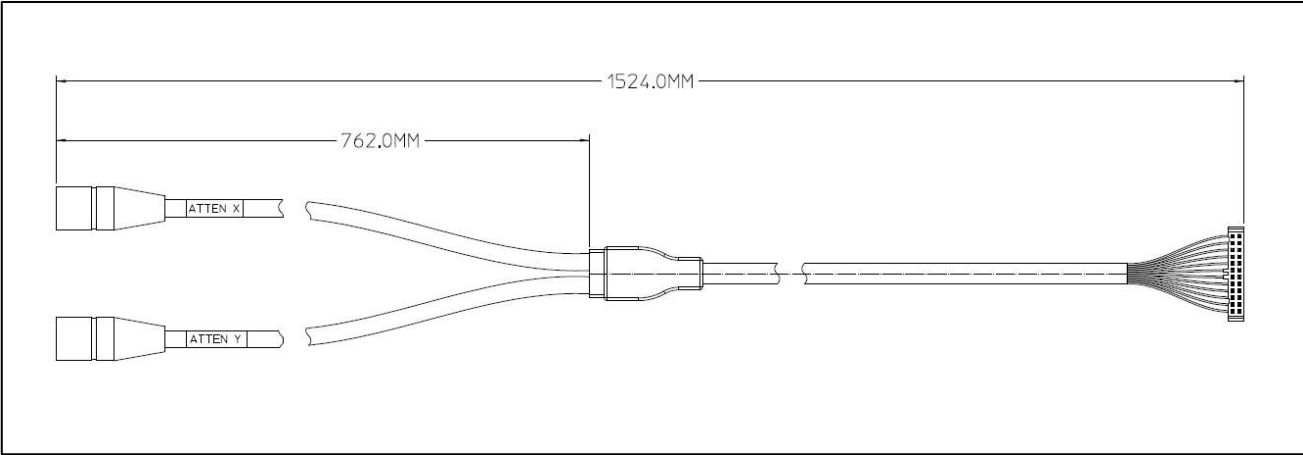

Figure 14. Option 106 Dual-viking connector to 24 pin DIP connector

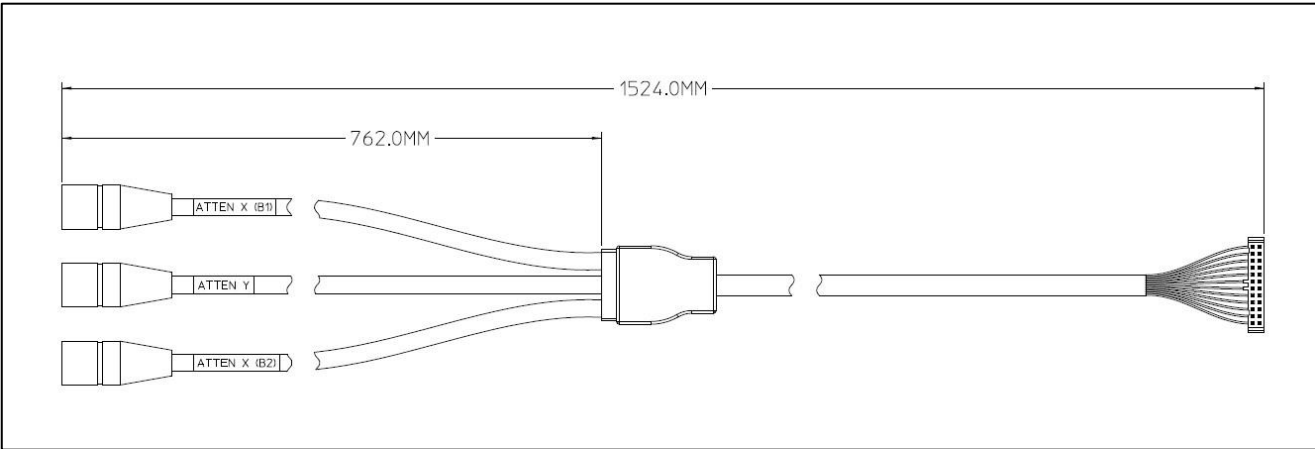

Figure 15. Option 107 Triple-viking connector to 24 pin DIP connector

