

Product Datasheet - Technical Specifications



More information in our Web-Shop at ► www.meilhaus.com

Your contact

Technical and commercial sales, price information,
quotations, demo/test equipment, consulting:

Tel.: +49 - (0)81 41 - 52 71-0

E-Mail: sales@meilhaus.com

Meilhaus Electronic GmbH
Am Sonnenlicht 2
82239 Alling/Germany

Tel. +49 - (0)81 41 - 52 71-0 E-
Mail sales@meilhaus.com

Mentioned company and product names may be registered trademarks of the respective companies. Errors and omissions excepted. © Meilhaus Electronic.



Get Connected.

The channels of the module on slot 1 are available at the 37-pin D-Sub female of the PCI/PCIe data acquisition card and can be connected externally at the PC card bracket. Use the add-on cable ZUKA16 to lead through the connections of the module on the second slot.

Undisturbed and Safe.

The integrated RISC controller generates jitter-free sampling sequences. In addition, the analog channels of the MADDA16II are galvanically isolated from the PC ground. This provides interference-free operation and protects DAQ system and PC against differences of potential.

Modularity. Individuality. Flexibility.

One or two modules can be plugged onto the base boards PCI-BASEII or PCIe-BASE, so that up to 32 analog inputs can be acquired clock-synchronously. In combination with the output module MDA16-4i the base board can be extended by 4 additional analog outputs and used as a powerful control board.

MADDA16II

D/A Converter Module for PCI-BASEII, PCIe-BASE

Assemble DAQ Card. Record and Output Signals. Analog.

For optimal adaptation to a measuring task, the PCI/PCIe cards of BMC Messsysteme GmbH can be equipped with different modules. The analog module MADDA16II is excellently suited for the acquisition of measurement data as well as for analog control tasks.

16 Analog Inputs. 250kHz.

16 Bit. $\pm 10V$, $\pm 5V$, $\pm 2V$, $\pm 1V$.

16 analog inputs can be sampled with 16-bit resolution and 250kHz total sampling rate so that even slightest peaks of high-frequent signals can be detected. The measuring range is selected via software for each channel separately and does not affect the sampling rate.

2 Analog Outputs. 16 Bit. $\pm 10V$.

The two 10V outputs can be used for analog controls with 16-bit accuracy.

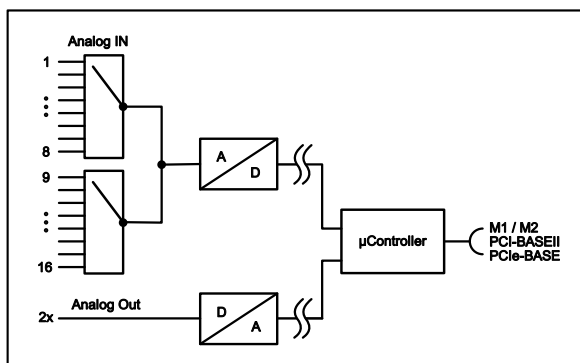

Functional diagram

1 Installation on the PCI-BASEII, PCIe-BASE

The MADDA16II should be installed on slot M1 of the PCI-BASEII/ PCIe-BASE. Thus, all analog inputs and outputs of the MADDA16II are available at the D-Sub37 socket of the PCI/PCIe card.

If two MADDA modules are used on one card, the module with the lower address must use slot M1 and the other one slot M2 (see chapter 2).

The channels of the module on slot M2 can be accessed at the internal pin connectors K3, K4 of the DAQ card. They can be led out to a slot bracket with a D-Sub 37 female connector using the optional ZUKA16 connection cable.

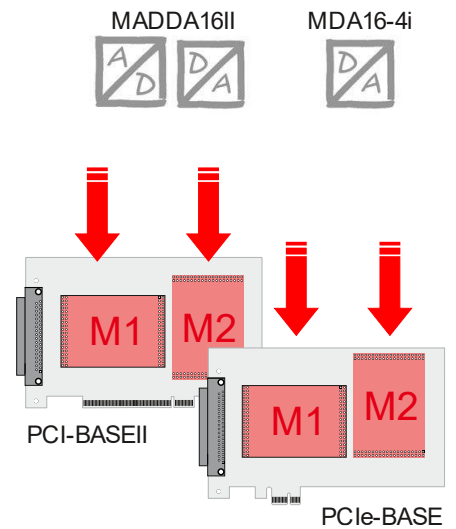

- Make sure the plugs and sockets exactly fit together. If the modules are not plugged correctly, the modules and/or the DAQ card may be damaged
- The modules are electrostatic sensitive devices - please provide for a conductive pad connected to ground during installation.

2 Addressing the MADDA16II Modules

The address configuration is done via the 2-pin solder jumpers JL1 and JL2 on the (component-free) bottom side of the module board.

Address	0	1	2	3
JL1	○ ○	⊗ ⊗	○ ○	⊗ ⊗
JL2	○ ○	○ ○	⊗ ⊗	⊗ ⊗

Address 0 is factory setting

The address determines the assignment of the channels. The MADDA module with the lower address is assigned to the channels 1-16, the MADDA module with the higher address to channel 17-32.

Modulunterseite /
module bottom

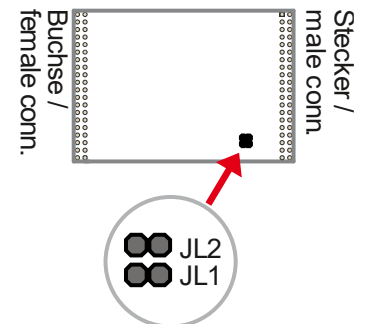

- When using two modules (also of different types), different addresses must be assigned within one measuring card!
- If using two MADDA16II modules on the same DAQ card, the module with the lower address must be placed in slot M1.
- If using two MADDA16II modules, the channels of the module with the lower address are scanned with the preset sampling rate first, then the channels of the module with the higher address.

3 Pin Assignment of the MADDA16II Modules with the PCI/PCIe Card

The following table shows which pins are used for the connection of the analog channels. The channels of the module on the M1 slot are accessible at the 37-pin D-Sub female connector of the DAQ card. The connections of the module on the M2 slot can be accessed at the internal pin connectors K3, K4 of the DAQ card. Additionally, they can be led through to an additional 37-pin D-Sub female connector by means of the add-on cable ZUKA16.

MODULE SLOT M1		MODULE	MODULE SLOT M2	
D-Sub 37 PCI(e)-BASE	Plug/Pin PCI(e)-BASE	MADDA16II	D-Sub 37 ZUKA16	Plug/Pin PCI(e)-BASE
1	K1/1	Aln 1	1	K3/1
2	K1/3	Aln 2	2	K3/3
3	K1/5	Aln 3	3	K3/5
4	K1/7	Aln 4	4	K3/7
5	K1/9	Aln 5	5	K3/9
6	K1/11	Aln 6	6	K3/11
7	K1/13	Aln 7	7	K3/13
8	K1/15	Aln 8	8	K3/15
9	K1/17	Aln 9	9	K3/17
10	K1/19	Aln 10	10	K3/19
11	K2/1	Aln 11	11	K4/1
12	K2/3	Aln 12	12	K4/3
13	K2/5	Aln 13	13	K4/5
14	K2/7	Aln 14	14	K4/7
15	K2/9	Aln 15	15	K4/9
16	K2/11	Aln 16	16	K4/11
17	K2/13	-	17	K4/13
18	K2/15	AOut 1*	18	K4/15
19	K2/17	AOut 2*	19	K4/17
20 .. 29	K1/2, 4, .. 18, 20	AGND	20 .. 29	K3/2, 4, .. 18, 20
30 .. 37	K2/2, 4, .. 14, 16	AGND	30 .. 37	K4/2, 4, .. 14, 16

*only PCI-BASEII from rev. 3.1 on and PCIe-BASE from rev. 3.3 on

- The maximum potentials against ground must not exceed $\pm 10V$! Any channel overload may influence measurements of other channels and may lead to wrong values.
- Open inputs show any, non-predicative voltages.
- If the MADDA16II is used with older versions of the PCI/PCIe data acquisition cards (PCI-BASE300, PCI-BASE1000, PCI-BASEII to rev. 3.0, PCIe-BASE to rev. 3.2), only the 16 analog inputs but not the two analog outputs are available.

4 Important Notes for Using the MADDA16II

- The modules are only suitable for extra-low voltages - please observe the relevant regulations! The modules must only be used in closed PC housings (for reasons relating to EMC).
- All accessible pins are electrostatic sensitive devices. Provide for a grounded conductive work place.
- Only use non-solvent detergents for cleaning. The product is designed to be maintenance-free.
- The product must not be used for safety-relevant tasks. With the use of the product, the customer becomes manufacturer by law and is therefore fully responsible for the proper installation and use of the product. In the case of improper use and/or unauthorized interference, our warranty ceases and any warranty claim is excluded.
- Improper installation of the modules on the PCI/PCIe card may damage the modules and/or the DAQ card. Exposing the card to strong vibrations requires additional protection of the module
- The signal ground of the MADDA16II has no galvanic connection with the ground of the PC. To avoid measurement errors, make sure that no ground or earth loops occur.
- The modules are equipped with EEPROMS, in which the parameters of the modules are stored. The included software drivers read them out and correct the offset if necessary. Gain errors are documented in the test report and may be adjusted in the measuring software. The measuring range is shifted by the offset values resulting in the fact that measurements in the upper ranges may exceed or underlie the true values.
- The gain is adjusted to "even" values. Therefore, only 64000 values (for 16 bit) of the full converter range are used. As a result, the measuring ranges are slightly larger (e.g., $\pm 10.24V$) than the indicated measuring ranges, providing the advantage that overranges can be recognized.
- The AD converter of the MADDA16II module has a code noise of up to ± 2 LSB. For 16-bit accuracy, you must average at least 10 times in order to suppress the noise.
- If connecting internal ribbon cables to the PCI/PCIe base board, please make sure the modules are well ventilated to prevent excess heating. Also observe the temperature ranges of the PC.



Do not dispose of the product in the domestic waste or at any waste collection place. It has to be either duly disposed according to the WEEE directive or can be returned to bmcm at your own expense.

5 Technical Data (typical at 20°C, after 5min.)

• Analog Inputs

Channels // Meas. ranges* // Resolution:	16 inputs, electrically isolated from PC // $\pm 10V$, $\pm 5V$, $\pm 2V$, $\pm 1V$ // 16 bit
Total sample rate** // min. sample rate/cha:	250kHz // 4 μ s
Converter error:	typ. ± 2 LSB
Accuracy***:	typ. $\pm 0,1\%$
Surge protection:	max. $\pm 35V$ (when turned on), max. $\pm 20V$ (when turned off), max. $\pm 20mA$ in total of all input channels!
Skew (jitter) with 32-channel operation:	max. 1 μ s between 1. + 2. module
Input resistance // Input capacity:	1M Ω (with PC turned off: 1k Ω) // 5pF
Zero shift // Gain drop:	typ. $\pm 36ppm/K$ // typ. 35ppm/K
Frequency accuracy:	max. $\pm 20ppm$

* The MADDA16II modules are factory set in the range of $\pm 5V$. The measuring range can be set for each channel separately.

** The total sampling rate is the sum of the sampling rates of all used channels (e.g., 5 channels à 10kHz => 50kHz total sampling rate).

*** Errors can add up in the worst case.

• Analog Outputs

Channels // Output range // Resolution:	2 outputs, electrically isolated from PC // $\pm 10V$ // 16 Bit
Temperature drift:	Offset typ. $\pm 25ppm/K$ / Amplification typ. $\pm 30ppm/K$
Output current // Output resistance:	max. 1mA // $< 10\Omega$
Relative accuracy:	± 1 LSB

• General Data

Power supply:	+4,5V..+5,5V from PCI-BASEII or PCIe-BASE, max. 200mA
CE standards:	EN61000-6-1, EN61000-6-3, EN61010-1; for decl. of conformity (PDF) visit www.bmcm.de
ElektroG // ear registration:	RoHS and WEEE compliant // WEEE Reg.-No. DE75472248
Max. perm. potentials:	60V DC acc. to VDE , max. 1kV ESD on open lines
Temperature ranges // Relative humidity:	operating temp.: -25°C..50°C, storage temp.: -25°C..70°C // 0-90% (not condensing)
Dimensions // Delivery:	approx. 74 x 52 x 13 mm ³ // product, description
Warranty:	2 years from date of purchase at bmcm, claims for damages resulting from improper use excluded