

## Product Datasheet - Technical Specifications



More information in our Web-Shop at ► [www.meilhaus.com](http://www.meilhaus.com) and in our download section.

### Your contact

Technical and commercial sales, price information,  
quotations, demo/test equipment, consulting:

Tel.: **+49 - 81 41 - 52 71-0**

FAX: **+49 - 81 41 - 52 71-129**

E-Mail: [sales@meilhaus.com](mailto:sales@meilhaus.com)

Downloads:

[www.meilhaus.com/en/infos/download.htm](http://www.meilhaus.com/en/infos/download.htm)

Meilhaus Electronic GmbH | Tel. **+49 - 81 41 - 52 71-0**  
Am Sonnenlicht 2 | Fax **+49 - 81 41 - 52 71-129**  
82239 Alling/Germany | E-Mail [sales@meilhaus.com](mailto:sales@meilhaus.com)

Mentioned company and product names may be registered trademarks of the respective companies. Prices in Euro plus VAT. Errors and omissions excepted.  
© Meilhaus Electronic.

# DSCA30/31



## Analog Voltage Input Signal Conditioners, Narrow Bandwidth

### Description

Each DSCA30/31 voltage input module provides a single channel of analog input which is filtered, isolated, amplified, and converted to a high-level voltage output (Figure 1). Signal filtering is accomplished with a five-pole filter which provides 85dB of normal-mode rejection at 60Hz and 80dB at 50Hz. An anti-aliasing pole is located on the field side of the isolation barrier, and the other four poles are on the system side. After the initial field-side filtering, the input signal is chopped by a proprietary chopper circuit. Isolation is provided by transformer coupling, again using a proprietary technique to suppress transmission of common mode spikes or surges.

Module output is either voltage or current. For current output models a dedicated loop supply is provided at terminal 3 (+OUT) with loop return located at terminal 4 (-OUT). The system-side load may be either floating or grounded.

Special input circuits provide protection against accidental connection of power-line voltages up to 240VAC and against transient events as defined by ANSI/IEEE C37.90.1. Protection circuits are also present on the signal output and power input terminals to guard against transient events and power reversal. Signal and power lines are secured to the module using screw terminals which are in pluggable terminal blocks for ease of system assembly and reconfiguration.

The modules have excellent stability over time and do not require recalibration, however, zero and span settings are adjustable up to  $\pm 5\%$  to accommodate situations where fine-tuning is desired. The adjustments are made using potentiometers located under the front panel label and are non-interactive for ease of use.

### Features

- Accepts Millivolt and Voltage Level Signals
- Industry Standard Output of 0 to +10V,  $\pm 10V$ , 0 to 20mA, or 4 to 20mA
- 1500Vrms Transformer Isolation
- ANSI/IEEE C37.90.1 Transient Protection
- Input Protected to 240VAC Continuous
- True 3-Way Isolation
- Wide Range of Supply Voltage
- 160dB CMR
- 85dB NMR at 60Hz, 80dB at 50Hz
- $\pm 0.03\%$  Accuracy
- $\pm 0.01\%$  Linearity
- Easily Mounts on Standard DIN Rail
- C-UL-US Listed
- CE and ATEX Compliant

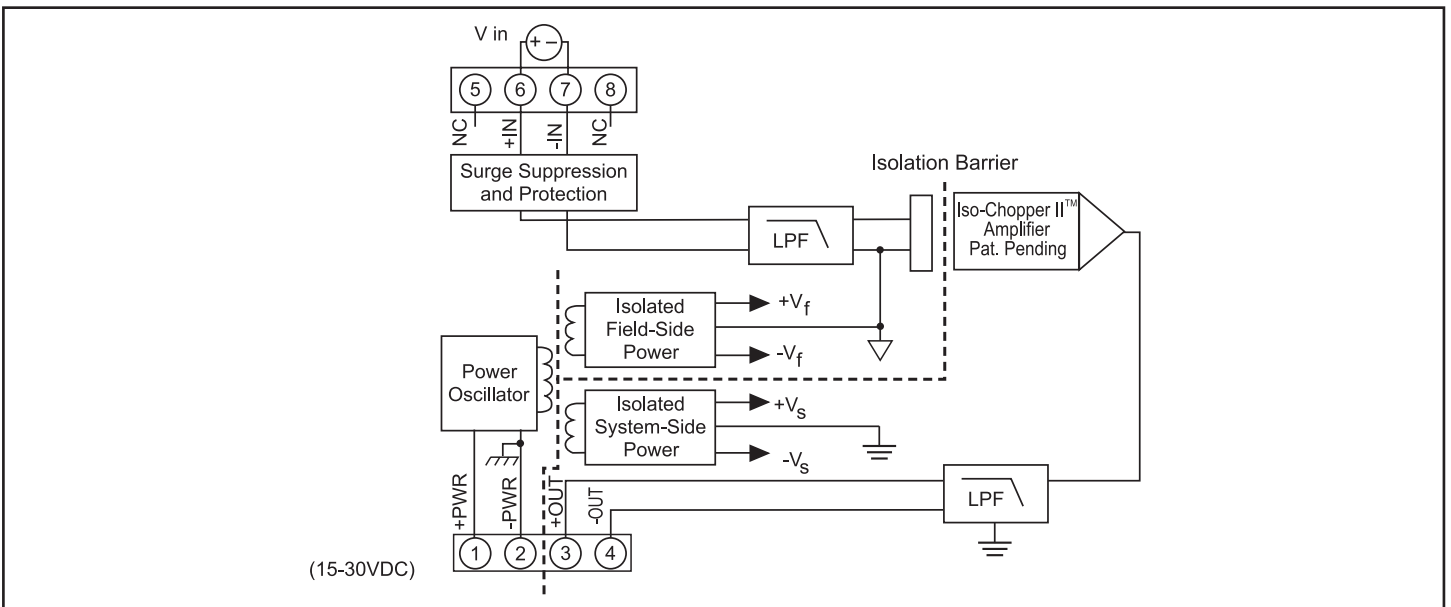

Figure 1: DSCA30/31 Block Diagram

**Specifications** Typical\* at  $T_A = +25^\circ\text{C}$  and +24VDC supply voltage

Module	DSCA30	DSCA31
Input Range	$\pm 10\text{mV}$ to $\pm 100\text{mV}$	$\pm 1\text{V}$ to $\pm 40\text{V}$
Input Bias Current	$\pm 0.5\text{nA}$	$\pm 0.05\text{nA}$
Input Resistance		
Normal	50M $\Omega$	500k $\Omega$ min
Power Off	65k $\Omega$	500k $\Omega$ min
Overload	65k $\Omega$	500k $\Omega$ min
Input Protection		
Continuous	240Vrms max	*
Transient	ANSI/IEEE C37.90.1	*
Output Range	See Ordering Information	
Load Resistance ( $I_{OUT}$ )	600 $\Omega$ max	*
Current Limit	8mA ( $V_{OUT}$ ), 30mA ( $I_{OUT}$ )	*
Output Protection		
Short to Ground	Continuous	*
Transient	ANSI/IEEE C37.90.1	*
CMV, Input to Output, Input to Power		
Continuous	1500Vrms max	*
Transient	ANSI/IEEE C37.90.1	*
CMV, Output to Power		
Continuous	50VDC max	*
CMR (50Hz or 60Hz)	160dB	*
Accuracy <sup>(1)</sup>	$\pm 0.03\%$ Span	*
Linearity	$\pm 0.01\%$ Span	*
Adjustability	$\pm 5\%$ Zero and Span	*
Stability		
Input Offset	$\pm 0.5\mu\text{V}/^\circ\text{C}$	$\pm 5\mu\text{V}/^\circ\text{C}$
Output Offset	$\pm 6\text{ppm}/^\circ\text{C}$ ( $V_{OUT}$ ), $\pm 20\text{ppm}/^\circ\text{C}$ ( $I_{OUT}$ )	*
Zero Suppression	$\pm 50\text{ppm}(V_z)^{2}/^\circ\text{C}$	*
Gain	$\pm 35\text{ppm}/^\circ\text{C}$	$\pm 55\text{ppm}/^\circ\text{C}$
Output Noise, 100kHz BW	250 $\mu\text{Vrms}$ ( $V_{OUT}$ ), 1 $\mu\text{Arms}$ ( $I_{OUT}$ )	*
Bandwidth, -3dB	3Hz	*
NMR	85dB at 60Hz, 80dB at 50Hz	*
Response Time, 90% Span	165ms	*
Power Supply		
Voltage	15 to 30VDC	*
Current	25mA ( $V_{OUT}$ ), 55mA ( $I_{OUT}$ )	*
Sensitivity	$\pm 0.0001\%$ %	*
Protection		
Reverse Polarity	Continuous	*
Transient	ANSI/IEEE C37.90.1	*
Mechanical Dimensions (h)(w)(d)	2.95" x 0.89" x 4.13" (75mm x 22.5mm x 105mm)	*
Mounting	DIN EN 50022 -35x7.5 or -35x15 rail	*
Environmental		
Operating Temp. Range	$-40^\circ\text{C}$ to $+80^\circ\text{C}$	*
Storage Temp. Range	$-40^\circ\text{C}$ to $+80^\circ\text{C}$	*
Relative Humidity	0 to 95% Noncondensing	*
Emissions EN61000-6-4	ISM, Group 1	*
Radiated, Conducted	Class A	*
Immunity EN61000-6-2	ISM, Group 1	*
RF	Performance A $\pm 0.5\%$ Span Error	*
ESD,EFT	Performance B	*

**NOTES:**

\*Contact factory or your local Dataforth sales office for maximum values.

\* Same specification as DSCA30.

(1) Includes linearity, hysteresis and repeatability.

 (2)  $V_z$  is the nominal input voltage that results in 0V or 0mA output.

**Ordering Information**

Model	Input Range	Output Range †
DSCA30-01	$-10\text{mV}$ to $+10\text{mV}$	1
DSCA30-02	$-50\text{mV}$ to $+50\text{mV}$	1
DSCA30-03	$-100\text{mV}$ to $+100\text{mV}$	1
DSCA30-04	$-10\text{mV}$ to $+10\text{mV}$	2, 3, 4
DSCA30-05	$-50\text{mV}$ to $+50\text{mV}$	2, 3, 4
DSCA30-06	$-100\text{mV}$ to $+100\text{mV}$	2, 3, 4
DSCA30-07	0 to $+10\text{mV}$	2, 3, 4
DSCA30-08	0 to $+50\text{mV}$	2, 3, 4
DSCA30-09	0 to $+100\text{mV}$	2, 3, 4
DSCA31-01	$-1\text{V}$ to $+1\text{V}$	1
DSCA31-02	$-5\text{V}$ to $+5\text{V}$	1
DSCA31-03	$-10\text{V}$ to $+10\text{V}$	1
DSCA31-04	$-1\text{V}$ to $+1\text{V}$	2, 3, 4
DSCA31-05	$-5\text{V}$ to $+5\text{V}$	2, 3, 4
DSCA31-06	$-10\text{V}$ to $+10\text{V}$	2, 3, 4
DSCA31-07	$-20\text{V}$ to $+20\text{V}$	1
DSCA31-08	$-20\text{V}$ to $+20\text{V}$	2, 3, 4
DSCA31-09	$-40\text{V}$ to $+40\text{V}$	1
DSCA31-10	$-40\text{V}$ to $+40\text{V}$	2, 3, 4
DSCA31-11	0 to $+1\text{V}$	2, 3, 4
DSCA31-12	0 to $+5\text{V}$	2, 3, 4
DSCA31-13	0 to $+10\text{V}$	2, 3, 4
DSCA31-14	0 to $+20\text{V}$	2, 3, 4
DSCA31-15	0 to $+40\text{V}$	2, 3, 4

**†Output Ranges Available**

Output Range	Part No. Suffix	Example
1. $-10\text{V}$ to $+10\text{V}$	NONE	DSCA30-01
2. 0V to $+10\text{V}$	NONE	DSCA30-04
3. 4 to 20mA	C	DSCA30-04C
4. 0 to 20mA	E	DSCA30-04E

**Installation Notes:**

- 1.) This Equipment is Suitable for Use in Class I, Division 2, Groups A, B, C, D, or Non-Hazardous Locations Only.
- 2.) WARNING - Explosion Hazard - Substitution of Components May Impair Suitability for Class I, Division 2.
- 3.) WARNING - Explosion Hazard - Do Not Disconnect Equipment Unless Power Has Been Switched Off or The Area is Known to be Non-Hazardous.
- 4.) The Power to These Devices Shall Be Limited by an Over-Current Protection Device, UL Certified Fuse (JDYX/JDYX2) Rated 6A Max.