

Product Datasheet - Technical Specifications



More information in our Web-Shop at ► www.meilhaus.com

Your contact

Technical and commercial sales, price information,
quotations, demo/test equipment, consulting:

Tel.: +49 - (0)81 41 - 52 71-0

E-Mail: sales@meilhaus.com

Meilhaus Electronic GmbH
Am Sonnenlicht 2
82239 Alling/Germany

Tel. +49 - (0)81 41 - 52 71-0 E-
Mail sales@meilhaus.com

Mentioned company and product names may be registered trademarks of the respective companies. Errors and omissions excepted. © Meilhaus Electronic.

DT9837 Series

High Performance, USB Powered Modules for Sound & Vibration Analysis

Overview

The DT9837 Series high-accuracy dynamic signal acquisition modules are ideal for portable noise, vibration, and acoustic measurements. Four, 24-bit, IEPE (ICP®) sensor inputs are synchronized with a tachometer input (depending on model) to provide data streams that are matched in time, for field and laboratory use. These rugged, compact modules are USB powered, making them ideal for portable measurement applications.

Key Features

- Runs on USB Power – ideal for portable applications
- Four Simultaneous, 24-bit Delta-Sigma A/D converters for high resolution measurements
- Support for IEPE (Integrated Electronic Piezoelectric) inputs, including use of a 2 mA or 4 mA current source and AC or DC coupling
- Up to 105.4 kS/s sample rate per channel
- Input range of ± 10 V with software-selectable gains of 1 and 10 for an effective input range of ± 10 V and ± 1 V, respectively
- For DT9837C modules only, 1 Hz high-pass filter on analog input subsystem
- Return the value of tachometer counter 0 in the analog input data stream, to measure the period or frequency of the tachometer input signal synchronously with analog input measurements
- For the DT9837A and DT9837B modules only, the ability to read the value of tachometer counter 1 in the analog input data stream, allowing you to precisely correlate tachometer measurements with analog input measurements
- For the DT9837A-OEM and DT9837B modules only, the ability to read the value of gate counter 2 in the analog input data stream, allowing you to precisely correlate gate input measurements with analog input measurements
- For the DT9837A modules only, support for reading analog output values in the analog input data stream, allowing you to correlate input and output values
- Software-programmable trigger source (software trigger, external digital trigger, or analog threshold trigger) to start the analog input operation.
- Internal clock source (shared between the analog input and analog output subsystems)
- For the DT9837A, DT9837B, and DT9837C modules only, RJ45 synchronization (LVDS) connector for synchronizing acquisition on up to four modules
- BNC connectors for all models

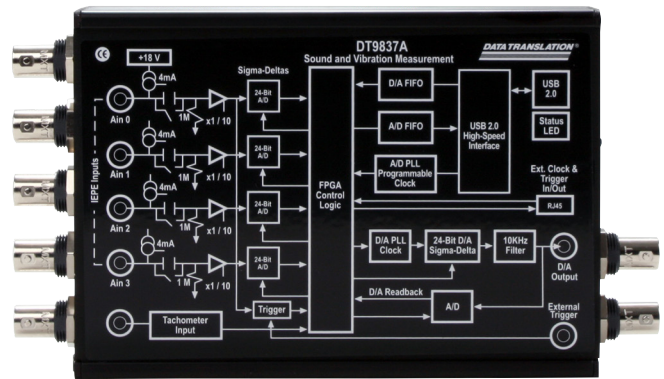

The DT9837A has 4 simultaneous IEPE sensor inputs plus a synchronous tachometer input and is ideal for portable noise and vibration measurement applications.

Analog output subsystem (DT9837)

- One 24-bit D/A converter
- Waveform capability of up to 8,192 sample
- Update rate of 46.875 kS/s
- Output range of ± 10 V
- A software trigger starts the analog output operation

Analog output subsystem (DT9837A)

- One 24-bit D/A converter
- Single value, waveform, and continuous streaming output
- Programmable output rate from 10 kS/s to 52.734 kS/s
- Output range of ± 10 V
- ± 3 mA output current
- Software-programmable trigger source (software trigger, external digital trigger, or analog threshold trigger) to start the analog output operation.

Analog output subsystem (DT9837C)

- One 24-bit D/A converter
- Single value, waveform, and continuous streaming output
- Programmable output rate from 10 kS/s to 96 kS/s
- Output range of ± 3 V
- ± 2 mA output current
- Software-programmable trigger type (software trigger, external digital trigger, or analog threshold trigger) to start the analog output operation.

Supported Operating Systems

- Windows® 10/8/7/Vista® 32/64-bit
- Linux® (supported by DT9837A, DT9837B, and DT9837C modules only)

| | DT9837 | DT9837A | DT9837B | DT9837C |
|--|-----------------------|---|------------------|---|
| Analog Input Features | | | | |
| 4, single-ended, simultaneous channels | ✓ | ✓ | ✓ | ✓ |
| 24-bit Resolution | ✓ | ✓ | ✓ | ✓ |
| High-Pass Filter | 0.5 Hz | 0.1 Hz | 0.5 Hz | 1 Hz |
| AC/DC Coupling | ✓ | ✓ | ✓ | ✓ |
| Current Source | 4 mA | 4 mA | 4 mA | 2 mA |
| Maximum Sample Rate/Ch | 52.7 kS/s | 52.7 kS/s | Up to 105.4 kS/s | 105.4 kS/s |
| A/D Threshold Trigger | Fixed | Programmable | Programmable | Programmable |
| 1 Tachometer | ✓ | ✓ | ✓ | – |
| ±30 V Tachometer Input Range | ✓ | ✓ | ✓ | – |
| Gate Input* | – | ✓ | ✓ | – |
| Analog Output Readback Capability | – | ✓ | – | – |
| Analog Output Features | | | | |
| 1 Channel | ✓ | ✓ | – | ✓ |
| | Single Value | Waveform Streaming | – | Waveform Streaming |
| 24-bit Resolution | ✓ | ✓ | – | ✓ |
| Maximum Sample Rate | 46.875 kS/s (fixed) | 52.7 kS/s | – | 96 kS/s |
| Streaming Mode | – | ✓ | – | ✓ |
| Buffer Mode | ✓ | ✓ | – | ✓ |
| Trigger Types | Software trigger only | Software trigger, external digital trigger, or analog threshold trigger | – | Software trigger, external digital trigger, or analog threshold trigger |
| Other Features | | | | |
| Multiple Module Synchronization | – | ✓ | ✓ | ✓ |
| Connectors | BNC | BNC | BNC | BNC |

*Available on the DT9837A-OEM version. Available through BNC connector on the DT9837B module.

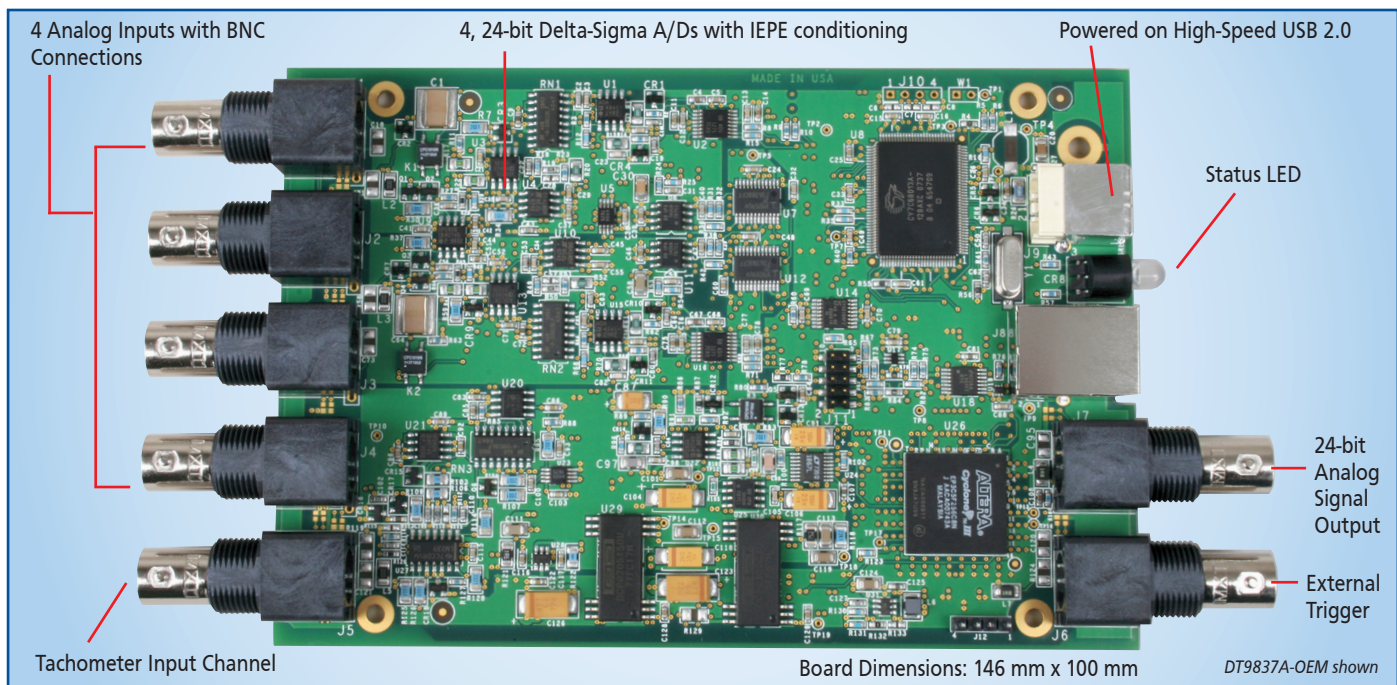

A board-level version of the DT9837A is available (DT9837A-OEM). These modules provide BNC connectors for easy signal connections. The DT9837A-OEM provides an additional gate input connector for precisely correlating analog input and gate input measurements.

DT9837 Block Diagram

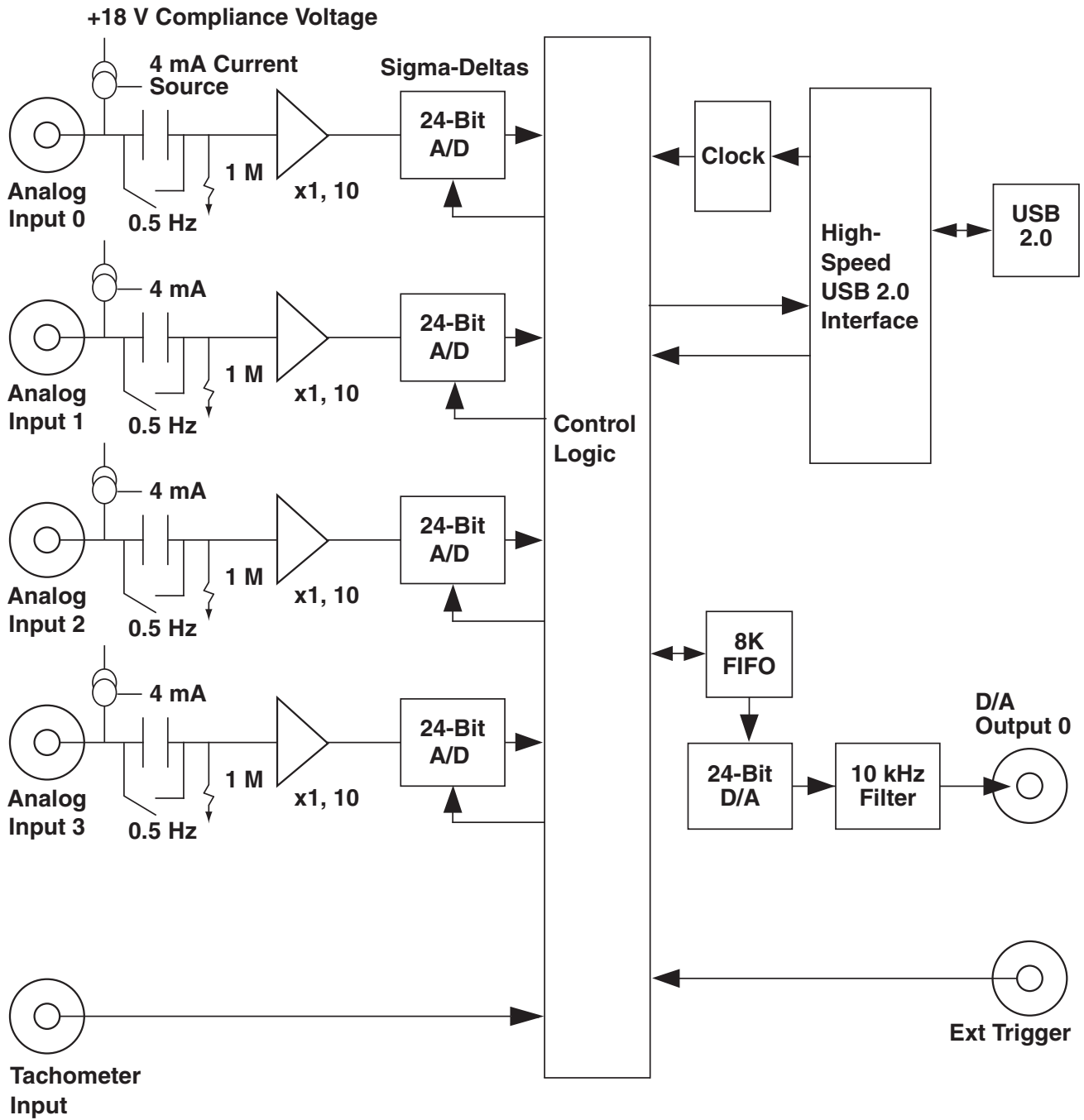

DT9837 Block Diagram

DT9837A Block Diagram

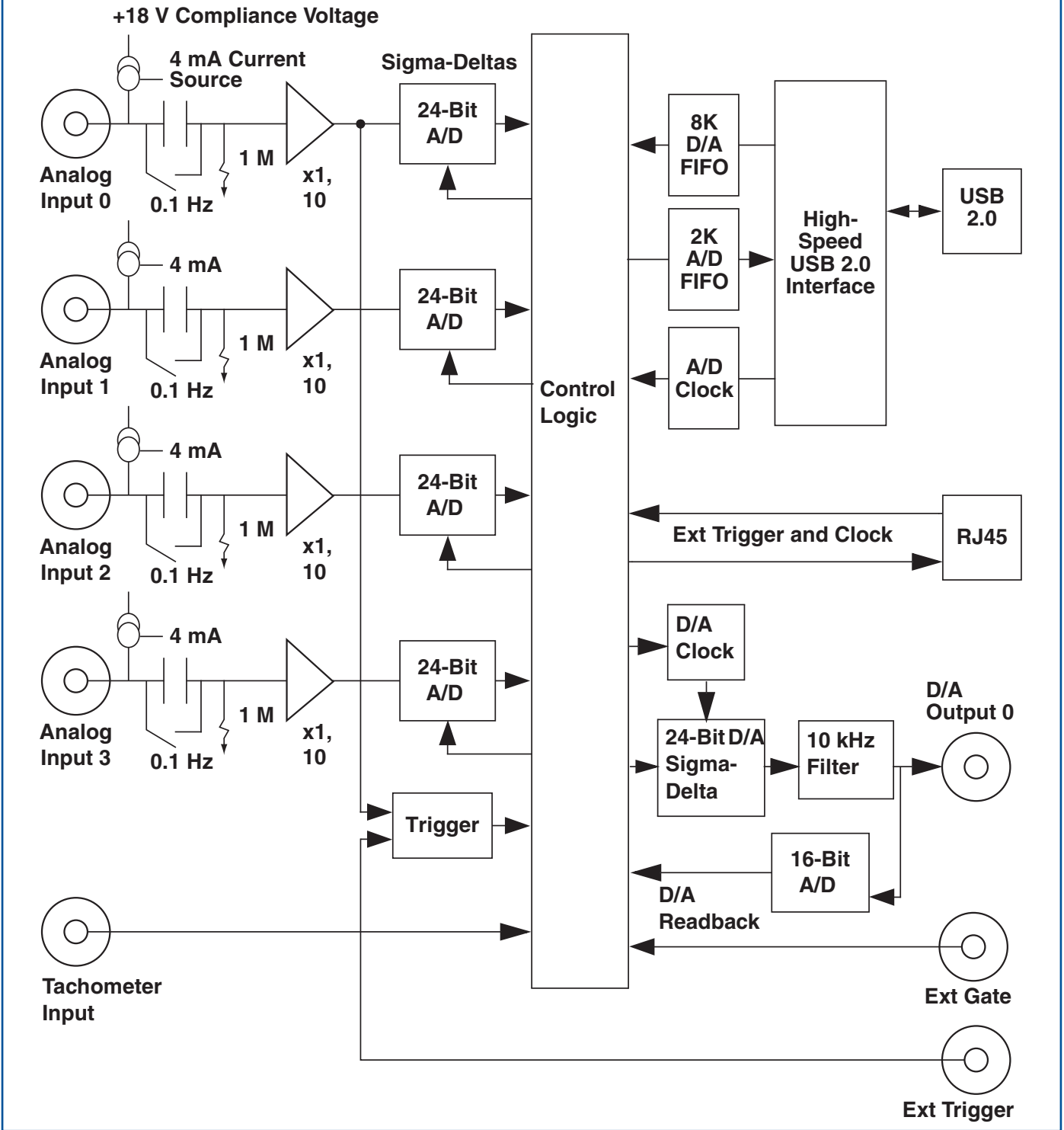

DT9837A Block Diagram

DT9837B Block Diagram

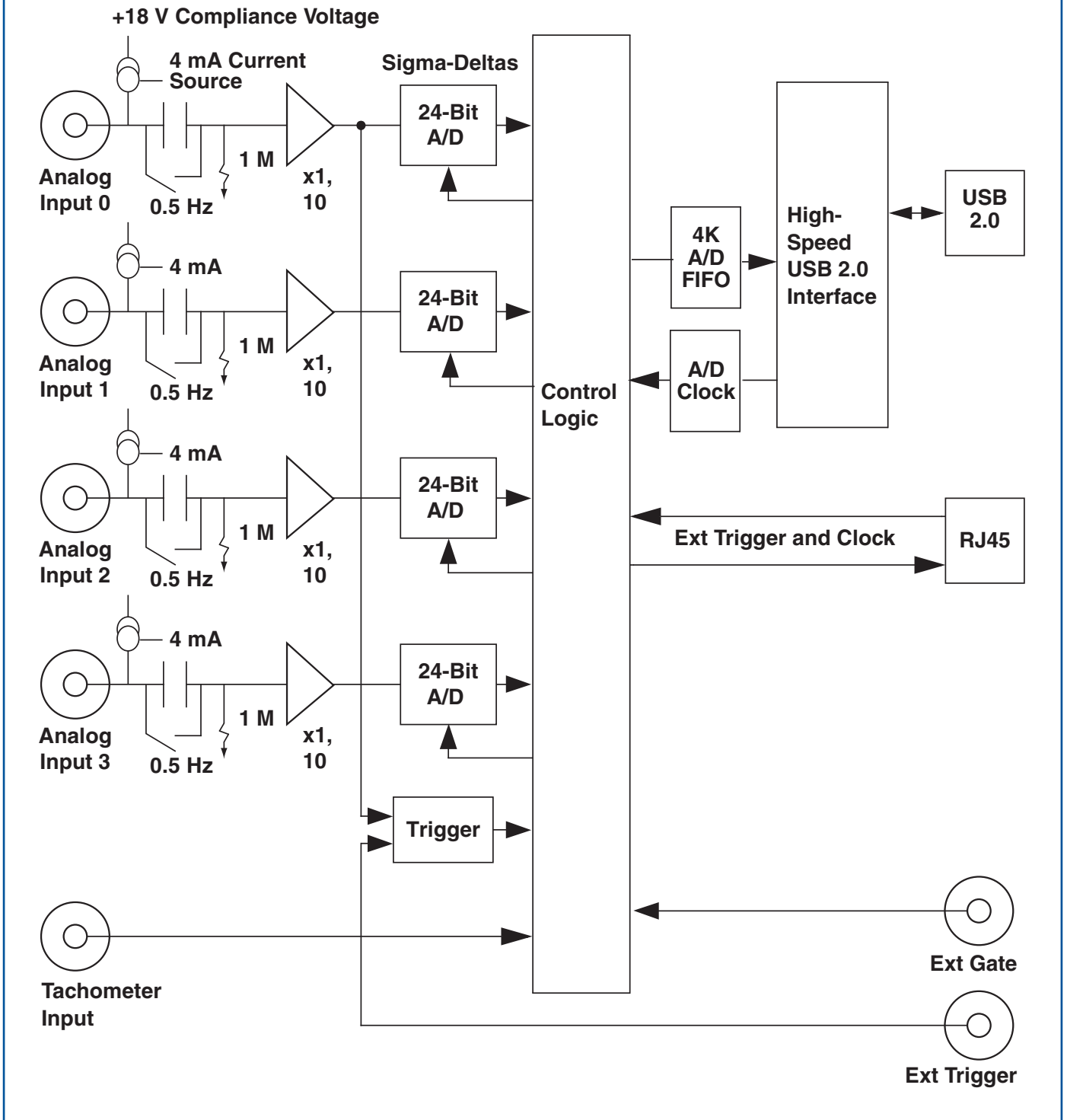

DT9837B Block Diagram

DT9837C Block Diagram

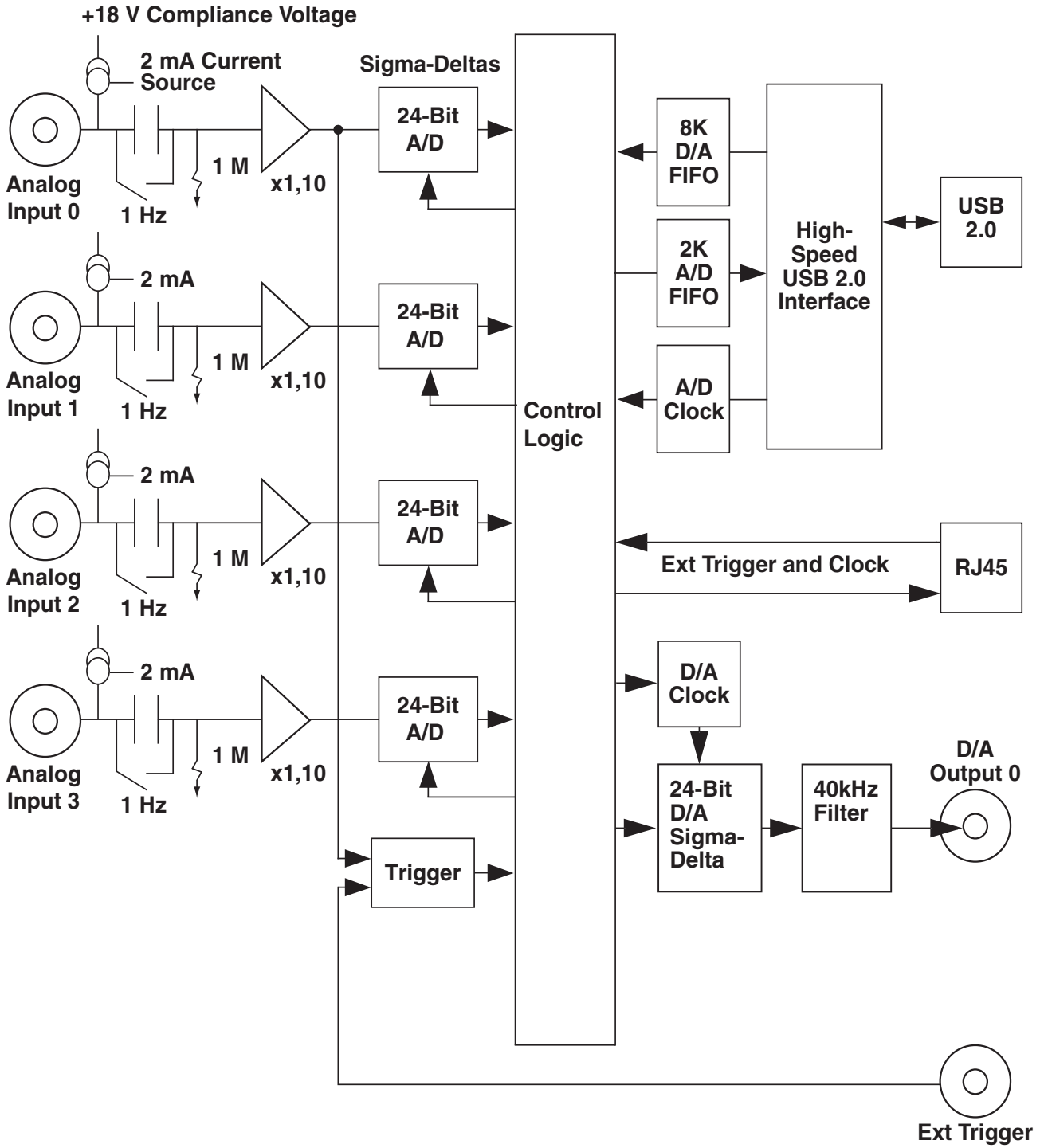

DT9837C Block Diagram

Analog Input Channels

The DT9837 Series modules support four, single-ended analog input channels. All analog input channels are simultaneously clocked. Software-selectable gains of 1 and 10 provide effective input ranges of ± 10 V and ± 1 V, respectively. The DT9837 Series modules use 24-bit Delta-Sigma analog-to-digital converters (ADCs) that provide anti-aliasing filters based on the clock rate. These filters remove aliasing, which is a condition where high frequency input components erroneously appear as lower frequencies after sampling.

IEPE Functions

Applications that require accelerometer, vibration, noise, or sonar measurements often use IEPE sensors. IEPE conditioning is built-in to the analog input circuitry of the DT9837 Series modules. The modules support the following software-programmable IEPE functions for each of the four analog inputs:

- **Excitation current source** – The DT9837, DT9837A, and DT9837B modules provide an internal excitation current source of 4 mA. The DT9837C module provides an internal excitation current source of 2 mA.
- **Coupling type** – AC coupling or DC coupling can be selected.

The DT9837C also provides a 1 Hz high-pass filter.

Programmable A/D Clock

The DT9837 Series modules support an internal clock, which is derived from the USB clock. Use software to specify the internal clock source and the frequency at which to pace the input and output operations and to start the sample clock. For the DT9837 and DT9837A, the sampling frequency ranges from 195.3 Hz to 52.734 kHz. For the DT9837B and DT9837C, the sampling frequency ranges from 195.3 Hz to 105.469 kHz.

Input Triggers

A trigger is an event that occurs based on a specified set of conditions.

The DT9837 Series modules support the following input trigger sources for the start trigger:

- **Software trigger** – A software trigger event occurs when you start the analog input operation in software.
- **External digital (TTL) trigger** – An external digital (TTL) trigger event occurs when the module detects a rising-edge transition on the signal connected to the Ext Trig BNC connector on the module.

- **Analog threshold trigger** – For the DT9837 module only, the start trigger event occurs when the signal attached to analog input channel 0 rises above 1.0 V (the fixed threshold level). Specify the start trigger source as a positive threshold trigger, and the threshold trigger channel as channel 0.

For the DT9837A and DT9837B modules, the start trigger event occurs when the signal attached to analog input channel 0 rises above a user-specified threshold value. Using software, specify the start trigger source as a positive threshold trigger, the threshold trigger channel as channel 0, and the threshold level as a value between 0.2 V to 9.8 V.

For the DT9837C module, the start trigger event occurs when the signal attached to a specified analog input channel in the channel list rises or falls below a user-specified threshold value. Any of the analog input channels can be used as the start trigger. The threshold value is programmable (± 10 V for a gain of 1 or ± 1 V for a gain of 10).

Tachometer Input Features

The DT9837, DT9837A, and DT9837B modules accept one ± 30 V, 32-bit tachometer input signal. (The DT9837C does not support a tachometer input.) On the DT9837, this signal has a maximum frequency of 380 kHz and a minimum pulse width of 1.3 μ s. On the DT9837A and DT9837B, this signal has a maximum frequency of 1 MHz and a minimum pulse width of 0.4 μ s. The threshold voltage is fixed at +2 V with 0.5 V of hysteresis.

You can measure the frequency or period of the tachometer input signal using tachometer counter 0. On the DT9837A and DT9837B modules, you can also measure the phase of the tachometer input signal in relation to the A/D sample using tachometer counter 1.

Frequency or Period Measurements – Tachometer Counter 0

Use frequency or period measurements to calculate the rotation speed for high-level (± 30 V) tachometer input signals. An internal 12 MHz counter (tachometer counter 0) is used for the measurement, yielding a resolution of 83 ns (1/12 MHz).

The following parameters for tachometer counter 0 can be configured:

- The starting edge of the tachometer input signal to use for the measurement (rising or falling edge). On the DT9837 module, the starting edge is always the rising edge.
- The value read between measurements (either zero, the default value, or the previous measurement value). On the DT9837 module, this value is always the previous measurement value.

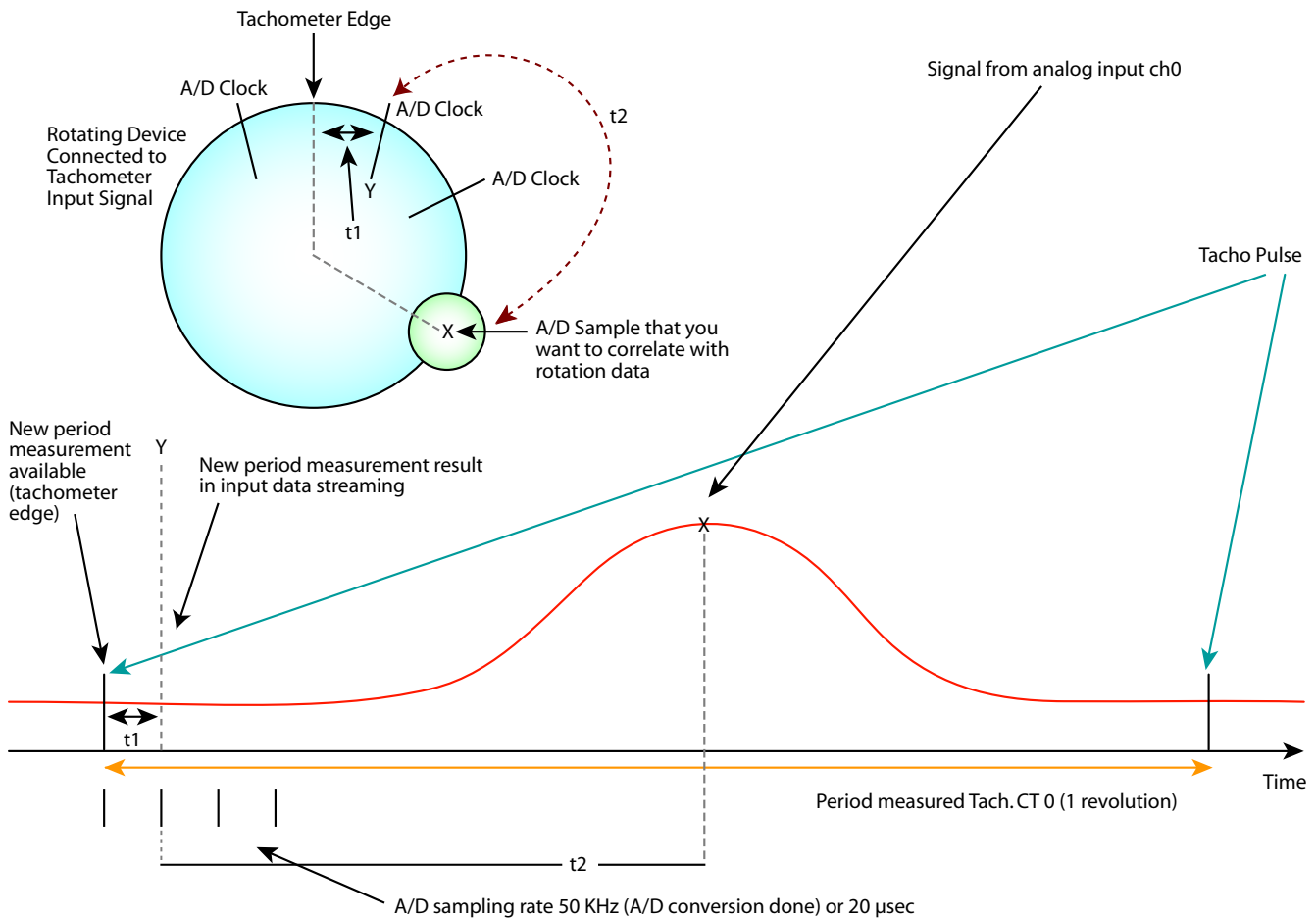

By connecting a rotating device to the tachometer input of the DT9837A, you can measure the frequency or period of the rotating device. The DT9837A also provides the ability to accurately measure the time between the tachometer edge and the next A/D sample or between the A/D sample and the next tachometer edge, so that you can precisely correlate A/D data with rotation data. For example, assume that you want to correlate A/D sample X from analog channel 0 to an angular position of the rotating device. This can be accomplished by using a tachometer signal that always occurs at the top, center position of the rotating device as a reference and measuring the time between the tachometer signal and the next A/D sample (Y). Since you know the frequency of the A/D sample clock (50 kHz, in this case), you know when A/D sample X occurred in relation to A/D sample Y ($t2 = 1/50 \text{ kHz} \times \text{num samples from Y to X}$). By using the Tachometer Counter 1 to measure the time ($t1$) between the tachometer signal and A/D sample Y, you can calculate exactly where A/D sample X occurred in time from the tachometer signal (result = $t1 + t2$). Given the rotation speed of Tachometer Counter 0, you can then calculate the angular position of A/D sample X

- A flag (called Stale) indicating whether or not the data is new. If the Stale flag is set as Used (the default value), the most significant bit (MSB) of the value is set to 0 to indicate new data; reading the value before the measurement is complete returns an MSB of 1. If the Stale flag is set to Not Used, the MSB is always set to 0. On the DT9837 module, the MSB is always 0 (not used).

When the operation is started, the internal 12 MHz counter starts incrementing when it detects the first starting edge of the tachometer input and stops incrementing when it detects the next starting edge of the tachometer input. When the measurement is complete, the counter/timer remains idle until it is read. On the next read, either 0 or the current value of the tachometer input (from the previous measurement operation) is returned depending on the module and the Control Panel settings, described above, and the next operation is started automatically.

The software automatically synchronizes the value of the tachometer input with the analog input measurements, so that all measurements are correlated in time.

Phase Measurements – Tachometer Counter 1

On the DT9837A and DT9837B modules, users can measure the phase of the tachometer input in relation to the A/D sample by reading tachometer counter 1.

An internal 48 MHz clock (with 21 ns resolution) is used to calculate the measurement, which allows you to precisely correlate tachometer measurements with the analog input data.

Gate Input Features

The DT9837A-OEM module provides a 4-pin gate input connector for connecting a TTL gate input signal. The DT9837B module provides a BNC connector for connecting a gate input signal.

Users can read the value of gate counter 2 to measure the time between the following signals:

- Completion of the A/D sample to the rising or falling edge of the gate input signal
- Rising or falling edge of the gate input signal to the rising or falling edge of the gate input signal, which you can use to determine the pulse width of the gate signal
- Rising or falling edge of the gate input signal to the completion of the A/D sample

Analog Output Channels

The DT9837, DT9837A, and DT9837C modules support one 24-bit analog output channel. Note that on the DT9837A module, you can read back the value of the analog output channel through the analog input channel list. The DT9837 and DT9837A modules provide a two-pole, 10 kHz Butterworth filter to prevent noise from interfering with the output signal. The analog output channel powers up to a value of $0\text{ V} \pm 10\text{ mV}$.

The DT9837 and DT9837A can output bipolar output signals in the range of $\pm 10\text{ V}$, with a gain of 1. The DT9837C module can output bipolar output signals in the range of $\pm 3\text{ V}$, with a gain of 1.

The output clock on the DT9837, DT9837A, and DT9837C modules is derived from the USB clock to produce the output clock frequency. On the DT9837 module, the clock frequency is fixed at 46.875 kHz. On the DT9837A module, you can program the clock frequency to value between 10 kHz and 52.734 kHz. On the DT9837C module, you can program the clock frequency to value between 10 kHz and 96.0 kHz.

Output Triggers

The DT9837, DT9837A, and DT9837C modules support the following trigger sources for starting analog output operations:

- Software trigger – A software trigger event occurs when you start the analog output operation in software.
- External digital (TTL) trigger – This trigger source is supported on DT9837A and DT9837C modules. An external digital (TTL) trigger event occurs when the module detects a rising-edge transition on the signal connected to the Ext Trig BNC connector on the module.

- Analog threshold trigger – This trigger source is supported on the DT9837A and DT9837C modules.

For the DT9837A module, an analog threshold trigger event occurs when the signal attached to analog input channel 0 rises above a user-specified threshold value. Using software, specify the trigger source as a positive threshold trigger, the threshold trigger channel as analog input channel 0, and the threshold level as a value between 0.2 V and 9.8 V.

For the DT9837C module, the analog threshold trigger event occurs when the signal attached to a specified analog input channel in the analog input channel list rises above a user-specified threshold value. Any of the analog input channels can be used as the trigger. The threshold value is programmable ($\pm 10\text{ V}$ for a gain of 1 or $\pm 1\text{ V}$ for a gain of 10).

Triggering Acquisition on Multiple Modules

You can start acquisition on multiple modules by connecting all modules to a shared external trigger input. When triggered, the modules start acquiring data at the same time. Using this connection scheme, the measurements of one module may not be synchronous with the measurements of another module due to logic delays in the clocking and USB circuitry.

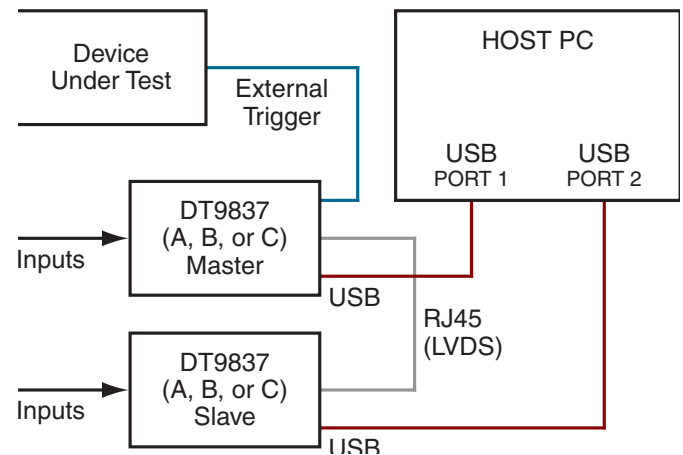

Synchronizing two DT9837 Series modules by daisy chaining the RJ45 connectors (shown using External Trigger).

Synchronizing Acquisition on Multiple DT9837A, DT9837B, or DT9837C Modules

DT9837A, DT9837B, and DT9837C modules provide an RJ45 (LVDS) synchronization connector that you can use to connect and synchronize multiple DT9837A, DT9837B, or DT9837C modules. In this scheme, one module is the master and the other modules are slaves. You specify the synchronization mode (master, slave, or none) of the RJ45 connector using software.

When configured as a master, the RJ45 synchronization connector outputs trigger and clock signals. When configured as a slave, the RJ45 connector accepts trigger and clock signals from the master; you cannot use the Ext Trig BNC connector or the analog threshold trigger on the slave module in this configuration. When configured as none (the default mode), the DT9837A, DT9837B, or DT9837C module uses the USB clock instead of the RJ45 synchronization connector. The synchronization mode remains set until changed or until the application exits.

You can connect multiple modules in one of two ways. The following diagram shows how to connect a maximum of two DT9837A, DT9837B, or DT9837C modules by daisy chaining them together through the RJ45 connector.

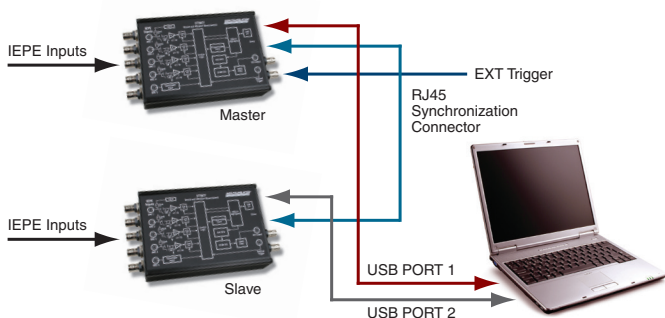

A Master/Slave connection allows two modules to operate in perfect synchronization for 8 IEPE inputs and 2 tachometer inputs.

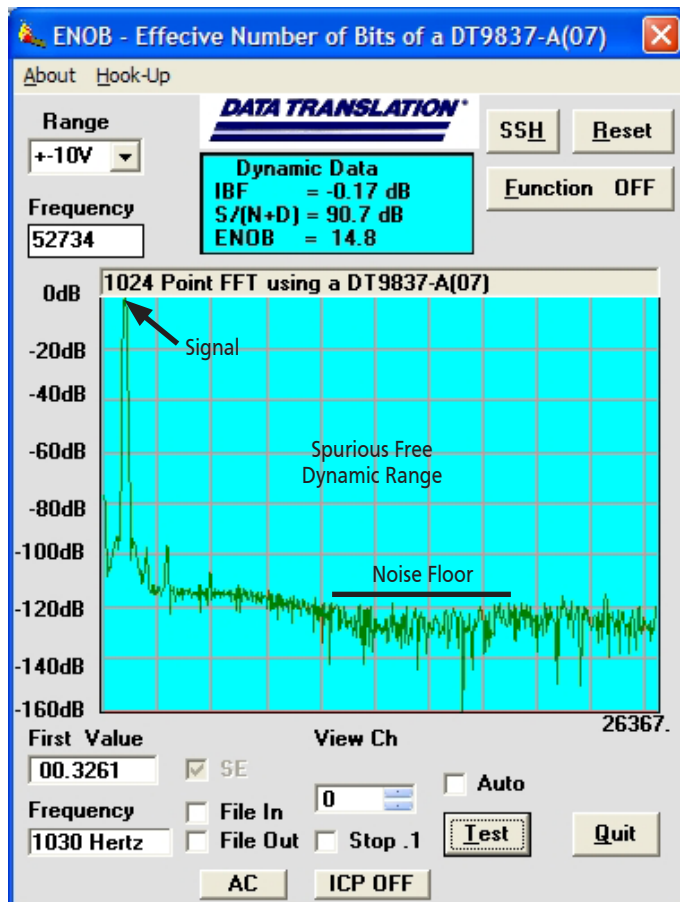

This graph shows the outstanding quality of the DT9837A for all error sources effective number of bits greater than 14.8 from all sources. The ENOBs for all DT9837 Series modules is similar as they use the same ADC and circuitry.

The following diagram shows how to connect a maximum of four DT9837A, DT9837B, or DT9837C modules by using an RJ45 distribution panel, where the panel contains four RJ45 connectors that are wired in parallel.

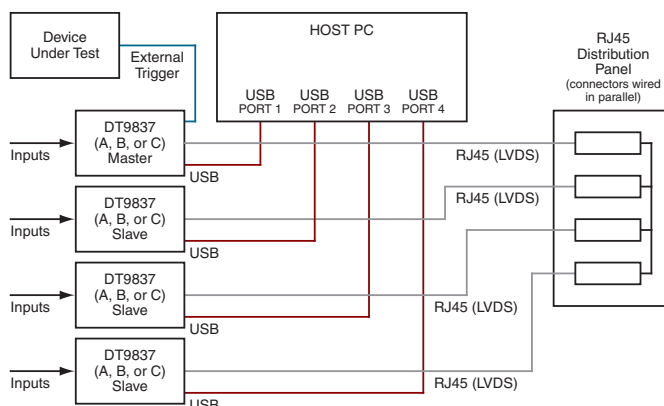

Synchronizing four DT9837 Series modules using an RJ45 distribution panel (shown using External Trigger).

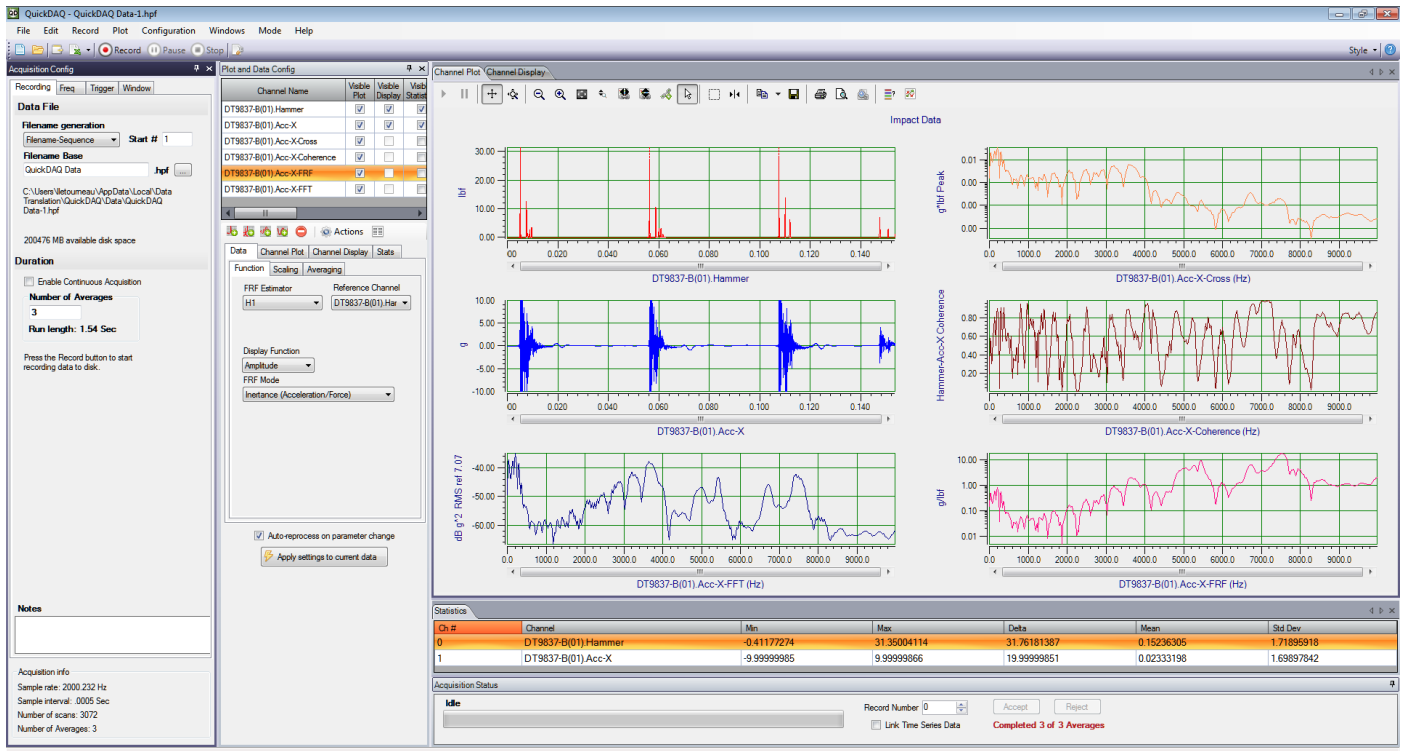

QuickDAQ with Advanced FFT Analysis Option.

When synchronizing multiple modules, start the slave modules before starting the master module. When the master module is triggered (using any of the supported trigger sources), both the master and the slave modules start acquiring data at the same time (within one A/D conversion of the clock). Note that you can set the clock rate to be the same or different on each module. When acquisition is stopped on the master module the slaves continue to run and return data until the analog input subsystem is stopped on the slave modules.

QuickDAQ (Windows only)

If you are using Windows, QuickDAQ allows you to acquire and display from all Data Translation USB and Ethernet data acquisition devices that support analog input streaming. Combine QuickDAQ with Data Translation hardware to acquire data, record data to disk, display the results in both a plot and digital display, and read a recorded data file. Be productive right out of the box with this powerful data logging software. Data can be exported to other applications like Microsoft Excel® and The Mathworks MATLAB® for more advanced analysis. Two additional options can be purchased to add FFT analysis capabilities to the base package.

Key Features

- QuickDAQ Base Package (Free)
 - Ready-to-measure application software
 - Configure, acquire, log, display, and analyze data
 - Customize many aspects of the acquisition, display, and recording functions to suit your needs
- FFT Analysis Option (License Required)
 - Includes all the features of the QuickDAQ Base Package
 - Perform single-channel FFT operations including:
 - ◇ Auto Spectrum
 - ◇ Spectrum
 - ◇ Power Spectral Density
 - Configure and view dynamic performance statistics
 - Supports Hanning, Hamming, Bartlett, Blackman, Blackman Harris, and Flat Top response windows
- Advanced FFT Analysis Option (License Required)
 - Includes all the features of the QuickDAQ Base Package and FFT Analysis Package
 - Perform 2-channel FFT operations including:
 - ◇ FRF
 - ◇ Cross-Spectrum
 - ◇ Cross Power Spectral Density
 - ◇ Coherence
 - ◇ Coherent Output Power
 - Supports real, imaginary, and Nyquist display functions
 - Additional FFT analysis functions supported: Exponential, Force, Cosiner Taper
 - Save data to .uff file format

Other Software Options

Windows Software

The following software is available for use with this module:

- **Device Driver** – The device driver allows you to use the DAQ module with any of the supported software packages or utilities.
- **Calibration Utility** – This utility allows you to calibrate features of the DAQ module.
- **DT-Open Layers® for .NET Class Library** – Use this class library if you want to use Visual C#® or Visual Basic® for .NET to develop application software using Visual Studio® 2003-2012; the class library complies with the DT-Open Layers standard.
- **DataAcq SDK** – Use the DataAcq SDK to use Visual Studio 6.0 and Microsoft® C or C++ to develop application software using Windows 10/8/7/Vista/XP 32/64-bit; the DataAcq SDK complies with the DT-Open Layers standard.
- **DAQ Adaptor for MATLAB** – Data Translation's DAQ Adaptor provides an interface between the MATLAB® Data Acquisition (DAQ) toolbox from The MathWorks™ and Data Translation's DT-Open Layers architecture.
- **LV-Link** – Data Translation's LV-Link is a library of VIs that enable LabVIEW™ programmers to access the data acquisition features of DT-Open Layers compliant USB and PCI devices.

Linux Software

- **UL for Linux** – Use this Library to develop applications in C, C++, and Python on Linux (supported by DT9837A, DT9837B, and DT937C modules only).

Technical Support

Application engineers are available by phone and email during normal business hours to discuss your application requirements. Extensive product information, including drivers, example code, pinouts, a searchable Knowledge Base, and much more, is available 24 hours a day on our web site at www.mccdaq.com/Support.aspx.

Ordering Summary

HARDWARE

- DT9837
- DT9837-OEM
- DT9837A
- DT9837A-OEM
- DT9837B
- DT9837B-OEM
- DT9837C-BNC

ACCESSORIES

- BNC DIN Rail Kit
- EP386

FREE WINDOWS SOFTWARE

- QuickDAQ
- DAQ Adaptor for MATLAB
- LV-Link

OPTIONAL WINDOWS SOFTWARE

- QuickDAQ FFT Analysis Option (License Required)
- QuickDAQ Advanced FFT Analysis Option (License Required)

FREE LINUX SOFTWARE

- UL for Linux (supported by DT9837A, DT9837B, and DT937C modules only)