

## Product Datasheet - Technical Specifications



More information in our Web-Shop at ► [www.meilhaus.com](http://www.meilhaus.com)

### Your contact

Technical and commercial sales, price information,  
quotations, demo/test equipment, consulting:

Tel.: +49 - (0)81 41 - 52 71-0

E-Mail: [sales@meilhaus.com](mailto:sales@meilhaus.com)

**Meilhaus Electronic GmbH**  
Am Sonnenlicht 2  
82239 Alling/Germany

Tel. +49 - (0)81 41 - 52 71-0 E-  
Mail [sales@meilhaus.com](mailto:sales@meilhaus.com)

Mentioned company and product names may be registered trademarks of the respective companies. Errors and omissions excepted. © Meilhaus Electronic.

# ECONseries

## Low Cost USB Data Acquisition Modules

### Overview

The ECONseries is a flexible yet economical series of multifunction DAQ modules. You choose the number of analog I/O and digital I/O channels, the resolution you need, and the signal range of your application.

### Key Features

- Ultimate flexibility with up to 24 analog inputs, 2 analog outputs, 28 digital I/O, and one 32-bit counter timer
- 10-, 12-, or 16-bit resolution
- Independent subsystem operation at sample rates up to 750 kS/s per channel
- Simultaneous analog inputs on the DT9816 modules
- Signal range of  $\pm 10$  V on both the analog input and analog output
- Generate sine, rectangle, triangle, or DC waveforms with the analog outputs
- Three versions of digital I/O modules: isolated, non-isolated, and high current drive
- Monitor and control up to 28 digital I/O lines
- Perform event counting, frequency measurement, edge-to-edge measurement, and rate generation
- Shielded, rugged enclosure for noise immunity, with built-in screw terminals
- Easy signal connections on the DT9812-10V-OEM with two 20-pin connectors for all I/O signals
- All modules run off USB power supply, no external power supply needed
- Includes free QuickDAQ software to get up and running quickly (does not support DIO)

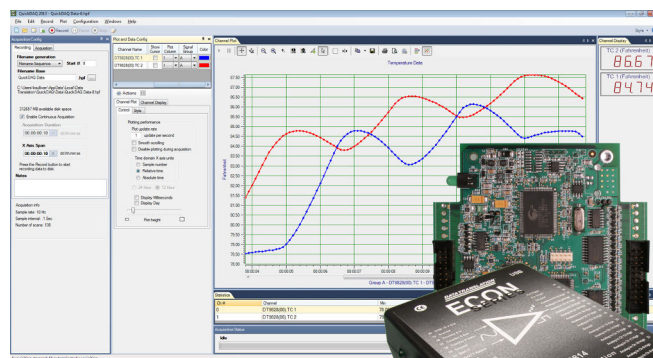

*The ECONseries provides economical, multifunction data acquisition instruments for the USB bus. Simply install the software, connect your module to any USB port, and measure.*



### Supported Operating Systems

- Windows® 10/8/7/Vista®/XP 32/64-bit

### Analog Inputs

The DT9810 provides 10-bit resolution, while the DT9812, DT9813, and DT9814 modules provide 12-bit resolution. For maximum resolution, the DT9816 modules provide 16-bit resolution.

The DT9810 and DT9812 modules provide eight single-ended (SE) analog input channels. The DT9813 modules provide 16 single-ended analog inputs. The DT9814 modules provide 24 single-ended analog input channels. The modules can acquire data from a single analog input channel or from a group of analog input channels.

Module	Analog Inputs	Resolution	I/O Range	Analog Input Sample Rate	Analog Outputs	Analog Output Update Rate	Digital I/O	Counter/Timer
DT9810	8 SE	10-bit	0 V to 2.44 V	25 kS/s aggregate	—	—	20 I/O	1
DT9812-10V	8 SE	12-bit	$\pm 10$ V, $\pm 5$ V, $\pm 2.5$ V, $\pm 1.25$ V	50 kS/s aggregate	2	50 kS/s	8 in/8 out	1
DT9812A	8 SE	12-bit	$\pm 10$ V, $\pm 5$ V, $\pm 2.5$ V, $\pm 1.25$ V	100 kS/s aggregate	2	75 kS/s	8 in/8 out	1
DT9813-10V	16 SE	12-bit	$\pm 10$ V, $\pm 5$ V, $\pm 2.5$ V, $\pm 1.25$ V	50 kS/s aggregate	2	50 kS/s	4 in/4 out	1
DT9813A	16 SE	12-bit	$\pm 10$ V, $\pm 5$ V, $\pm 2.5$ V, $\pm 1.25$ V	100 kS/s aggregate	2	75 kS/s	4 in/4 out	1
DT9814-10V	24 SE	12-bit	$\pm 10$ V, $\pm 5$ V, $\pm 2.5$ V, $\pm 1.25$ V	50 kS/s aggregate	2	50 kS/s	—	1
DT9816	6 SE	16-bit	$\pm 10$ V or $\pm 5$ V	50 kS/s per ch	—	—	8 in/8 out	1
DT9816-A	6 SE	16-bit	$\pm 10$ V or $\pm 5$ V	150 kS/s per ch	—	—	8 in/8 out	1
DT9816-S	6 SE	16-bit	$\pm 10$ V or $\pm 5$ V	750 kS/s per ch	—	—	8 in/8 out	1
DT9817-H	—	—	—	—	—	—	28 I/O high drive	1
DT9817-R	—	—	—	—	—	—	8 in/8 out Isolated high drive	1

# DT9812

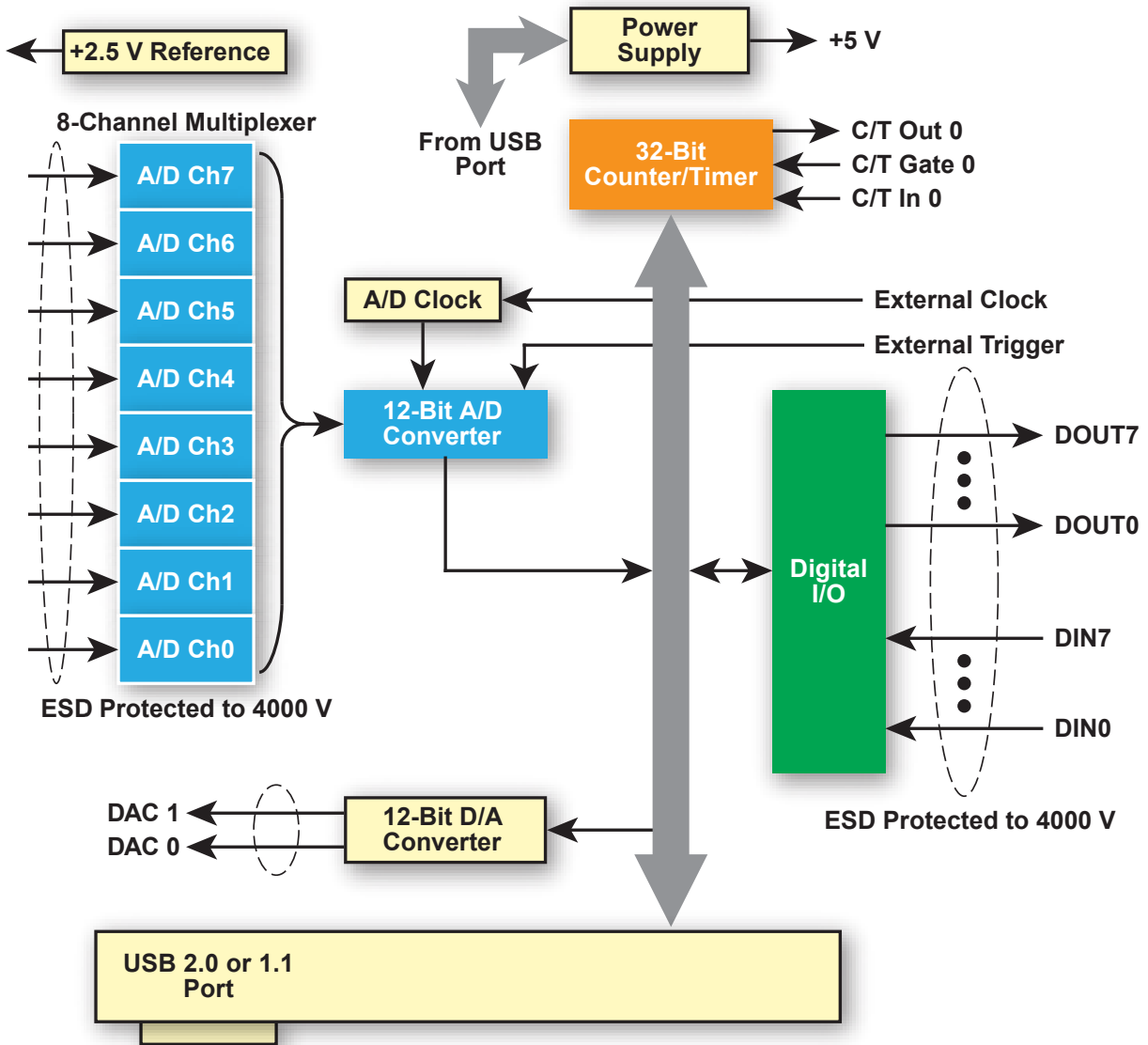

Block Diagram of the DT9812-10V, DT9812-10V-OEM, and DT9812A Modules.



DT9812-10V

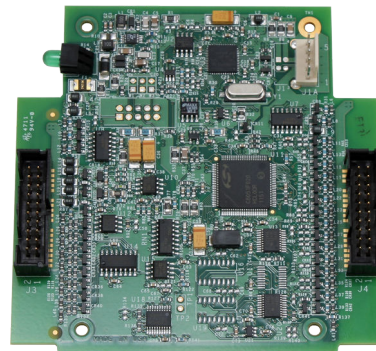

DT9812-10V-OEM

All DT9812 versions provide 8 analog inputs with 12-bit resolution, 2 analog outputs, 16 digital I/O, and 1 counter/timer.

# DT9816

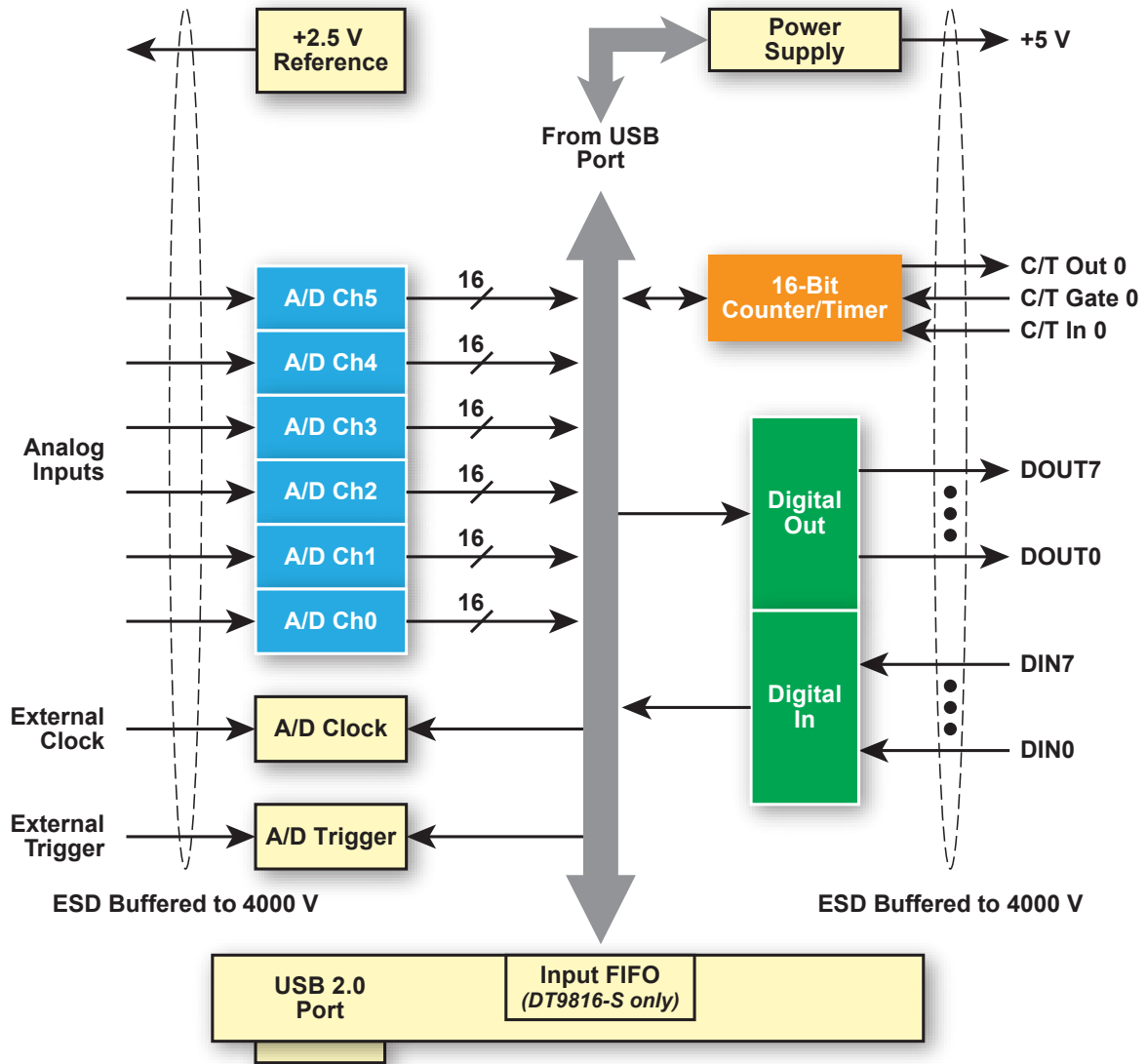

Block Diagram of the DT9816 Series Modules.



DT9816

The DT9816 provides 6 simultaneous analog inputs with 16-bit resolution, 16 digital I/O, and 1 counter/timer.



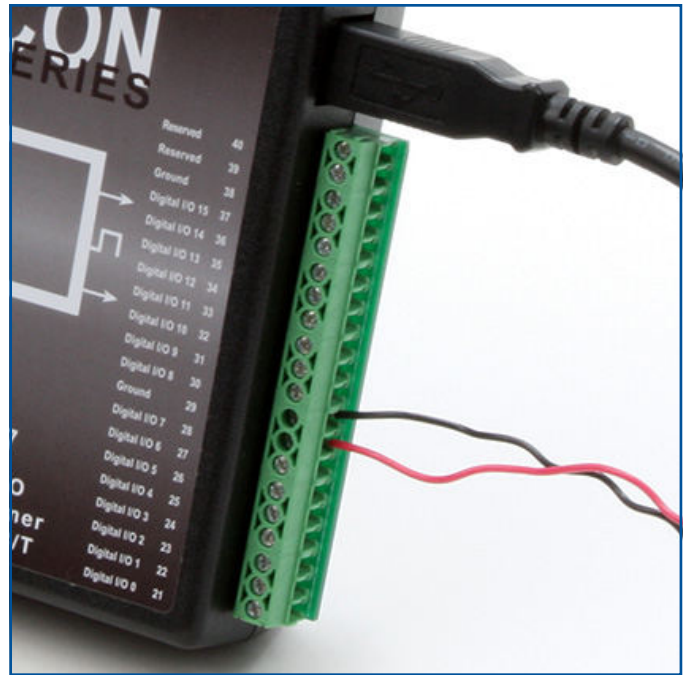

Connect to a host computer using the standard USB 1.1 or 2.0 plug-in connector on the ECONseries module. The USB connector provides power to the module, eliminating the need for an external power supply, while providing complete enumeration for all data flow.

Connect sensors directly to the screw terminal of the module. Screw terminals can accept AWG 26 to AWG 16 size wire.

### Easy to Connect

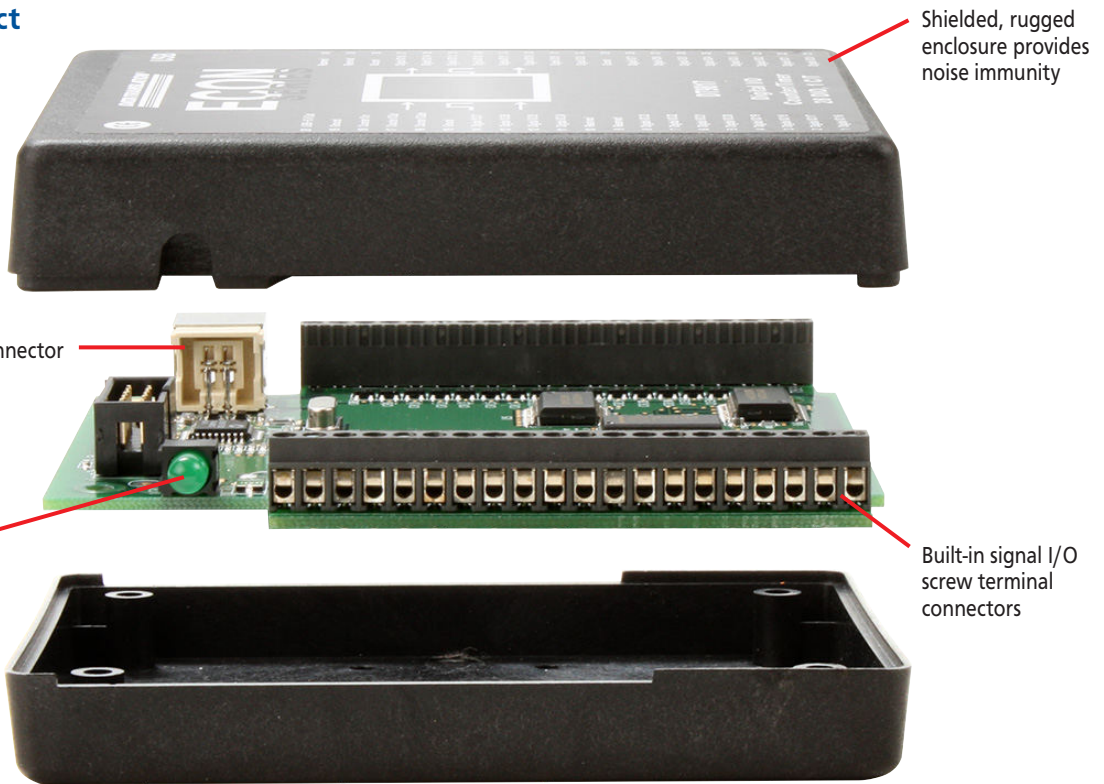

Shielded, rugged enclosure provides noise immunity

Standard USB Connector

LED indicator provides USB status

Built-in signal I/O screw terminal connectors

All ECONseries modules provide easy signal and USB connections in a shielded, rugged enclosure.

# ECONseries Design Advantages

## Prevents Measurement Errors

$\frac{R_1 + R_2}{R_1} = \text{Input Error}$

OTHER MODULES	ECONseries
$\frac{R_1 + R_2}{R_1} = \frac{144k + 1K\Omega}{144K\Omega} = 0.69\% \text{ error}$	$\frac{R_1 + R_2}{R_1} = \frac{10M + 1K\Omega}{10M\Omega} = \text{Virtually 0 error}$

The ECONseries provides 10 MΩ of input impedance for virtually error-free analog input measurements.

## Operates Reliably

Electro-Static Discharge ESD protection up to 8000 V

4000 V Touch and 8000 V Gap ESD Protection

The ECONseries provides 4000 V touch and 8000 V gap ESD protection circuitry for superior noise immunity.

## Performs Simultaneous Operations

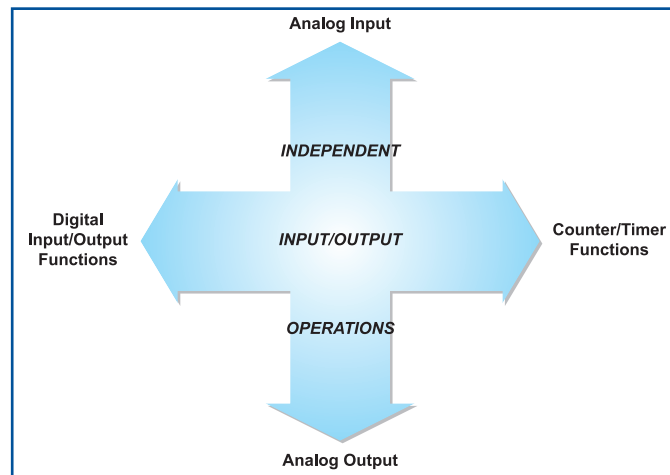

All I/O functions of the ECONseries are independent and are performed simultaneously.

## Prevents Measurement Errors

Built-in Waveform Generator for generating sine, ramp, triangle, square wave, and DC signals.

The DT9812-10V, DT9813-10V, and the DT9814-10V modules provide 2 waveform DACs for generating sine, ramp, triangle, square wave, and DC signals.

## Detects Edges for Pulse Width, Frequency, and Period Measurements

Program the edge to start the measurement (rising shown here)      Program the edge to stop the measurement (falling shown here)

Connect Signal to C/T Gate 0

The interval is calculated and the count is returned.

Pulse width =  $\frac{\text{\# of counts}}{24 \text{ MHz}}$

Frequency =  $\frac{24 \text{ MHz}}{\text{\# of counts}}$

Period =  $\frac{1}{\text{Frequency}}$

Programmable edges allow you to use the counter/timer of an ECONseries module to measure the pulse width, frequency, and period of a signal.

## DT9816 Design Advantages

### Six Simultaneously Sampled Analog Inputs

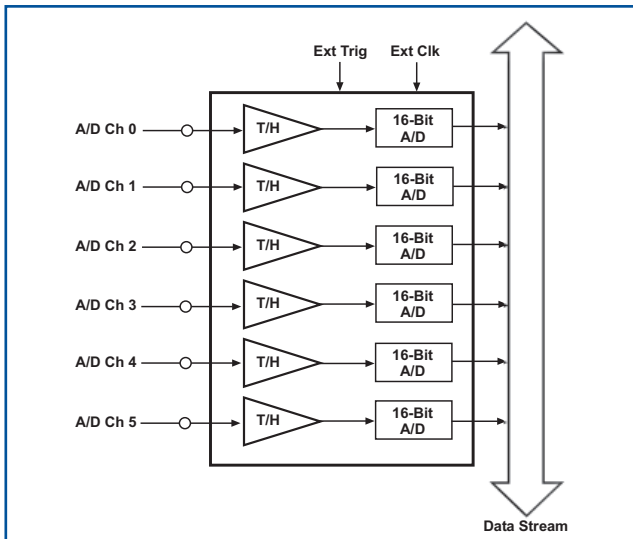

The DT9816 modules feature six, independent, successive-approximation A/D converters with track-and-hold circuitry. Each converter uses a common clock and trigger for simultaneous sampling of all six analog input signals. The throughput rate varies depending on the model you choose.

### Accurate Measurements Designed In

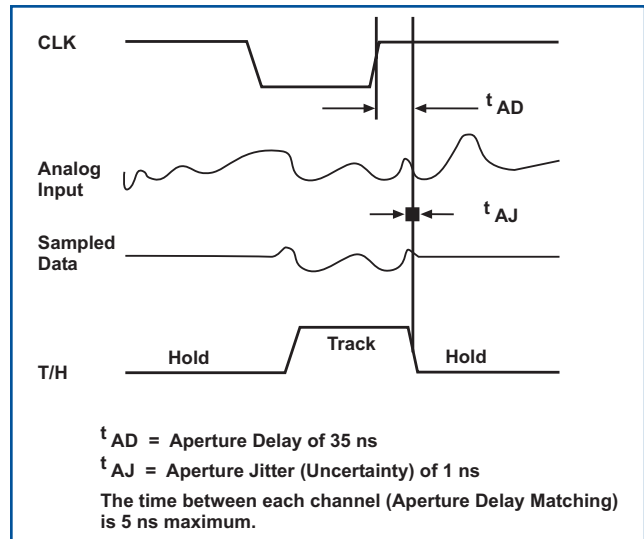

The A/D design of the DT9816 modules feature built-in accuracy. A maximum aperture delay of 35 ns (the time that it takes the A/D to switch from track to hold mode) is well matched at 5 ns across all six track-and-hold circuits, virtually eliminating the channel-to-channel skew that is associated with multiplexed inputs. A maximum aperture uncertainty of 1 ns (the jitter or variance in aperture delay), virtually eliminates phase noise in your data.

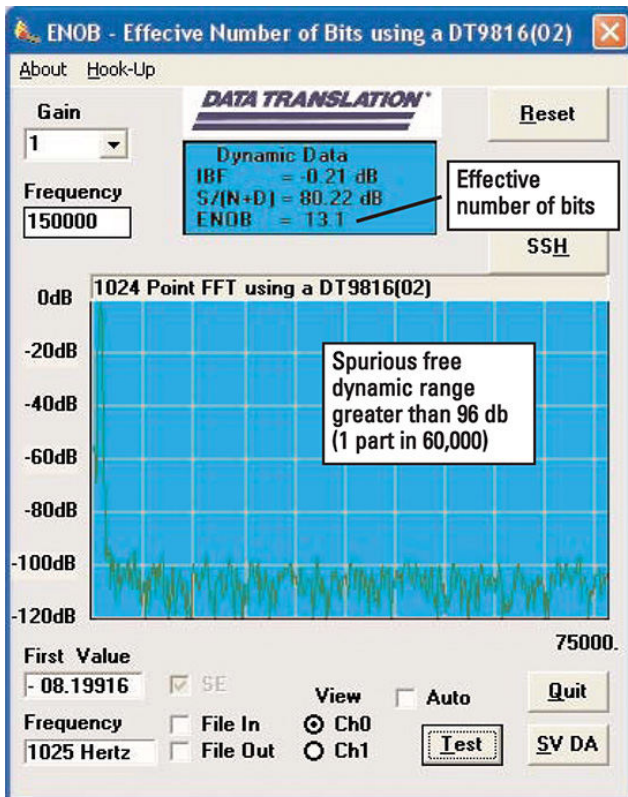

This graph shows the outstanding quality of the DT9816-A for all error sources – effective number of bits greater than 13.1 from all sources. Note the absence of harmonic content and digital switching noise across the full spectrum.

## Key Features of the DT9816

- **High-Speed Simultaneous Acquisition** – Acquire all six analog input channels simultaneously at up to 50 kS/s per channel (DT9816), 150 kS/s per channel (DT9816-A), or 750 kS/s per channel (DT9816-S).
- **Input -3 dB bandwidth is 4 MHz typical** (DT9816, DT9816-A), 40 MHz typical (DT9816-S)
- **High-Resolution Data** – 16-bit resolution for precision measurements.
- **Two Bipolar Input Ranges** – Input range of  $\pm 10$  V and  $\pm 5$  V signal for maximum flexibility.
- **Digital I/O Functions** – 8 digital inputs and 8 digital outputs for controlling external equipment.
- **Multifunction Counter/Timer** – One 16-bit counter/timer for event counting, frequency measurement, and continuous pulse output operations.

DT9810 modules feature a full-scale input signal range of 0 to 2.44 V. If you need a full-scale input signal range of  $\pm 10$  V, the DT9812, DT9813, DT9814, and DT9816 modules are available. The DT9816 modules also feature a full-scale input signal range of  $\pm 5$  V.

The DT9812, DT9813, and DT9814 modules provide programmable gains of 1, 2, 4, and 8; and the DT9816 modules provide gains of 1 and 2.

Effective Input Range		
Module	Gain	Bipolar Input Range
DT9812-10V DT9812A	1	$\pm 10$ V
DT9813-10V DT9813A	2	$\pm 5$ V
DT9814-10V	4	$\pm 2.5$ V
	8	$\pm 1.25$ V
DT9816 DT9816-A	1	$\pm 10$ V
DT9816-S	2	$\pm 5$ V

## Throughput

Before selecting a module, consider the pros and cons of the analog input architecture and what kind of throughput you need.

Modules with multiplexed inputs, such as the DT9810, DT9812, DT9813, and DT9814 modules provide only one A/D converter that is shared by the inputs. A multiplexer selects or switches the channel to acquire, which introduces a settling time and phase shift between channels. In a multiplexed architecture, the total or aggregate throughput is the maximum rate of the sample clock. The DT9810 provides an aggregate sample rate of up to 25 kS/s, while the DT9812-10V, DT9813-10V, and DT9814-10V provide an aggregate sample rate of up to 50 kS/s, and the DT9812A and DT9813A provide an aggregate throughput of up to 100 kS/s. The per channel rate is determined by dividing the maximum sample rate by the number of inputs sampled. For example, if you are acquiring 8 inputs on a DT9812-10V, the per channel rate is 6.25 kS/s.

In contrast, modules that provide separate A/D converters per channel, such as the DT9816, DT9816-A, and DT9816-S, eliminate the phase shift between signals, allowing you to correlate simultaneous measurements of multiple inputs. The per channel sample rate, in this case, is the maximum rate of the sample clock (50 kS/s for the DT9816, 150 kS/s for the DT9816-A, and 750 kS/s for the DT9816-S). The aggregate total throughput is the number of channels times the per channel throughput.

## Input Triggers

A trigger is an event that occurs based on a specified set of conditions. Acquisition starts when the module detects the initial trigger event and stops when the buffers on the queue have been filled or when you stop the operation.

The DT9812, DT9813, DT9814, and DT9816 Series modules support the following trigger sources:

- Software trigger
- External digital (TTL) trigger

## Analog Outputs

DT9812, DT9813, and DT9814 Series modules provide two 12-bit analog output channels (DACs). The modules can output data from a single analog output channel or from both analog output channels.

The DT9812-10V, DT9812-10V-OEM, DT9812A, DT9813-10V, DT9813A and DT9814-10V modules provide a fixed output range of  $\pm 10$  V.

## Output Trigger

A trigger is an event that occurs based on a specified set of conditions. The DT9812, DT9813, and DT9814 Series modules support a software trigger for starting analog output operations. Using a software trigger, the module starts outputting data when it receives a software command.

## Waveform Generation

Generate sine, rectangle, triangle, or DC waveforms from one or both analog output channels. You can select the frequency, amplitude, duty, and offset cycle of the signal. For the DT9812-10V, DT9812-10V-OEM, DT9813-10V, DT9814-10V, the output frequency ranges between 30 Hz and 50 kHz. For the DT9812A and DT9813A, the output frequency ranges between 30 Hz and 75 kHz.

## Digital I/O Lines

The DT9812 Series modules provide 8 dedicated digital input lines and 8 dedicated digital output lines. The DT9813 Series modules provide 4 dedicated digital input lines and 4 dedicated digital output lines. The DT9814 Series modules do not support digital I/O operations. The DT9812-10V, DT9816, DT9816-A, and DT9816-S modules feature 8 digital input lines and 8 digital output lines. The DT9813-10V provides 4 digital input lines, and 4 digital output lines.

The DT9810 module provides 20 programmable digital I/O lines. If you need more digital I/O lines and do not need analog I/O functionality, select the DT9817-H module, which provides 28 programmable digital I/O lines. The DT9810 can source 4.5 mA and sink 10 mA. The DT9817-H provides high-drive capability, and can source 15 mA and sink 64 mA.



The DT9817-R can switch up to 30 V at 400 mA. It features 8 dedicated digital input lines and 8 dedicated digital output lines. This module includes channel-to-channel isolation of up to 500 V (250 V between digital input channels that are paired in an opto-isolator). The DT9817-H and DT9817-R are ideal for solid state or mechanical relays.

### Multifunction Counter/Timers

The DT9816 modules support one 16-bit counter/timer channel. All other modules feature one 32-bit counter/timer (16 bits in rate generation mode). The counter accepts a counter/timer clock input signal (pulse input signal) and gate input signal, and outputs a pulse signal (clock output signal). You can perform event counting, frequency measurement, edge-to-edge measurement (not supported by DT9816 modules), and rate generation (continuous pulse output) operations using this counter/timer.

### Synchronizing Multiple Modules

You can synchronize the analog input operations of multiple DT9812, DT9813, DT9814, and DT9816 Series modules by connecting the output of the counter/timer from one module to the clock input of the next module as shown in the diagram on the right.

### Easy Signal Connections

Built-in screw terminals on the module allow easy and direct signal connections. No extra accessories are required. Simply wire your signals to the module and you're all set. For OEM users, the board-only versions of the DT9812-10V-OEM provides two, 20-pin connectors to accommodate all I/O signals.

### Cross-Series Compatibility

Virtually all Data Translation data acquisition modules are compatible with the DT-Open Layers® software standard. This means any application developed with one of Data Translation's software products can easily be upgraded to a new Data Translation module with little to no reprogramming needed.

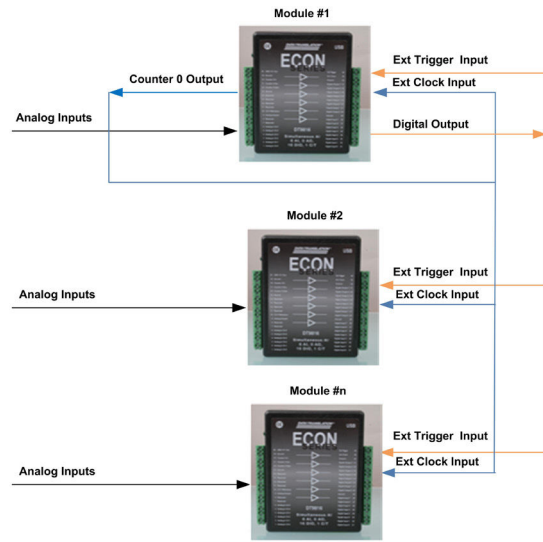

*You can synchronize the analog I/O operations of multiple modules by connecting them together.*

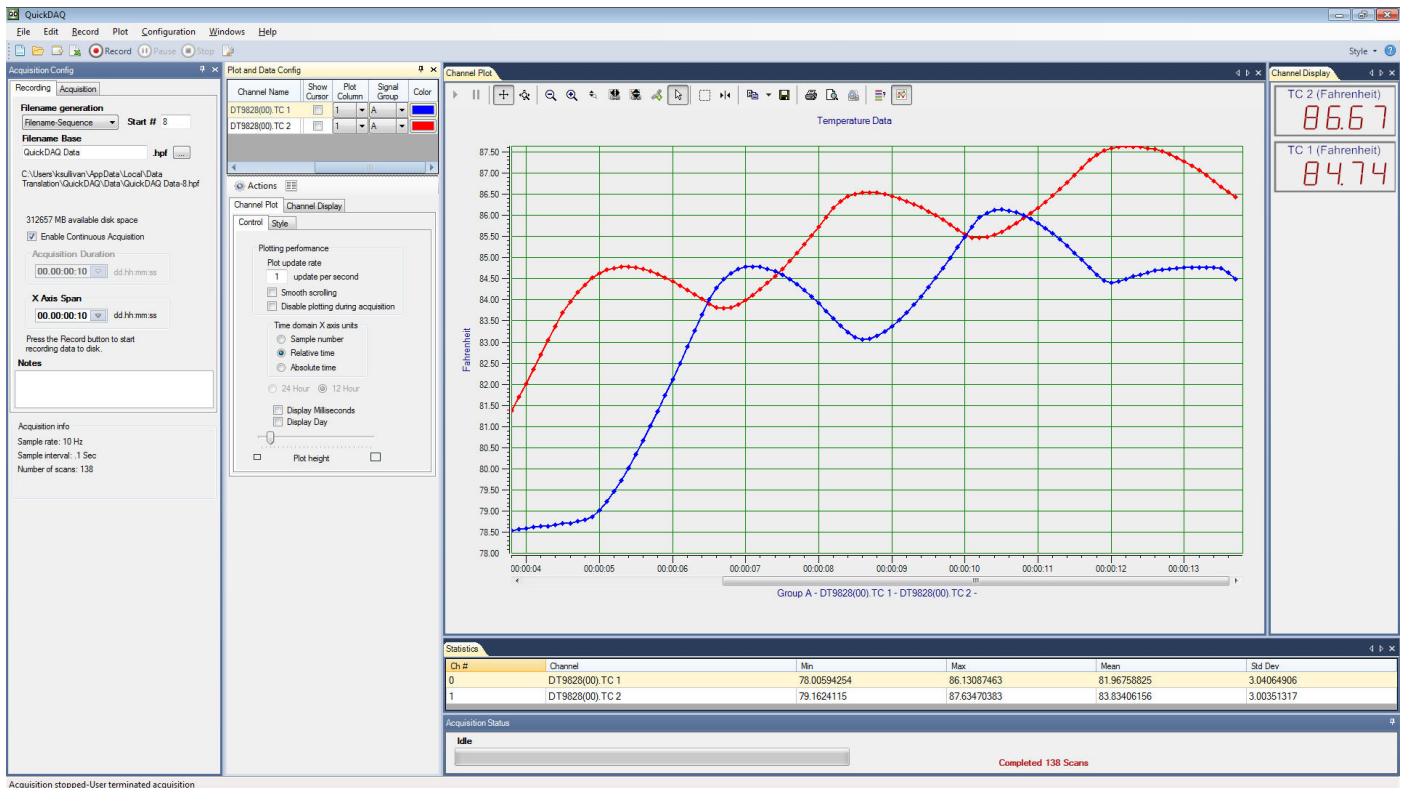

**QuickDAQ ships free-of-charge and allows you to get up and running quickly.**

## QuickDAQ

QuickDAQ allows you to acquire and display from all Data Translation USB and Ethernet data acquisition devices that support analog input streaming. Combine QuickDAQ with Data Translation hardware to acquire data, record data to disk, display the results in both a plot and digital display, and read a recorded data file. Be productive right out of the box with this powerful data logging software. Data can be exported to other applications like Microsoft Excel® and The Mathworks MATLAB® for more advanced analysis. Two additional options can be purchased to add FFT analysis capabilities to the base package.

### Key Features

- **QuickDAQ Base Package (Free)**
  - Ready-to-measure application software
  - Configure, acquire, log, display, and analyze your data
  - Customize many aspects of the acquisition, display, and recording functions to suit your needs

- **FFT Analysis Option (License Required)**
  - Includes all the features of the QuickDAQ Base Package
  - Perform single-channel FFT operations including:
    - ◇ Auto Spectrum
    - ◇ Spectrum
    - ◇ Power Spectral Density
  - Configure and view dynamic performance statistics
  - Supports Hanning, Hamming, Bartlett, Blackman, Blackman Harris, and Flat Top response windows
- **Advanced FFT Analysis Option (License Required)**
  - Includes all the features of the QuickDAQ Base Package and FFT Analysis Package
  - Perform 2-channel FFT operations including:
    - ◇ FRF
    - ◇ Cross-Spectrum
    - ◇ Cross Power Spectral Density
    - ◇ Coherence
    - ◇ Coherent Output Power
  - Supports real, imaginary, and Nyquist display functions
  - Additional FFT analysis functions supported: Exponential, Force, Cosiner Taper
  - Save data to .uff file format

## Other Software Options

There are many software choices available for application development, from ready-to-measure applications to programming environments.

The following software is available for use with an ECONseries module and is provided on the Data Acquisition Omni CD:

- **ECONseries Device Driver** – The device driver allows you to use an ECONseries module with any of the supported software packages or utilities.
- **ECONseries Calibration Utility** – This utility allows you to calibrate features of an ECONseries module.
- **Quick DataAcq** application – The Quick DataAcq application provides a quick way to get up and running. Using this application, verify key features of the module, display data on the screen, and save data to disk.
- **DT-Open Layers® for .NET Class Library** – Use this class library if you want to use Visual C#® or Visual Basic® for .NET to develop application software using Visual Studio® 2003-2012; the class library complies with the DT-Open Layers standard.
- **DataAcq SDK** – Use the DataAcq SDK to use Visual Studio 6.0 and Microsoft® C or C++ to develop application software using Windows 10/8/7/Vista/XP 32/64-bit; the DataAcq SDK complies with the DT-Open Layers standard.
- **DAQ Adaptor for MATLAB** – Data Translation's DAQ Adaptor provides an interface between the MATLAB® Data Acquisition (DAQ) toolbox from The MathWorks™ and Data Translation's DT-Open Layers architecture.
- **LV-Link** – Data Translation's LV-Link is a library of VIs that enable LabVIEW™ programmers to access the data acquisition features of DT-Open Layers compliant USB and PCI devices.

## Ordering Summary

### MODULES

- DT9810
- DT9812-10V
- DT9812-10V-OEM
- DT9812A
- DT9813-10 V
- DT9813A
- DT9814-10V
- DT9816
- DT9816-A
- DT9816-S
- DT9817-H
- DT9817-R

### ACCESSORIES

- DIN Rail Kit

### FREE SOFTWARE

- QuickDAQ
- **DAQ Adaptor for MATLAB** – Access the analysis and visualization tools of MATLAB®.
- **LV-Link** – Access the power of Data Translation boards through LabVIEW™.

### OPTIONAL SOFTWARE

- QuickDAQ FFT Analysis Option (License Required)
- QuickDAQ Advanced FFT Analysis Option (License Required)