

Product Datasheet - Technical Specifications



More information in our Web-Shop at ► www.meilhaus.com

Your contact

Technical and commercial sales, price information,
quotations, demo/test equipment, consulting:

Tel.: **+49 - (0)81 41 - 52 71-0**

FAX: **+49 - (0)81 41 - 52 71-129**

E-Mail: sales@meilhaus.com

Meilhaus Electronic GmbH
Am Sonnenlicht 2
82239 Alling/Germany

Tel. **+49 - (0)81 41 - 52 71-0**
Fax **+49 - (0)81 41 - 52 71-129**
E-Mail sales@meilhaus.com

Mentioned company and product names may be registered trademarks of the respective companies. Errors and omissions excepted. © Meilhaus Electronic.

Keysight Technologies

84904/5/8M Programmable Step Attenuators for Microwave and RF Manufacturing Test Systems

Product Overview

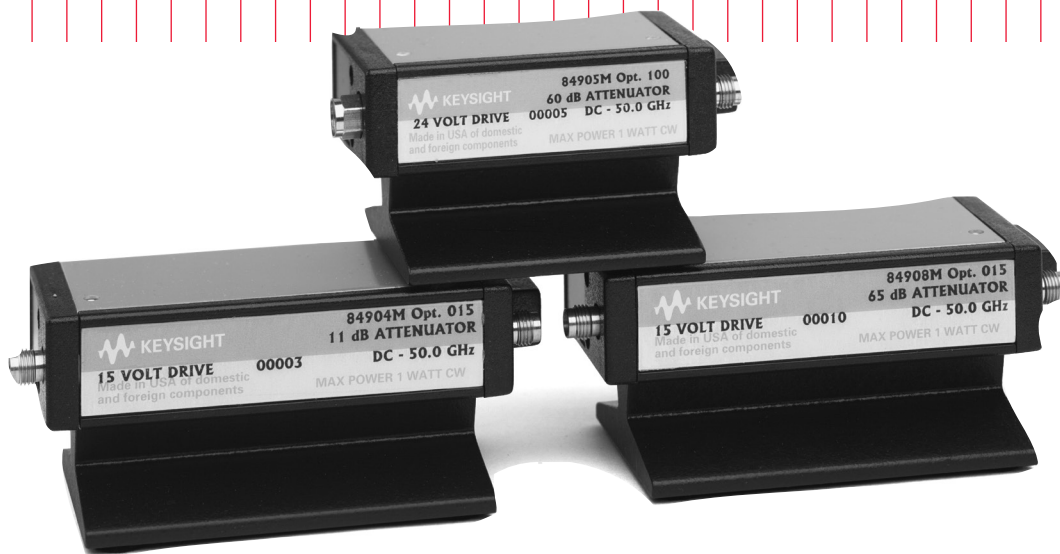

Features and description

- Excellent repeatability: <0.03dB typical
- Low insertion loss: <2.6 dB @ 50 GHz (84905M)
- Long life: >2 million cycles
- DC to 50 GHz frequency coverage
- Optional calibration data
- 0 to 11 dB, 0 to 60 dB, 0 to 65 dB
- 1 dB steps, 10 dB steps, 5 dB steps respectively
- High accuracy
- Excellent reliability

In today's fast moving technical industries, test engineers need components they can count on. Keysight Technologies, Inc. now offers an extension to its existing attenuators that combine its legendary reliability with a higher frequency (50 GHz) capability.

Increase frequency

For test systems that require increased frequency capability (50 GHz) with variable attenuation ranges and steps the M family of attenuators has a solution that fits your need. Options include:

- 84904M: 0 to 11 dB in 1 dB steps (4 section)
- 84905M: 0 to 60 dB in 10 dB steps (3 section)
- 84908M: 0 to 65 dB in 5 dB steps (4 section)

Reduce downtime

Keysight is the world leader in innovating and developing microwave accessories for communications and aerospace applications. Our innovative design and strict adherence to quality process control ensure that each attenuator is guaranteed to perform within warranted specifications for its entire lifetime. With fewer breakdowns and less need to recalibrate, your test platform performs better with less downtime, creating more throughput and revenue.

Raise your standards

All Keysight attenuators offer excellent repeatability and long life – up to five times the lifecycles of the competition. Along with our aggressive specifications for SWR, and insertion loss, you have an attenuator that will exceed the expectations of even the most demanding engineer with its precision and durability.

Increase productivity

When you buy your attenuators from Keysight, you will notice a difference. Your test platforms will run smoother, longer, and faster, while yielding more viable and valuable measurements.

Description

These attenuators offer repeatability of better than 0.03 dB and excellent life (greater than 2 million switching cycles per section).

The M family of programmable step attenuators offers coaxial measurements to 50 GHz in a compact rugged design. The first model is the Keysight 84904M, which offers outstanding performance with an attenuation range of 0 to 11 dB in 1 dB steps. The next, high frequency model, is the Keysight 84905M, which provides a range from 0 to 60 dB in 10 dB steps. Last, the Keysight 84908M provides an attenuation range from 0 to 65 dB in 5 dB steps.

Keysight's design, seen in the 84904/6/7K and L attenuators, sets the standard for size and performance. High attenuation accuracy and low SWR are achieved through the use of miniature thin-film attenuation cards. Insertion loss performance is outstanding, with less than 3.0 dB of loss at 50 GHz. Their compact design allows for easy integration into instruments and ATE systems.

For operating to 50 GHz the 84904/5/8M models offer the 2.4 mm connector that is the best solution for top performance as well as rugged

and repeatable connections. Each model in the 84904/5/8M family comes with two female connectors (Option 101) or may be ordered with one female and one male connector for easy insertion into a microwave chain (Option 100).

Individual calibration data reports of attenuation and SWR are available. This data, measured with a Keysight automatic network analyzer, can be ordered as Option UK6.

Attenuation switching and control

These units feature the same small solenoids and switching circuits as the Keysight 8494/5/6/7 step attenuator family. Switching time is a maximum of 20 milliseconds; this includes contact settling time. Once switched, the units are latched with permanent magnets, capable of withstanding shocks over 10 Gs. The solenoids automatically disconnect after switching, which minimizes the attenuators' power requirements and simplifies the driver circuit design. Solenoids are available in either 24 volt (Option 024), 15 volt (Option 015), and 5 volt (Option 011) ranges to fit your instrument or system requirements.

The units come equipped with 10-pin DIP headers for connecting DC control lines. Available accessories include a 203 mm (8 inch) or 406 mm (16 inch) ribbon cable (11764-60002 or 11764-60003, respectively) with DIP-type connectors that are compatible with standard 14-pin DIP IC sockets. Alternately, a 1524 mm (5 foot) cable (11764-60001) with free wires for direct soldering, or a 1524 mm (5 foot) drive cable that connects to the 11713A attenuator/switch driver, allowing for easy integration into GPIB-controlled automatic test systems (11764-60004) may be ordered.

Selection switching

Figure 2 shows one attenuator section schematic. Each section utilizes one solenoid with dual coil windings, one coil to switch in the attenuator card (e.g. 10 dB) and one coil to switch in the thru line (0 dB).

With positive voltage applied to the common pin, the state (attenuator card or thru line) of a particular section is driven by connecting its attenuator card pin or thru pin to a negative voltage or ground. Figure 3 defines the pin assignments and wire color code for the 11764-60001/60002/60003 drive cables. Table 1 is a solenoid drive pin and attenuation guide. Table 2 (on page 4) defines recommended attenuation section activation.

As a section is switched, the internal contacts of the activated coil open, thus shutting off current flows. At the same time, the internal contacts for the other coil close so that it can be activated when desired. Figure 1 shows a section that has been switched to the attenuator card position (note the closed thru line coil contact). The switching is “break-before-make” type, thus momentary interruption of the RF signal occurs at switching.

Although all sections can be switched simultaneously, the attenuator driver must not allow both pins of the same section (e.g. Section 1, pins 1 and 2) to be activated concurrently, or else that section would cycle rapidly. All terminals are “floating,” so bipolar or unipolar power supplies can be used.

Typical driver circuit

Figure 1 shows an economical TTL compatibility driver circuit for a single attenuation section that utilizes an IC relay driver and an inverter. A TTL “HI” input to the driver switches in the attenuator card, while a “LO” will activate the thru line for that section. This provides a complimentary driver for the section that assures that only one solenoid of the pair is activated at a time.

Switch position can be indicated remotely by utilizing the open and closed states of the internal coil contacts. Connected at A and B in Figure 1 are two indicator circuits, one providing a TTL output and one that activates an LED. These circuits will output a TTL “HI” (LED lamp “ON”) if the attenuator card is in the RF circuit, and will output a TTL “LO” (LED lamp “OFF”) if the thru line is in the RF circuit. Since current is drawn through the coil for these circuits, inadvertent switching is prevented by limiting the current to 5 mA.

Keysight assumes no responsibility for the use of any circuits described herein and makes no representation or warranties, express or implied, that such circuits are free from patent infringement.

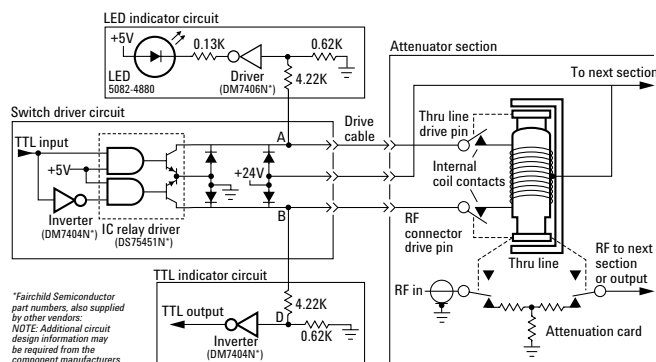

Figure 1: Driver and indicator circuits for one section of a Keysight 8494/5/6/7

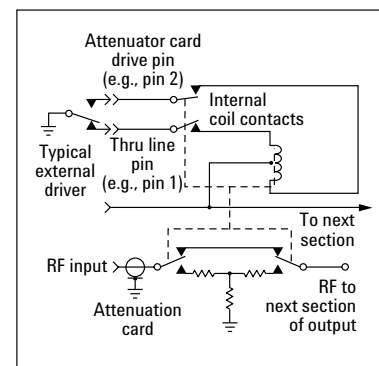

Figure 2: Section electrical diagram

GPIB attenuator/switch driver

Employing programmable step attenuators and switches in an automatic test system becomes an easy task when the Keysight 11713A attenuator/switch driver is specified into the system.

The 11713A has all of the necessary features to provide GPIB control of up to two programmable attenuators of the 8494/5/6/7 Series as well as the 84904/5/6/7/8 Series, and concurrently up to two electro-mechanical switches (e.g., the 8761B or 8762 Series).

The 11713A includes an integral power supply (with short circuit protection) that can simultaneously provide 125 milliamps at 24 volts to all contacts for control of the attenuators and switches, so no external power supply is needed. Connecting between the 11713A and the 84904/5/8 step attenuators is easy with the 11764-60004 drive cable.

The 11713A also features convenient front panel keys so the user can manually activate the individual attenuation sections and switches when in the “local” mode. Switching time for the drivers is less than 10 milliseconds.

For test systems using Keysight 70000 modular measurement system, automatic control of these products is easy using the 70611A-attenuator/switch driver. The 70611A has a versatile, easy to use manual interface when used with the 70004 color display. Each 70611A is capable of driving up to 31 SPDT electromechanical switches or a combination of several step attenuators and switches.

Optional calibration data for the Keysight 84904/5/8

Use of calibration data (i.e., accuracy, recorded, data of a device’s characteristics) has always been an effective means of reducing measurement uncertainty at RF and microwave frequencies. Step attenuators have long been used as reference standards in the measurement of gain, attenuation, and receiver sensitivity. Since the accuracy specifications include margins for frequency response and unit-to-unit variations, calibration data can improve overall measurement uncertainty.

Calibration data is available as Option UK6 and is generated from measurements made by a Keysight 8510 automatic network analyzer. Option UK6 provides a tabular list of attenuation and reflection coefficients in 250 MHz steps from 1500 MHz to 50 GHz. Measurements are traceable to NIST (National Institute of Standards and Technology, formerly NBS) standards and feature very low measurement uncertainties (Table 3 on page 6).

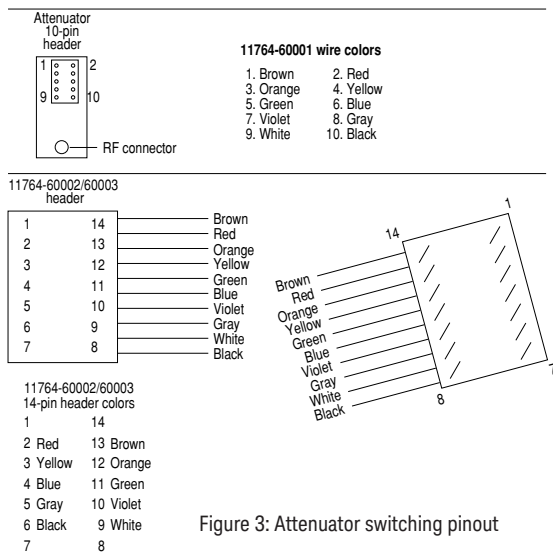

Figure 3: Attenuator switching pinout

Table 1. Solenoid pin and attenuator guide

Section: Model number	Section 1		Section 2		Section 3		Section 4		+Voltage supply
	Thru line	Attn card	Thru line	Attn card	Thru line	Attn card	Thru line	Attn card	
84904M									
Attenuation (dB)	0	1	0	2	0	4	0	4	
Attenuator actuating pin	1	2	5	8	4	9	6	7	10
11764-60001 Pin header colors	BRN	RED	GRN	GRAY	YEL	WHT	BLU	VIO	BLK
11764-60004 Viking plug pin number	5	6	7	8	9	10	11	12	1
11764-60002/60003 flat header dip pin number	13	2	11	5	3	9	4	10	6
84905M									
Attenuation (dB)	0	10	0	20	0	30			10
Attenuator actuating pin	1	2	5	8	4	9			BLK
11764-60001 Pin header colors	BRN	RED	GRN	GRAY	YEL	WHT			1
11764-60004 Viking plug pin number	5	6	7	8	9	10			6
11764-60002/60003 flat header dip pin number	13	2	11	5	3	9			
84908M									
Attenuation (dB)	0	5	0	10	0	20	0	30	
Attenuator actuating pin	1	2	5	8	4	9	6	7	10
11764-60001 Pin header colors	BRN	RED	GRN	GRAY	YEL	WHT	BLU	VIO	BLK
11764-60004 Viking plug pin number	5	6	7	8	9	10	11	12	1
11764-60002/60003 flat header dip pin number	13	2	11	5	3	9	4	10	6

Recommended switching sequence: The following switching sequence (i.e.) which 4 dB section to use for the 84904M should be followed to insure performance to specifications.)

Table 2. Attenuator section activation guide

Attenuation selected														
84904M	0 dB	1 dB	2 dB	3 dB	4 dB	5 dB	6 db	7 dB	8 dB	9 dB	10 dB	11 dB		
Section 1 (1 dB)		X		X		X		X		X		X		
Section 2 (2 dB)			X	X			X	X			X	X		
Section 3 (4 dB)					X	X	X	X	X	X	X	X		
Section 4 (4 dB)									X	X	X	X		
84905M	0 dB	10 dB	20 dB	30 dB	40 dB	50 db	60 dB							
Section 1 (10 dB)		X			X		X							
Section 2 (20 dB)			X			X	X							
Section 3 (30 dB)				X	X	X	X							
84908M	0 dB	5 dB	10 dB	15 dB	20 dB	25 db	30 dB	35 dB	40 dB	45 dB	50 dB	55 dB	60 dB	65 dB
Section 1 (5 dB)		X		X		X		X		X		X		X
Section 2 (10 dB)			X	X					X	X			X	X
Section 3 (20 dB)					X	X					X	X	X	X
Section 4 (30 dB)							X	X	X	X	X	X	X	X

Switching notes: Attenuator actuating pins relate to 10-pin attenuator header as shown (Figure 3), NOT terminating connector on any attached drive cable. Solenoids are magnetic latching type; drive voltage may be removed after switching. Current is self-interrupting in less than 20 ms.

Table 3. Keysight 84904/5/8M attenuation data uncertainties

Attenuation (dB)	DC to 2 GHz	2 to 20 GHz	20 to 40 GHz	40 to 50 GHz
0	±.0305	±.0546	±.1256	±.1597
1-11	±.0297	±.0515	±.1238	±.1699
15	±.0342	±.0516	±.1263	±.1968
20	±.0334	±.0521	±.1240	±.1849
25	±.0358	±.0522	±.1251	±.1997
30	±.0432	±.0535	±.1283	±.2219
35	±.0729	±.1050	±.2521	±.3918
40	±.0729	±.1050	±.2521	±.3918
45	±.0774	±.1051	±.2546	±.4187
50	±.0766	±.1056	±.2523	±.4068
55	±.0790	±.1057	±.2534	±.4216
60	±.0864	±.1070	±.2566	±.4438
65	±.1161	±.1585	±.3804	±.6137

Attenuation setting

Attenuation accuracy (±-dB; referenced from 0 dB setting):													
Model number 84904M													
Attenuator setting (dB):	1	2	3	4	5	6	7	8	9	10	11		
Frequency range													
DC to 18 GHz	0.35	0.45	0.55	0.55	0.55	0.55	0.60	0.60	0.65	0.70	0.80		
18 to 26.5 GHz	0.40	0.50	0.70	0.70	0.70	0.70	0.80	0.80	0.85	0.90	1.10		
26.5 GHz to 40 GHz	0.60	0.60	0.80	0.80	0.80	0.90	1.10	1.10	1.20	1.30	1.50		
40 to 50 GHz	0.60	0.70	0.80	0.80	0.80	0.90	1.10	1.10	1.20	1.30	1.50		
Model number 84905M													
Attenuator setting (dB):	10	20	30	40	50	60							
DC to 40 GHz	0.5	0.6	0.7	1.0	1.2	1.6							
40 to 50 GHz	0.7	0.8	1.0	1.3	1.5	1.8							
Model number 84908M													
Attenuator setting (dB):	5	10	15	20	25	30	35	40	45	50	55	60	65
DC to 40 GHz	0.5	0.5	0.6	0.6	0.7	0.7	1.0	1.0	1.2	1.2	1.6	1.6	1.8
40 to 50 GHz	0.7	0.7	0.8	0.8	1.0	1.0	1.3	1.3	1.5	1.5	1.8	1.8	2.0

1. Step-to-step accuracy is the maximum variation from the nominal step size when changing attenuation values. Its is a second specification on accuracy, and is used in combination with the absolute accuracy specifications to limit maximum allowable variation from nominal. Typical step-to-step accuracy for the 84905M and 84908M is ±1.0 dB to 50 GHz; for the 84904M is ± 0.5 to 50 GHz.

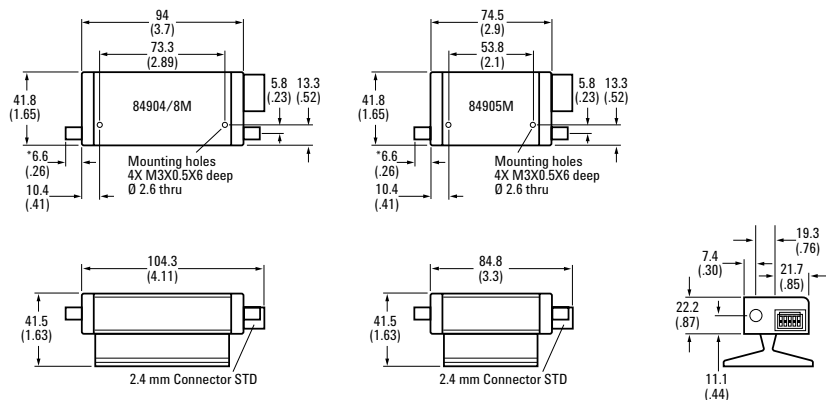

Figure 4: Product outlines

Specifications

Maximum insertion loss	84904M	84905M	84908M
------------------------	--------	--------	--------

DC to 40 GHz

(in dB 0 dB position, f = frequency in GHz)

(.8 + .04*f)	(.6 + .03*f)	(.8 + .04*f)
3.0	2.6	3.0

40 to 50 GHz

NOTE: At 75 ° C, increase insertion loss by .006*f (where f = frequency in GHz)

SWR			
DC to 12.4 GHz	1.3	1.25	1.3
12.4 to 34 GHz	1.7	1.5	1.7
34 to 40 GHz	1.8	1.7	1.8
40 to 50 GHz	3.0	2.6	3.0

Attenuation temperature coefficient

Less than .0001 dB/dB/°C

Power sensitivity

.001 dB/Watt

RF input power (maximum)

1 Watt average, 50 Watts peak

(10 microseconds max. pulse width)

Life (minimum)

2 million cycles per section

Repeatability

0.03 dB, typical

Environmental capabilities

(Up to 2 million cycles)

Temperature, operating

-20 °C to +75 °C

Temperature, non-operating

-55 °C to +85 °C

Altitude, operating

4,570 meters (15,000 feet)

Altitude, non-operating

13,700 meters (50,000 feet)

Humidity

Cycling 10 days, 65 °C at 95% RH

Shock, operating

10 Gs, 6 ms, on six sides, three blows

Shock, non-operating

500 Gs, 0.5 ms, in six directions

Vibration, operating

5 Gs, 34-500 Hz;
2 Gs, 500-2000Hz

EMC

Radiated interference is within the requirements of MIL-STD-461 method RE02, VDE 0871 and CISPR Publication II

Mechanical information

Net weight	84904M	84905M	84908M
	291 grams (10.3 oz)	229 grams (8.1 oz)	291 grams (10.3 oz)

Mounting position (any)

RF connectors
2.4mm female connectors (Option 101)
2.4mm female and 2.4 mm male (Option 100)

Switching speed

Maximum 20 milliseconds including settling time

Solenoids	Coil voltage	Switching current	Nominal coil impedance
Option 024	24 V (20 to 30 V)	125 mA (at 24 V)	185 Ohms
Option 015	15 V (13 to 22 V)	188 mA (at 15 V)	80 Ohms
Option 011	5 V (4.5 to 7 V)	325 mA (at 5 V)	17 Ohms

Switching current is current per section; approximately 10 ms duration before internal contacts open the coil circuit

Ordering information

84904M	84905M	84908M
0 to 11 dB	0 to 60 dB	0 to 65 db
1 dB steps	10 dB steps	5 dB steps

Options

Option	Description
011	5 volt solenoids
015	15 volt solenoids
024	24 volt solenoids
100	2.4 mm female connector on dc drive cable end, male 2.4 mm connector on opposite end
101	2.4 mm female connector on dc drive cable end, female 2.4 mm connector on opposite end
UK6	Calibration data

Attenuator Accessories

Model Number	Description
11764-60001	10-pin dip plug (for attenuator connection) to 1524 mm (5-foot) ribbon cable (no second connector)
11764-60002	203 mm (8-inch) ribbon cable with 14-pin headers, female 10-pin receptacle (for attenuator connection)
11764-60003	406 mm (16 inch) ribbon cable with 14-pin headers, female 10-pin receptacle (for attenuator connection)
11764-60004	Interconnect cable 10-pin dip plug (for attenuator connection) to "Viking" connector (for 11713A connection) for use with a 11713A attenuator/switch driver