

Product Datasheet - Technical Specifications



More information in our Web-Shop at ► www.meilhaus.com and in our download section.

Your contact

**Technical and commercial sales, price information,
quotations, demo/test equipment, consulting:**

Tel.: **+49 - 81 41 - 52 71-0**

FAX: **+49 - 81 41 - 52 71-129**

E-Mail: sales@meilhaus.com

Downloads:
www.meilhaus.com/en/infos/download.htm

Meilhaus Electronic GmbH | Tel. **+49 - 81 41 - 52 71-0**
Am Sonnenlicht 2 | Fax **+49 - 81 41 - 52 71-129**
82239 Alling/Germany | E-Mail sales@meilhaus.com

Mentioned company and product names may be registered trademarks of the respective companies. Prices in Euro plus VAT. Errors and omissions excepted.
© Meilhaus Electronic.

www.meilhaus.de

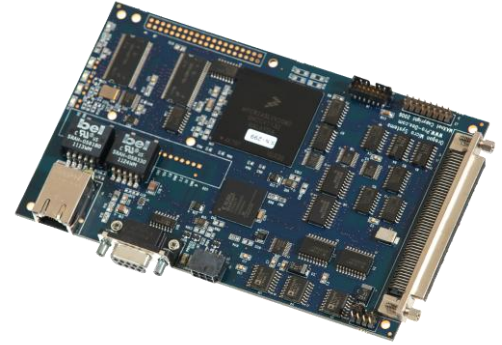

MAXnet

Ethernet 5-Axis Motion Controller

FEATURES

Ethernet or RS232 Communications

- Ethernet utilizes standard TCP/IP protocol.
- RS232 Baud rate = 9600 to 115.2K

PID update rate of 122 μ s on all 5 axes

- Delivers exceptional servo control on multi-axis applications.
- Identical outcomes when utilizing one or all axes of motion.
- Configurable PID filter with feed forward coefficients.

266 MHz, 32-bit RISC processor

- Updates all signals and data points providing superior application control.

Controller I/O Capabilities

- Each axis has +Limit, -Limit, Home, Auxiliary out, and axis control out.
- 8 General purpose bi-directional TTL I/O
- 1 General purpose analog output with 16 bit, +/-10 VDC input (in addition to axes output).
- 2 Channels of general purpose analog input with 16-bit (+/-10 VDC)

Motion Feedback

- Each axis has an incremental encoder input
- Quadrature Encoder Feed back up to 16 MHz on all encoder inputs.

Sophisticated Control Functionality

- 16 bit DAC analog resolution.
- Step pulses from 0 to 4,194,303 steps per second (+/- 0 steps).
- Backlash compensation.
- Custom, parabolic, "S"-Curve & linear trajectory profiles.
- Real time encoder position capture.
- S-Curve with 4-quadrant jerk parameters.

Control signals

- Single 100-pin SCSI type connector for high density signal connection.
- 8 "user definable" digital I/O.
- Analog out per each axis can be used as general purpose when axis is configured for Step control.

ADDITIONAL FEATURES

- Small form-factor, 4in. x 6.5in.
- Stand-alone capability
- Custom Power-up Defaults
- Non-Volatile Macro Storage
- Patented technology to minimize torque ripple and velocity modulation
- Internal Watchdog timer for safety
- Slip & Stall detection with encoder feedback
- Linear/Circular interpolation
- Constant and variable velocity contouring (all axes)
- Single-axis, multi-axis and multi-tasking modes
- Output is +/-10V, or Step & Direction per Axis
- Independent home and plus / minus over-travel inputs for each axis
- Auxiliary output per axis for Amp/Drive enable
- Commands are intuitive for programming ease.
- Over 250 ASCII character commands, "universal" to current and previous OMS controllers
- Capable of conversion to "user" defined units i.e. inches/ revolutions if desired.
- Designed for expandability (custom solutions)
- OMS has more than 28 years proven success

DESCRIPTION

The MAXnet family of Motion Controllers brings the Oregon Micro Systems, Inc. (OMS) intelligent motion control technology to a new level of servo applications as well as stepping motors. A much more powerful 266 MHz 32 Bit RISC processor (PowerPC) provides the capability and power for better and more sophisticated application control. This newest generation of motion control products provides up to 5 axes of motion control on a single 4 x 6.5 inch card. Each axis can be selected by the user to be an open or closed stepper or a high capability servo axis. In addition, independent analog inputs are provided to enable integration of analog parameters such as velocity override, temperature, pressure, etc., under the control of the running application. An additional general purpose analog output is also available.

Outputs are provided for 16 bit analog servo output as well as step and direction for stepper system applications. The servo loop is a PID filter with feed-forward coefficients and an update rate of 122 μ s on all 5 axes. Independent plus and minus limits, a home switch input, and an auxiliary output provided for each of the 5 axes so that the state of any of them can be monitored by the system at any time. An additional 8 User Definable I/O is available for synchronization and control of other events. Incremental encoder feedback, differential or single ended, is used for all servo axes and is available for position feedback and may also be used for slip or stall detection.

PROGRAMMING

The MAXnet motion controllers are easily programmed with character ASCII commands through an extensive command structure. The commands are combined into character strings to create sophisticated motion profiles, with features such as IO and other functionality. A separate FIFO command queue for each axis is used to store the commands once they are parsed in the MAXnet. These commands are then executed sequentially, allowing the host to send a complex command sequence and attend to other tasks, while the MAXnet manages the motion process. These command queues can store 2559 command values and can include a loop counter that allows multiple execution of any command string.

There are approximately 200 commands available. All commands are sent to the controller as two or three character strings. Some of these commands expect one or more numerical operands to follow. These commands are identified with “#” after the command in the description. The “#” indicates a signed integer input parameter, or a signed fixed point number of the format ##.# when User Units are enabled. User Units define distances, Velocity and acceleration parameters, and represent the input in Inches, millimeters, revolution, etc.

Synchronized moves may be made by entering the AA or AM command mode. This form of the command performs a context switch that allows entering commands in the format MRx#,y#,z#,t#,u#;

Numbers are entered for each axis commanded to move. An axis may be skipped by entering a comma {,} at the appropriate axis position with no value parameter. The command may be prematurely terminated with a semicolon (;) i.e. a move requiring only the X and Y axes to move would use the command MRx#,y#; followed by the GO command. Each axis programmed to move will start together upon execution of the GO command. The MAXnet can be switched back to independent-axis mode by entering the desire single axis command, such as AX.

PROGRAMMING EXAMPLES

In a typical move requirement where it is desired to home the stage and then move to a specified position, the following will demonstrate the programming for a single axis:

Initialize the velocity and acceleration parameters to a suitable value. Set the PID filter gain values. Perform the homing operation initializing the position counter to zero. Perform a motion to the absolute position of 10,000 and set the done flag for that axis when the move is finished.

```
AX;
VL5000;
AC50000;
KP20;
K11;
KD45;
HN;
HM0;
MA10000;
GO;
ID;
```

In a move requiring a three axis coordinated move to a position, the following could be used:

```
AX;
KP2;
KD6;
HN;
AY;
KP2;
KD6;
HN;
AZ;
KP2;
KD6;
HN;
AM;
VL5000,5000,5000;
AC50000,50000,50000;
MA1000,2000,3000;
GO;
ID;
```

The controller would calculate the relative velocities required to perform a straight line move from the current position to the desired position.

SPECIFICATIONS

Velocity

0 to 4,194,303 pulses per second simultaneous on each axis

Acceleration

0 to 8,000,000 pulses per second per second

Position range

$\pm 2,147,487,647$

Accuracy

Position accuracy and repeatability ± 0 counts for point to point moves

Velocity accuracy $\pm 0.01\%$ of peak velocity in jog mode.

Environmental

Operating temperature range: 0 to 50 degrees centigrade

Storage temperature range: -20 to 85 degrees centigrade

Humidity: 0 to 90% non-condensing

Power

+5VDC $\pm 5\%$ at 1 amp typical

+12VDC at 0.1 amp typical = $\pm 5\%$

-12VDC at 0.1 amp typical = $\pm 10\%$

Dimensions

4" x 6.5" x 0.7"

Limit switch inputs

TTL input signals

Active low or high, selectable by command input for each axis (active low is default)

Connector

One shielded 100-Pin SCSI type connector for all signals (motor control, I/O, Limits, etc). Breakout board available for ease of cabling.

Home switch inputs

TTL input signals

Active low or high, selectable by command input for each axis (active low is default)

User definable I/O

Up to 8 bits of user definable digital I/O. The 8 bits are user configurable and are configured as 4 inputs and 4 outputs as defaults from the factory.

Analog inputs

Two independent analog inputs, 16 Bit resolution, $\pm 10V$.

Analog outputs (servo)

$\pm 10V$ and 0 to +10V, max. One per axis plus one general purposes, 16 Bit resolution

Step pulse output

Pulse width 50% duty cycle. Open collector level signal (TTL).

Direction output

Open collector level signal (TTL).

Encoder feedback

Maximum 16 MHz after 4x quadrature detection. Differential signal.

Reference

IEEE 802

Software

Software interface utilities provided.

High level expertise not required.

Over 250 ASCII character commands, expanded from current OMS command set while backwards compatible.

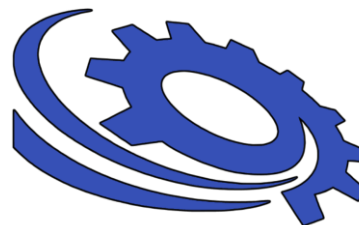

"The Company in Motion"

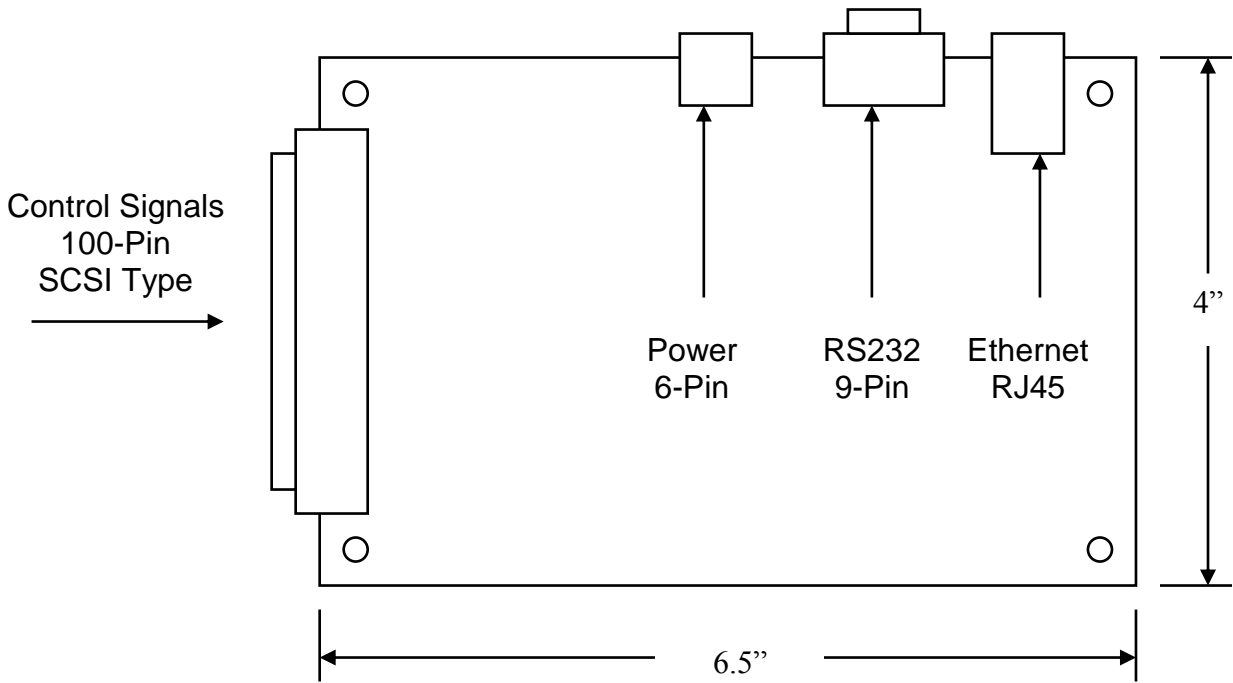

Ordering Information	
Model	No. of Axes
MAXnet-1000	1
MAXnet-2000	2
MAXnet-3000	3
MAXnet-4000	4
MAXnet-5000	5

ACCESSORIES	
IOMAXnet	I/O Breakout Board for MAXnet
CBL58-3M	I/O cable for MAXnet to IOvMAX, 3 meters



3701-1800000
Revision C



MAXnet w/DBnet

Ethernet 10-Axis Motion Controller



FEATURES

Ethernet or RS232 Communications

- Ethernet utilizes standard TCP/IP protocol.
- RS232 Baud rate = 9600 to 115.2K

PID update rate of 122 μ s on all 10 axes

- Delivers exceptional servo control on multi-axis applications.
- Identical outcomes when utilizing one or all axes of motion.
- Configurable PID filter with feed forward coefficients.

266 MHz, 32-bit RISC processor

- Updates all signals and data points providing superior application control.

Controller I/O Capabilities

- Each axis has +Limit, -Limit, Home, Auxiliary out, and axis control out.
- 16 General purpose bi-directional TTL I/O
- 2 General purpose analog output with 16 bit, +/-10 VDC input (in addition to axes output).
- 4 Channels of general purpose analog input with 16-bit (+/-10 VDC)

Motion Feedback

- Each axis has an incremental encoder input
- Quadrature Encoder Feed back up to 16 MHz on all encoder inputs.

Sophisticated Control Functionality

- 16 bit DAC analog resolution.
- Step pulses from 0 to 4,194,303 steps per second (+/- 0 steps).
- Backlash compensation.
- Custom, parabolic, "S"-Curve & linear trajectory profiles.
- Real time encoder position capture.
- S-Curve with 4-quadrant jerk parameters.

Control signals

- Two 100-pin SCSI type connectors for high density signal connection.
- 16 "user definable" digital I/O.
- Analog out per each axis can be used as general purpose when axis is configured for Step control.

ADDITIONAL FEATURES

- Small form-factor, 4in. x 6.5in.
- Stand-alone capability
- Custom Power-up Defaults
- Non-Volatile Macro Storage
- Patented technology to minimize torque ripple and velocity modulation
- Internal Watchdog timer for safety
- Slip & Stall detection with encoder feedback
- Linear/Circular interpolation
- Constant and variable velocity contouring (all axes)
- Single-axis, multi-axis and multi-tasking modes
- Output is +/-10V, or Step & Direction per Axis
- Independent home and plus / minus over-travel inputs for each axis
- Auxiliary output per axis for Amp/Drive enable
- Commands are intuitive for programming ease.
- Over 250 ASCII character commands, "universal" to current and previous OMS controllers
- Capable of conversion to "user" defined units i.e. inches/ revolutions if desired.
- Designed for expandability (custom solutions)
- OMS has more than 28 years proven success

DESCRIPTION

The MAXnet family of Motion Controllers along with the DBnet daughter board provides an unmatched 10-axis of motion control of Stepper and/or Servo motors. This brings a new level technology to servo applications as well as stepping motors. A much more powerful 266 MHz 32 Bit RISC processor (PowerPC) provides the capability and power for better and more sophisticated application control. This newest generation of motion control products provides up to 10 axes of motion control on a two-board stack measuring 4 x 6.5 inch card. Each axis can be selected by the user to be an open or closed stepper or a high capability servo axis. In addition, independent analog inputs are provided to enable integration of analog parameters such as velocity override, temperature, pressure, etc., under the control of the running application. An additional general purpose analog output is also available.

Outputs are provided for 16 bit analog servo output as well as step and direction for stepper system applications. The servo loop is a PID filter with feed-forward coefficients and an update rate of 122 μ s on all 10 axes. Independent plus and minus limits, a home switch input, and an auxiliary output provided for each of the 10 axes so that the state of any of them can be monitored by the system at any time. An additional 16 User Definable I/O is available for synchronization and control of other events. Incremental encoder feedback, differential or single ended, is used for all servo axes and is available for position feedback and may also be used for slip or stall detection.

PROGRAMMING

The MAXnet motion controllers are easily programmed with character ASCII commands through an extensive command structure. The commands are combined into character strings to create sophisticated motion profiles, with features such as IO and other functionality. A separate FIFO command queue for each axis is used to store the commands once they are parsed in the MAXnet. These commands are then executed sequentially, allowing the host to send a complex command sequence and attend to other tasks, while the MAXnet manages the motion process. These command queues can store 2559 command values and can include a loop counter that allows multiple execution of any command string.

There are approximately 250 commands available. All commands are sent to the controller as two or three character strings. Some of these commands expect one or more numerical operands to follow. These commands are identified with “#” after the command in the description. The “#” indicates a signed integer input parameter, or a signed fixed point number of the format ##.# when User Units are enabled. User Units define distances, Velocity and acceleration parameters, and represent the input in Inches, millimeters, revolution, etc.

Synchronized moves may be made by entering the AA or AM command mode. This form of the command performs a context switch that allows entering commands in the format MRx#,#,#,z#,#,u#,v#,r#,s#,w#,k#;

Numbers are entered for each axis commanded to move. An axis may be skipped by entering a comma {,} at the appropriate axis position with no value parameter. The command may be prematurely terminated with a semicolon (;) i.e. a move requiring only the X and Y axes to move would use the command MRx#,y#; followed by the GO command. Each axis programmed to move will start together upon execution of the GO command. The MAXnet can be switched back to independent-axis mode by entering the desired single axis command, such as AX.

PROGRAMMING EXAMPLES

In a typical move requirement where it is desired to home the stage and then move to a specified position, the following will demonstrate the programming for a single axis:

Initialize the velocity and acceleration parameters to a suitable value. Set the PID filter gain values. Perform the homing operation initializing the position counter to zero. Perform a motion to the absolute position of 10,000 and set the done flag for that axis when the move is finished.

```
AX;
VL5000;
AC50000;
KP20;
KI1;
KD45;
HN;
HM0;
MA10000;
GO;
ID;
```

In a move requiring a three axis coordinated move to a position, the following could be used:

```
AX;
KP2;
KD6;
HN;
AY;
KP2;
KD6;
HN;
AZ;
KP2;
KD6;
HN;
AM;
VL5000,5000,5000;
AC50000,50000,50000;
MA1000,2000,3000;
GO;
ID;
```

The controller would calculate the relative velocities required to perform a straight line move from the current position to the desired position.

SPECIFICATIONS

Velocity

0 to 4,194,303 pulses per second simultaneous on each axis

Acceleration

0 to 8,000,000 pulses per second per second

Position range

± 2,147,487,647

Accuracy

Position accuracy and repeatability ±0 counts for point to point moves

Velocity accuracy ±0.01% of peak velocity in jog mode.

Environmental

Operating temperature range: 0 to 50 degrees centigrade

Storage temperature range: -20 to 85 degrees centigrade

Humidity: 0 to 90% non-condensing

Power

+5VDC +/-5% at 1 amp typical

+12VDC at 0.1 amp typical = +/-5%

-12VDC at 0.1 amp typical = +/-10%

Dimensions

4" x 6.5" x 1.4"

Limit switch inputs

TTL input signals

Active low or high, selectable by command input for each axis (active low is default)

Connector

One shielded 100-Pin SCSI type connector for all signals (motor control, I/O, Limits, etc). Breakout board available for ease of cabling.

Home switch inputs

TTL input signals

Active low or high, selectable by command input for each axis (active low is default)

User definable I/O

Up to 16 bits of user definable digital I/O. The 16 bits are user configurable and are configured as 8 inputs and 8 outputs as defaults from the factory.

Analog inputs

Two independent analog inputs, 16 Bit resolution, +/- 10V.

Analog outputs (servo)

+/-10V and 0 to +10V, max. One per axis plus one general purposes, 16 Bit resolution

Step pulse output

Pulse width 50% duty cycle. Open collector level signal (TTL).

Direction output

Open collector level signal (TTL).

Encoder feedback

Maximum 16 MHz after 4x quadrature detection. Differential signal.

Reference

IEEE 802

Software

Software interface utilities provided.

High level expertise not required.

Over 250 ASCII character commands, expanded from current OMS command set while backwards compatible.

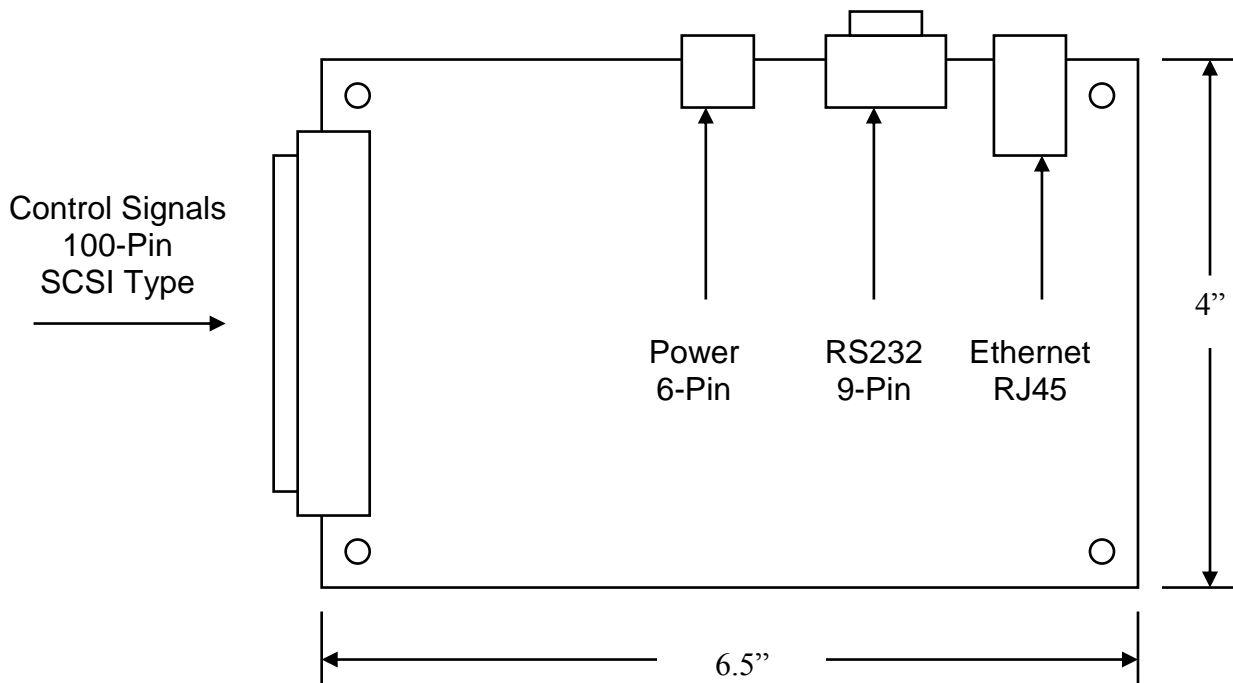

Ordering Information	
Model	No. of Axes
MAXnet-1000	1
MAXnet-2000	2
MAXnet-3000	3
MAXnet-4000	4
MAXnet-5000	5
MAXnet-6000	6
MAXnet-7000	7
MAXnet-8000	8
MAXnet-9000	9
MAXnet-A000	10



ACCESSORIES	
IOMAXnet	I/O Breakout Board for MAXnet
CBL58-3M	I/O cable for MAXnet to IOvMAX, 3 meters

3701-1800001
Revision C