

Product Datasheet - Technical Specifications



More information in our Web-Shop at ► www.meilhaus.com and in our download section.

Your contact

**Technical and commercial sales, price information,
quotations, demo/test equipment, consulting:**

Tel.: **+49 - 81 41 - 52 71-0**

FAX: **+49 - 81 41 - 52 71-129**

E-Mail: sales@meilhaus.com

Downloads:

www.meilhaus.com/en/infos/download.htm

Meilhaus Electronic GmbH | Tel. **+49 - 81 41 - 52 71-0**
Am Sonnenlicht 2 | Fax **+49 - 81 41 - 52 71-129**
82239 Alling/Germany | E-Mail sales@meilhaus.com

Mentioned company and product names may be registered trademarks of the respective companies. Prices in Euro plus VAT. Errors and omissions excepted.
© Meilhaus Electronic.

www.meilhaus.de

Manual

AudioAnalyzer (Analog + Digital) Rack Version

GET IN **touch**
WITH SENSITIVE TESTING

- Softline _____
- Modline _____
- Conline _____
- Boardline _____
- Avidline** _____
- Pixline _____
- Application _____

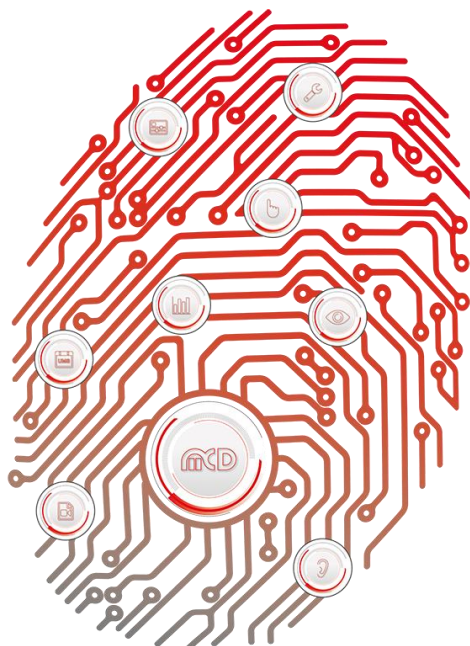
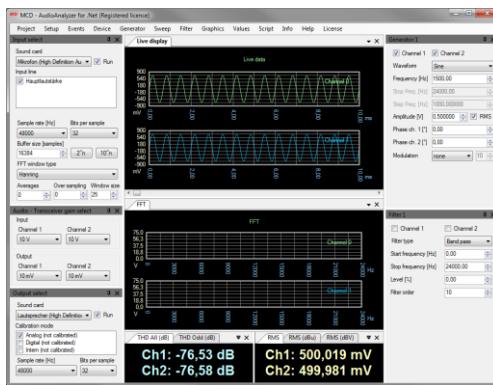

Table of Contents

1. GENERAL	5
1.1. ARCHITECTURE	5
1.2. FUNCTION / PROPERTIES	6
2. INSTALLATION	7
2.1. SYSTEM REQUIREMENT	7
2.2. INSTALLATION	7
2.3. DEINSTALLATION	8
3. INFO AND LICENSE	9
3.1. ABOUT	9
3.2. REGISTER	9
4. PROJECT MANAGEMENT	11
4.1. SAVE	11
4.2. LOAD	11
4.3. SAVE CURVE	11
4.4. LOAD CURVE	11
4.5. PRESETS	11
4.6. LOGGER	12
4.7. EXIT	12
5. DEVICE SELECTION	13
5.1. INPUT	13
5.2. OUTPUT	14
5.3. AUDIO GAIN	14
5.4. MIXER OVERVIEW	15
5.5. RESET	15
6. GENERATOR	16
6.1. GENERATOR 1 TO 5	16
6.2. MORE	17
6.3. GENERATOR DISPLAY	17
6.4. DISABLE ALL	17
6.5. WAVEFORMS	18
6.6. MODULATION TYPES	20

7. SWEEP	21
7.1. SWEEP	21
7.2. SWEEP DISPLAY	22
7.3. DISABLE ALL	22
7.4. WAVEFORMS	22
8. FILTER	24
8.1. FILTER 1 TO 5	24
8.2. MORE	25
8.3. FILTER DISPLAY	25
8.4. DISABLE ALL	25
9. VISUALIZATION	26
9.1. LIVE DISPLAY	26
9.2. FFT	27
9.3. PHASE	27
10. MEASUREMENT VALUES	28
10.1. VALUES LIST	28
10.2. FREQUENCY, RMS, THD, SN	29
10.3. RMS - METER	29
11. SETUP	30
11.1. OPTIONS	30
11.2. SHOW TOOLTIPS	31
11.3. INPUT CALIBRATION	31
11.4. OUTPUT CALIBRATION	32
12. COM / DCOM INTERFACE	32
12.1. CLASS NAME	32
12.2. GENERAL CONTROL COMMANDS	32
12.3. RECORDING CONTROL	33
12.4. AUDIO GAIN	34
12.5. PLAYBACK CONTROL	34
12.6. GENERATORS	35
12.7. SWEEP	36
12.8. FILTER	36
12.9. MEASUREMENT VALUES	37

13.	TECHNICAL DATA.....	39
13.1.	GENERAL NOTES.....	39
13.2.	TECHNICAL DATA IN DETAIL.....	39
13.2.1.	<i>Wiring and LED Indicators.....</i>	<i>39</i>
13.2.2.	<i>Block Diagram of Signal Paths.....</i>	<i>41</i>
13.2.3.	<i>Electrical and Mechanical Properties.....</i>	<i>41</i>
13.3.	INTERFACE DESCRIPTION.....	44
13.3.1.	<i>Set of Commands.....</i>	<i>44</i>
13.3.2.	<i>Command Implementation for Different Software Versions.....</i>	<i>46</i>

1. General

The AudioAnalyzer is a software - based solution for the analysis and generation of analog and digital signals in the audio range. Standard PC components can be used with Microsoft Windows XP® or successor operating systems (including Windows 7®).

For the analysis of audio signals in addition to frequency and different signal strength measurements, measurements of THD and the FFT spectrum are possible. The integrated signal generators and different wave forms of modulation can be generated. The surface of the AudioAnalyzer can be designed freely and is adaptable to various applications. All functions of the AudioAnalyzer can be controlled using a COM Server interface with other Windows® programs. The obtained measurement values can also be integrated into a wide variety programs. Special programming knowledge is not required for this. For input, both analog and digital signal sources can be used. The following document serves as a system manual and describes the installation, the architecture and functions of the AudioAnalyzer.

Order number: # 121158

1.1. Architecture

Audio signals are recorded via a sound card and provided to the AudioAnalyzer in digitalized form. Generated signals are also put out via the sound card. Optionally, an external amplifier is connected upstream to adapt different input levels. The attenuation of this amplifier can be controlled via a serial RS232 connection from the AudioAnalyzer again. In addition to the use of the AudioAnalyzer as an independent application, it is also possible to remotely control or query all the functions and values of other Windows® programs. For this purpose, a COM - Client / Server interface is utilized. The exact operation of this interface is described later in this document.

1.2. Function / Properties

- Modern and user - friendly user interface
- Extremely flexible design of the user interface
- Efficient FFT analysis
- Powerful generators (AM, FM, PM modulation)
- Easy to use filter
- Data Import and Export
- Support of multiple sound cards in one PC
- Extremely fast measurement functions for frequency response, phase transitions, and more
- Access to all mixer settings
- Very high accuracy of the measurement calculation
- Comprehensive measurement functions such as amplitude, RMS, frequency, harmonic distortion, phase and much more
- Automatic calculation and display of the frequency and phase response
- Typical measurement times of a frequency response 0 - 24 kHz at 200 - 300 ms
- Sweep functions
- Loading and saving of all settings via project files
- Remote control through all external systems
- Analog, digital inputs selectable via sound card selection
- Adaptation to the measuring signals via MCD Audio Gain Controller

2. Installation

The following section describes the installation of AudioAnalyzer.Net.

2.1. System Requirement

Software:

- Operating system: Windows 2000[®], Windows XP[®], Windows 7[®]
- Architecture: 32 bit or 64 bit
- .Net Framework: Starting from Version 2.0

Hardware:

- Windows[®] compatible audio controller (sound card) or MCD AudioAnalyzer (hardware)
- Minimum requirement for processor and hard drive

2.2. Installation

To install, call on the already provided *MCDAudioAnalyzer.Net.msi* installation program and follow the screen instructions. When you install an update, uninstall any previously or other existing version.



Figure 1: Open Installation Program MCD AudioAnalyzer.Net.msi

The program directory for the installation of the AudioAnalyzer can be set. It should be noted that the implementation of the AudioAnalyzer **copy rights** must exist for this directory.



Figure 2: Choose Installation Folder

To protect the AudioAnalyzer from unauthorized use, it is necessary to license these after the installation. A detailed description of licensing is done later in the document.

For demonstration and testing purposes, the AudioAnalyzer can be operated for 30 minutes without a license. Some program functions are deactivated.

2.3. Deinstallation

You can uninstall the customary route via *Windows Control Panel* → *Programs and Features*.

3. Info and License

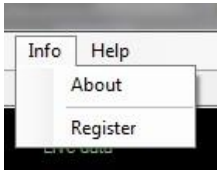

Figure 3: Info Menu

The visualization is the program version and the activation of the license for the AudioAnalyzer can be accessed via the Info menu.

3.1. About



Figure 4: Display of Version Information

3.2. Register

To activate the AudioAnalyzer, the following dialog will be used.

Here you can see:

1. The status of the license that is provided

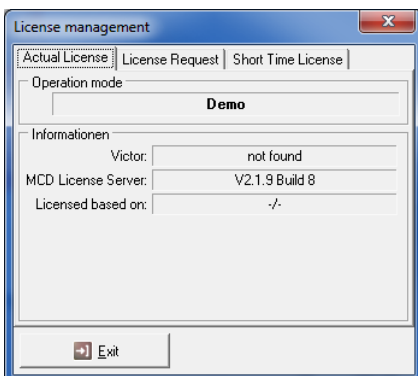

Figure 5: Actual License

2. A permanent license is required

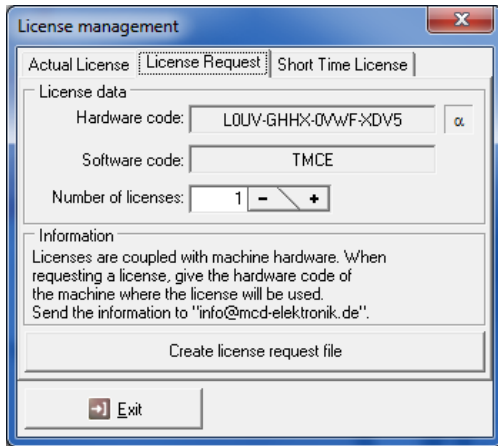

Figure 6: License Request

3. A short term license is activated

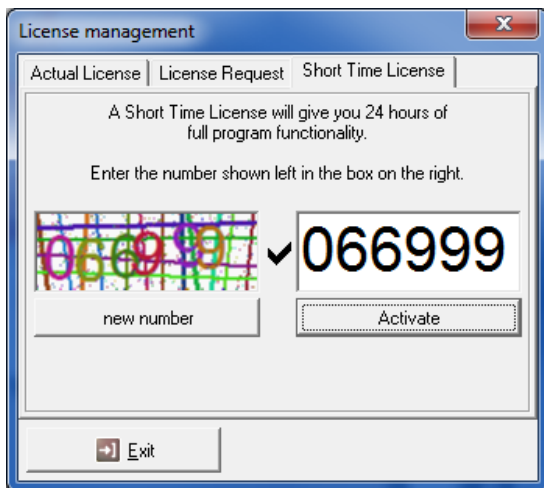

Figure 7: Short Time License

4. Project Management

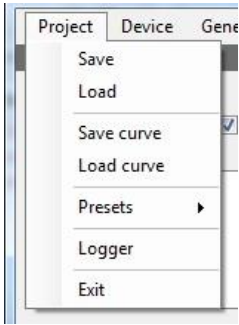

Figure 8: Project Menu

In the Project Menu, the current settings and the layout of the AudioAnalyzer can be saved and loaded. All windows can be freely positioned and arranged according to one's requirements. Furthermore, the logger can be activated and the program will be terminated.

4.1. Save

All the current settings can be saved in a project file via the *Save* command. Also, the current window positions are held therein.

4.2. Load

Saved settings may be previously loaded again via the *Load* command. The original window positions are restored.

4.3. Save Curve

Via the *Save curve* command the recently captured input curve can be saved.

4.4. Load Curve

Via the *Load curve* command a saved curve can be loaded again. All values of the curve (RMS, THD, FFT, phase, etc.) are calculated and displayed again. A running recording is stopped.

4.5. Presets

Predefined settings can be accessed here.

4.6. Logger

This command activates the log window. Depending on the settings in the setup, the AudioAnalyzer generates log messages (errors, warnings, information ...), which are displayed here.

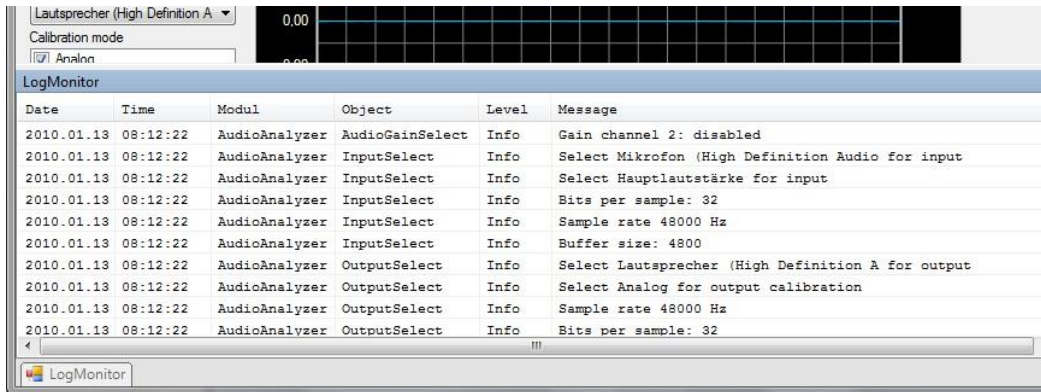

Figure 9: Log Monitor

4.7. Exit

This command closes the program. If the program was started as a COM Server, then it cannot be stopped here and this menu item is disabled.

5. Device Selection

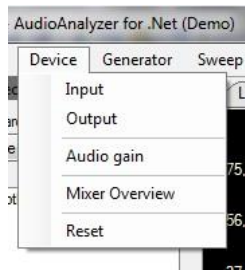

Figure 10: Device Selection

Here various machine settings can be made.

5.1. Input

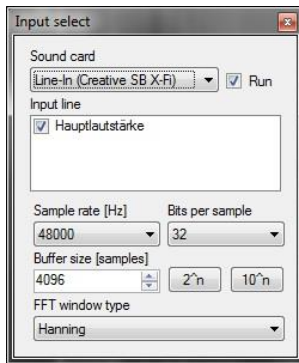

Figure 11: Input Selection

In this dialog, the sound card which should be used for the detection is selected. If the selected sound card has several inputs, then the desired input can be selected. With the check box *Run*, the recording is started or stopped.

The quality of the recording can be adjusted via *Sample rate* and *Bits per sample*. *Buffer size* determines the duration of a single exposure cycle.

Using the button 2^n increases the *Buffer size* to the next power of two. These values are particularly suitable for frequency response analysis and utilize the internal FFT analysis optimally.

Using the button 10^n multiplies the *Buffer size* to the next power of ten with the *Sample rate* increase. These values are particularly well suited for the graphical display (triggering).

Via the selection *FFT window type*, the window function used to compute the FFT analysis can be determined. In general, the selection of the Hanning - window is the best choice.

5.2. Output

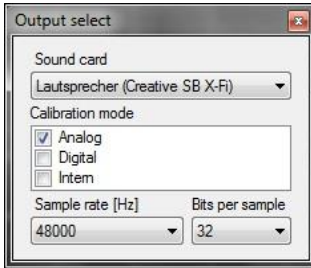

Figure 12: Output Selection

In this dialog the sound card, which is to be used for playback, is selected. In addition to that the sound cards usually always provide the output signal for several outputs simultaneously, three different calibration settings (analog, digital and internal) can also be selected. Settings of the playback quality can be set via *Sample rate* and *Bits per sample*.

5.3. Audio Gain



Figure 13: Audio Gain Selection

If, for the case of input matching, an Audio Gain Controller of the company MCD Elektronik is connected between the signal source and sound card and enabled in the setup, then you can set the desired measurement range. In addition, the determined correction factor is displayed.

5.4. Mixer Overview

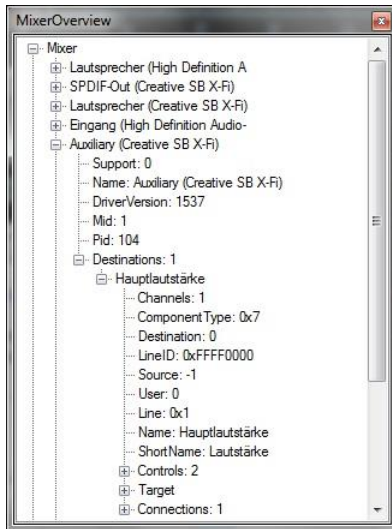

Figure 14: Mixer Overview

For test and diagnostic purposes, all mixer, playback and recording devices and their settings can be viewed here. In - depth knowledge for the application and interpretation of the Windows[®] - Sound - API are necessary.

5.5. Reset

Reset all settings (except the display) of the AudioAnalyzer to predefined values.

6. Generator

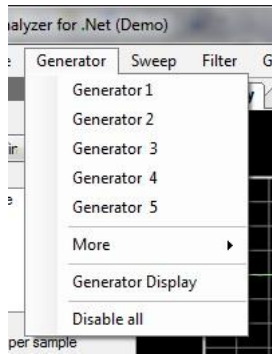

Figure 15: Generators

With the help of generators, the most diverse output signals can be created with the AudioAnalyzer. There are up to 10 generators. The outputs of the generators may be either mixed or modulated.

6.1. Generator 1 to 5

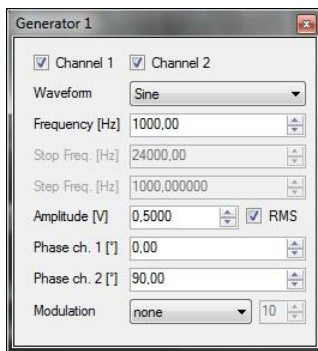

Figure 16: Generator Settings

Here you can directly call on the first 5 generators. The following settings can be made for each generator:

- Activation of channels 1 and / or 2
- Waveform (see below)
- Frequency
- Start frequency for a multi - sine
- Stop frequency for a multi - sine
- Step size for a multi - sine
- Amplitude
- Identification of whether the amplitude is given as RMS (for sinus waveforms)
- Channel 1 phase shift
- Channel 2 phase shift
- Selection of the modulation (none, AM, FM, PM → see below)
- Selection of the generator, which is to be modulated.

If a modulation is selected, then the generator does not directly produce an output signal but the signal of this generator is used to modulate a different generator. So no back-coupling occurs, a generator can always modulate only one subsequent generator.

6.2. More

Here generators 6 to 10 can be accessed.

6.3. Generator Display

For visualization of the generated waveform, a curve output can be called here.

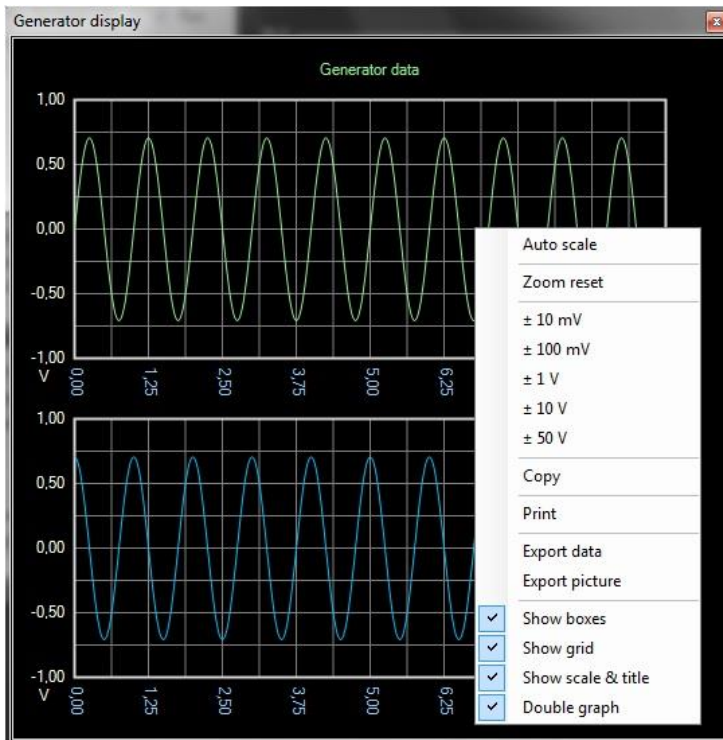

Figure 17: Generator Display

In this display, you can enlarge the display by using the left mouse button. Using the right mouse button, a context menu can be activated, in which various settings (see figure) can be made.

Furthermore, the curve data can be printed or exported here.

6.4. Disable All

Turns off all generators.

6.5. Waveforms

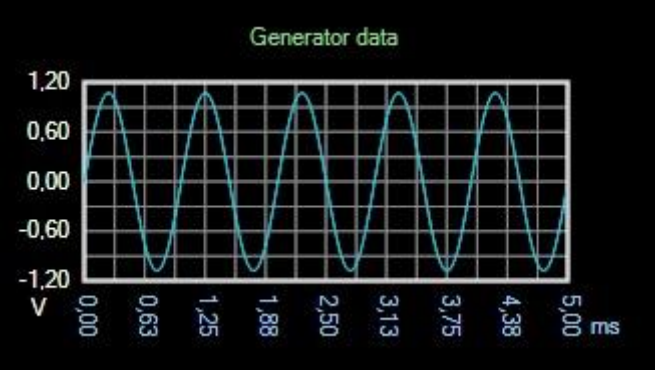
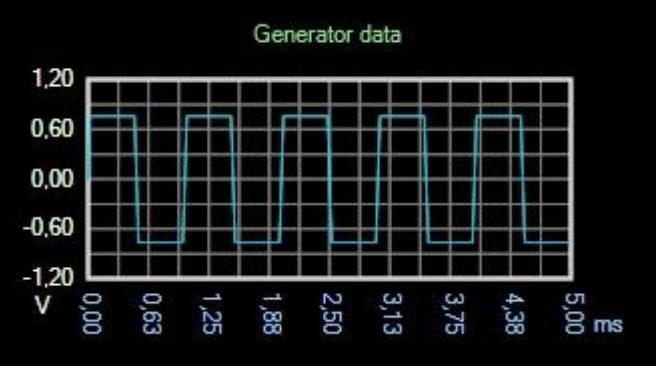
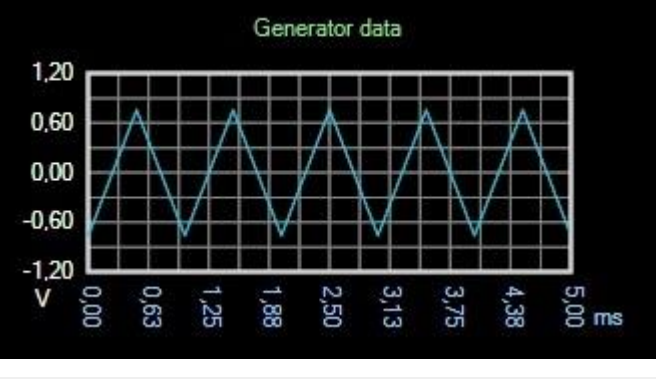
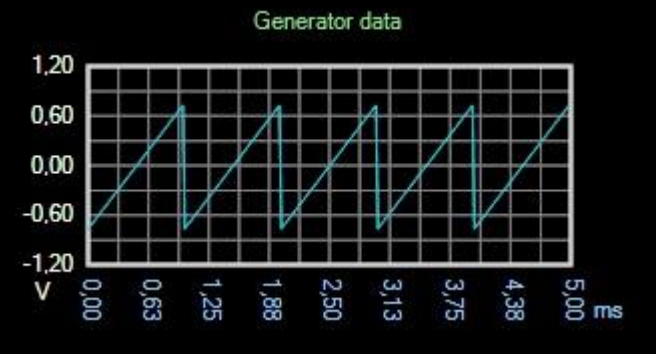
Waveforms	Description	Example
Sine	Sine waveform, suitable e.g. for RMS and THD	
Square	Rectangular waveform, suitable e.g. to study the slope	
Triangle	Triangular waveform, suitable e.g. for modulation	
SawPos	Sawtooth waveform (with a rising curve), suitable e.g. for modulation	

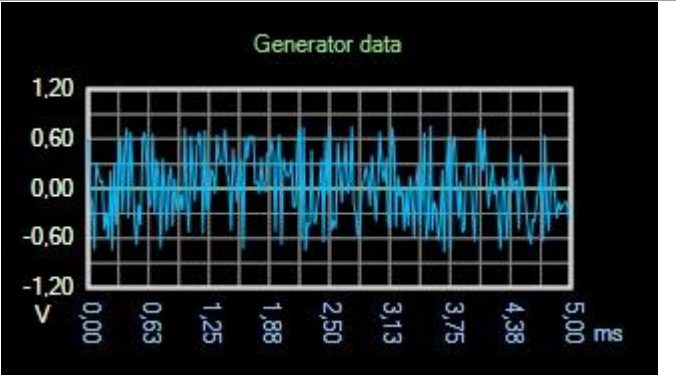
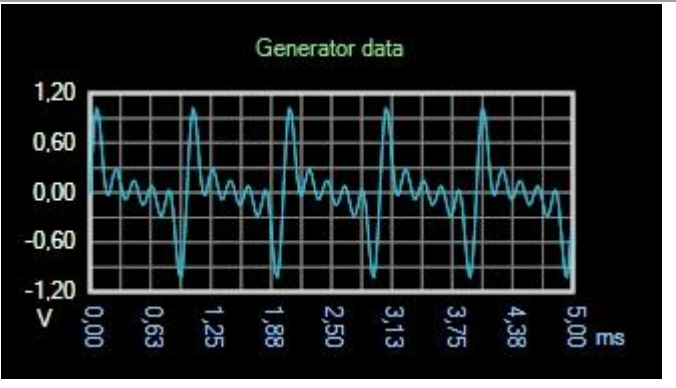
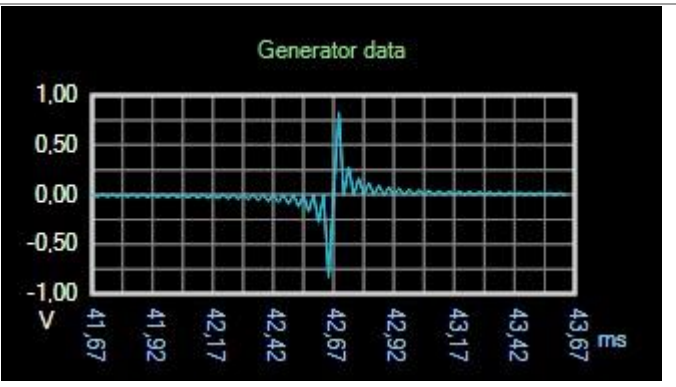
<p>SawNeg</p>	<p>Sawtooth waveform (with falling history), suitable e.g. for modulation</p>	 <p>The graph shows a sawtooth waveform with a falling history. The y-axis is labeled 'V' and ranges from -1.20 to 1.20. The x-axis is labeled 'ms' and ranges from 0.00 to 5.00. The waveform consists of four cycles, each starting at 0.00 V and falling to -1.20 V before jumping back to 0.60 V. The x-axis ticks are 0.00, 0.63, 1.25, 1.88, 2.50, 3.13, 3.75, 4.38, and 5.00.</p>
<p>Noise</p>	<p>Noise, suitable e.g. for simulation of interference</p>	 <p>The graph shows a noise waveform with random fluctuations. The y-axis is labeled 'V' and ranges from -1.20 to 1.20. The x-axis is labeled 'ms' and ranges from 0.00 to 5.00. The waveform is a dense, irregular signal centered around 0.00 V. The x-axis ticks are 0.00, 0.63, 1.25, 1.88, 2.50, 3.13, 3.75, 4.38, and 5.00.</p>
<p>MultiSine</p>	<p>Multi sine (uniform superposition of several sine waveforms), suitable e.g. for the filter test</p>	 <p>The graph shows a multi-sine waveform, which is a complex periodic signal. The y-axis is labeled 'V' and ranges from -1.20 to 1.20. The x-axis is labeled 'ms' and ranges from 0.00 to 5.00. The waveform is a dense, irregular signal centered around 0.00 V. The x-axis ticks are 0.00, 0.63, 1.25, 1.88, 2.50, 3.13, 3.75, 4.38, and 5.00.</p>
<p>Impuls1</p>	<p>Pulse signal, specifically designed for fast frequency and phase response determination within a single measurement cycle. The accuracy increases with increasing sampling rate. The pulse width is determined by the set sampling rate for recording control!</p>	 <p>The graph shows a pulse signal. The y-axis is labeled 'V' and ranges from -1.00 to 1.00. The x-axis is labeled 'ms' and ranges from 41.67 to 43.67. The waveform is a sharp pulse centered around 42.67 ms, with a peak of approximately 0.80 V and a trough of approximately -0.80 V. The x-axis ticks are 41.67, 41.92, 42.17, 42.42, 42.67, 42.92, 43.17, 43.42, and 43.67.</p>

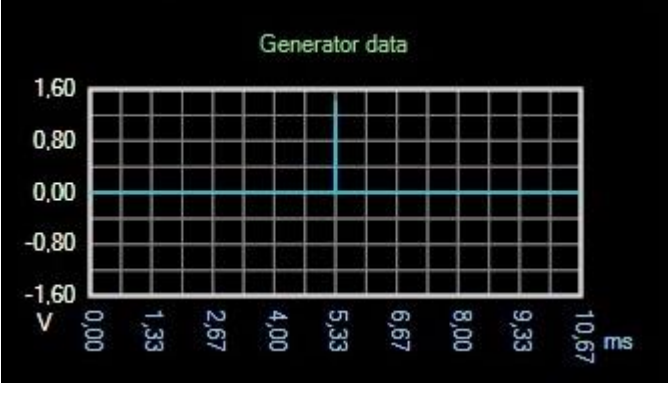
<p>Impuls2</p>	<p>Pulse signal, specifically designed for fast frequency determination within a single measurement cycle. More accurate than Impuls1, but not suited for phase response.</p> <p>The pulse width is determined by the set sampling rate for recording control!</p>	
----------------	---	--

6.6. Modulation Types

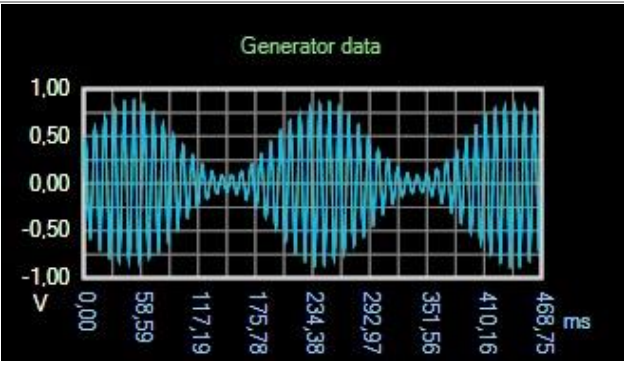
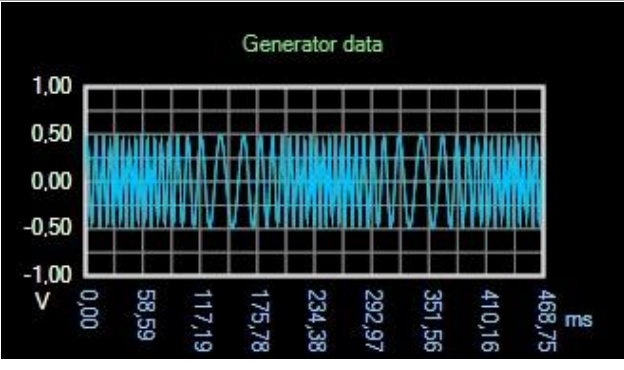
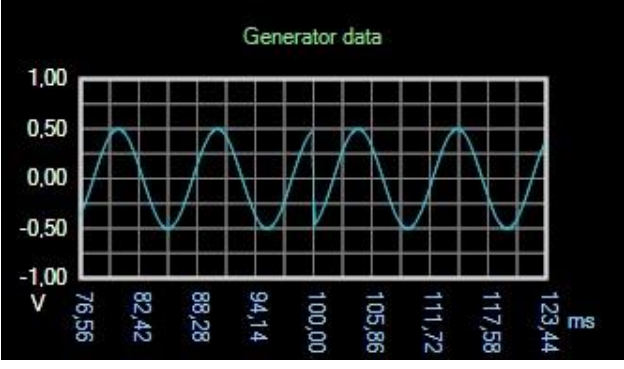
Modulation	Description	Example
AM	Amplitude modulation	
FM	Frequency modulation	
PM	Phase modulation	 <p><i>(Phase modulation by a square wave signal and 180 degrees modulation factor)</i></p>

7. Sweep

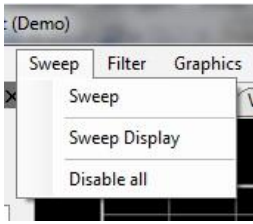

Figure 18: Display Sweep Menu

With help of the sweep, the AudioAnalyzer can create a unique or continuous sweep signal.

7.1. Sweep

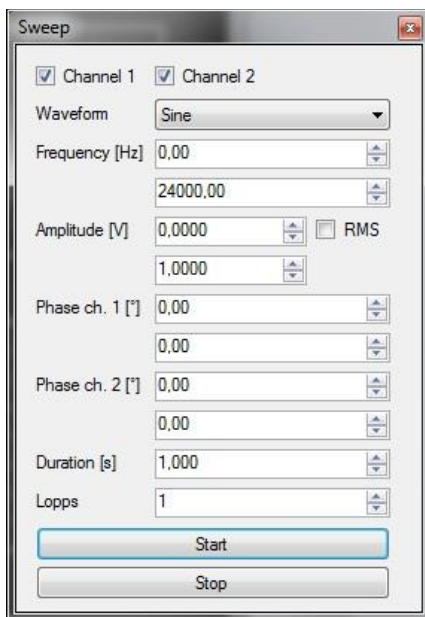

Figure 19: Sweep Menu

The sweep output can be called upon here. The following settings can be made:

- Activation of channels 1 and / or 2
- Waveform (see below)
- Frequency interval
- Amplitude interval
- Identification of whether the amplitude is given as RMS (for sine waveform)
- Phase shift interval for channels 1 and 2
- Duration of the sweep
- Number of sweeps (0 = infinite)

The sweep is started using the start button. An ongoing sweep can be stopped using the stop button.

7.2. Sweep Display

To visualize the sweep produced, a curve output can be called up here.

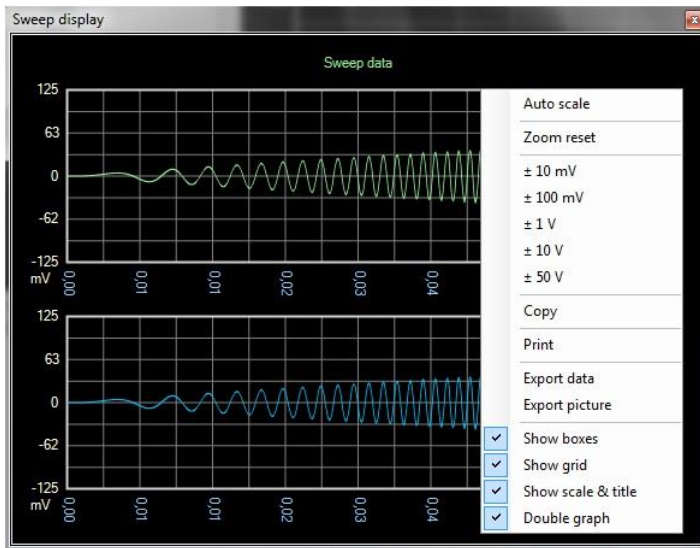

Figure 20: Visualization of the Produced Sweep

In this display, you can enlarge the display by using the left mouse button. Using the right mouse button, a context menu can be activated, in which various settings (see figure) can be made.



Furthermore, the curve data can be printed or exported here.

7.3. Disable All

Turns sweep off.

7.4. Waveforms

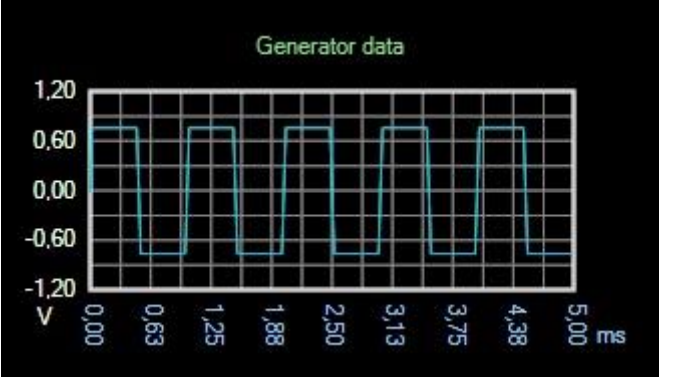
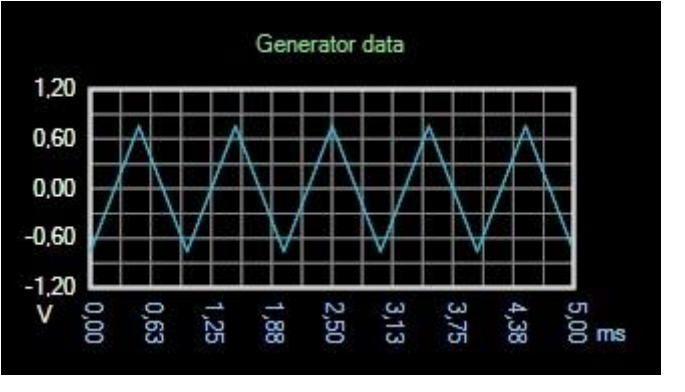
Waveforms	Description	Example
Sine	Sine waveform, suitable e.g. for RMS and THD	

<p>Square</p>	<p>Rectangular waveform, suitable e.g. to study the slope</p>	
<p>Triangle</p>	<p>Triangular waveform, suitable e.g. for modulation</p>	
<p>SawPos</p>	<p>Sawtooth waveform (with a rising curve), suitable e.g. for modulation</p>	
<p>SawNeg</p>	<p>Sawtooth waveform (with falling history), suitable e.g. for modulation</p>	

8. Filter

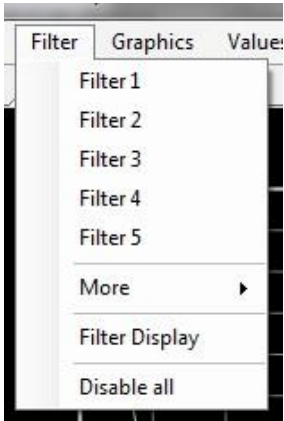

Figure 21: Filter

With the help of the filter the input signal can be recycled before the signal analysis. There are up to five filters. The filters are connected "in series".

8.1. Filter 1 to 5

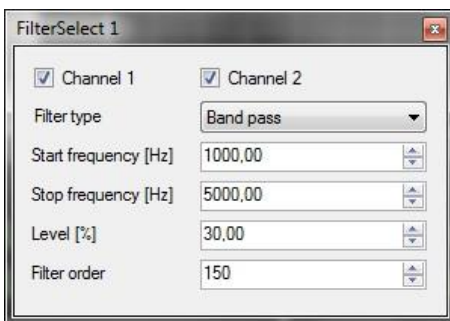

Figure 22: Filter Settings

Here, filters 1 to 5 can be called directly. The following settings are available:

- Activation of channels 1 and / or 2
- Type of filter (high pass, low pass, band pass and band reject)
- Start and stop frequency for bandpass and bandstop
- Cut - off frequency for high - and low - pass
- Gain / Attenuation
- Filter order

Note that the filter order has effect on all filters. It always uses the highest set filter order for the entire filtering. A high filter order generally leads to steeper slopes at the boundary frequencies but requires more processing power. Too high filter order leads to an "overshoot" at the cutoff frequencies.

8.2. More

Here you can access filters 6 to 10.

8.3. Filter Display

To visualize the frequency response of the set filtering, a curve output can be called up here.

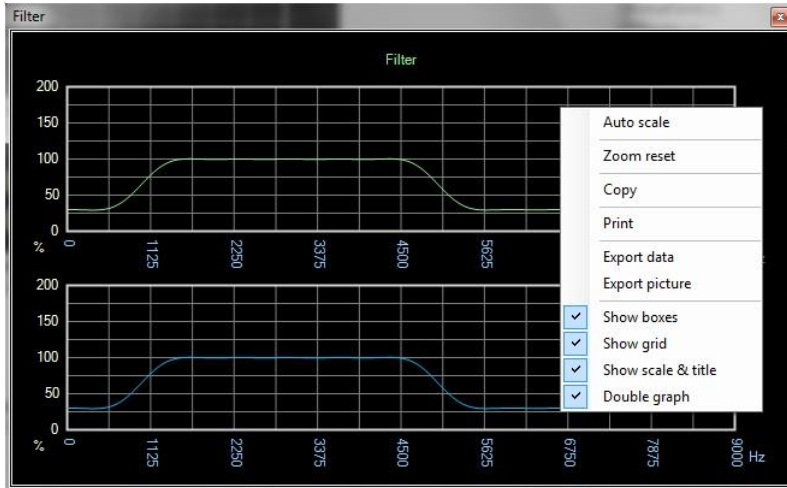

Figure 23: Filter Display

In this display, you can enlarge the display by using the left mouse button. Using the right mouse button, a context menu can be activated, in which various settings (see figure) can be made.

Furthermore, the curve data can be printed or exported here.

8.4. Disable All

Turns all filters off.

9. Visualization

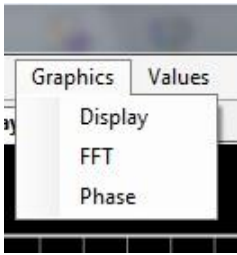

Figure 24: Graphics

Different showings for display can be called up here. For all displays, using the left mouse button can increase the display. Using the right mouse button, a context menu can be activated, in which various settings (see illustrations) can be made.

Furthermore, the curve data can be printed or exported here.

9.1. Live Display

To visualize the actual input signal, the user can call up an output curve.

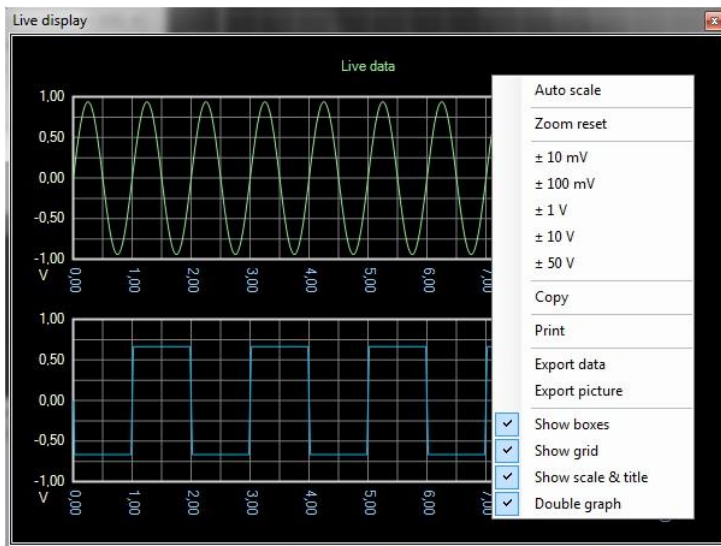

Figure 25: Live Display

9.2. FFT

For visualization of the frequency spectrum, the user can call up an output curve.

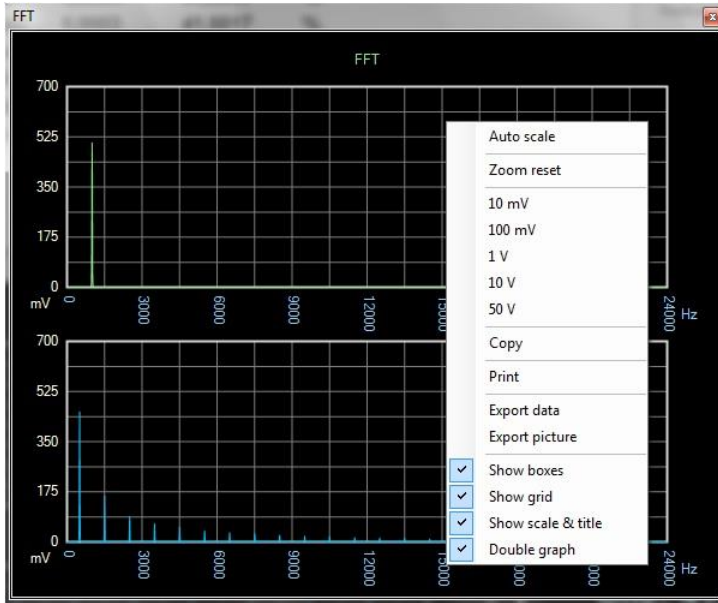

Figure 26: Visualization of FFT

9.3. Phase

For visualization of the phase response, the user can call up an output curve.

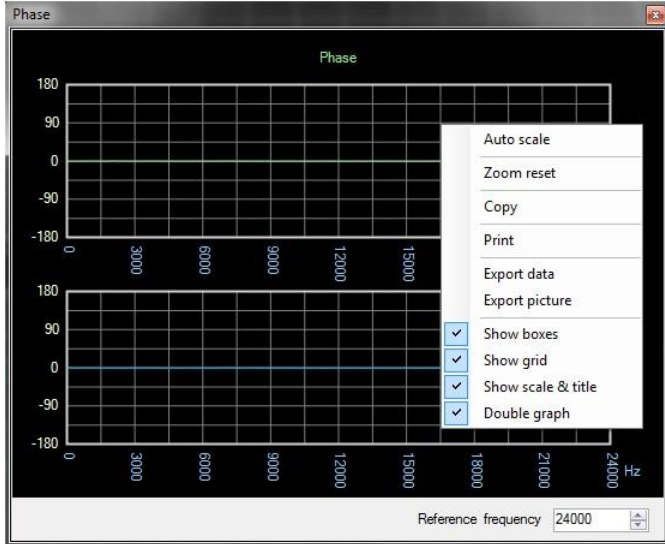

Figure 27: Visualization of Phase Response

For synchronizing the display, user can additionally choose a reference frequency. In the next step a phase transition of zero for the specified reference frequency is assumed.

10. Measurement Values

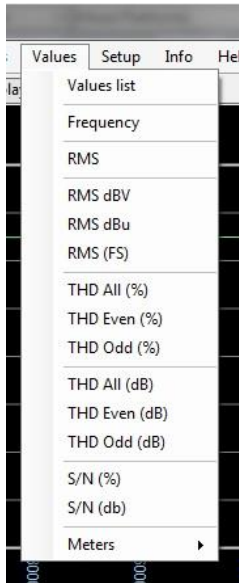

Figure 28: Measurement Values

To display the measured values, user can either call up a tabular list of all the measured values or show each measured value in freely positionable windows.

10.1. Values List

Display of a tabular list of all measurement values.

Value	Channel 1	Channel 2	Unit
RMS	665,14	665,14	mV
RMS	-3,54	-3,54	dBV
RMS	-1,32	-1,32	dBu
Frequency	1000,00	1000,00	Hz
THD All	0,0004	0,0004	%
THD Odd	0,0003	0,0003	%
THD Even	0,0003	0,0003	%
THD All	-107,86	-108,14	dB
THD Odd	-111,3134	-111,7101	dB
THD Even	-110,47	-110,66	dB
PtoP	0,9407	0,9407	abs
PtoP	940,70	940,69	mV
RMS	0,6651	0,6651	FS
S/N	14923,242...	14923,315...	%
S/N	43,48	43,48	dB
RMS Base	665,13	665,13	mV
RMS Base	-3,54	-3,54	dBV
RMS Base	-1,32	-1,32	dBu

Figure 29: Tabular List of All Measurement Values

10.2. Frequency, RMS, THD, SN



Figure 30: Display Frequencies

Activates the displaying of the current measurement values in a separate window.

10.3. RMS - Meter

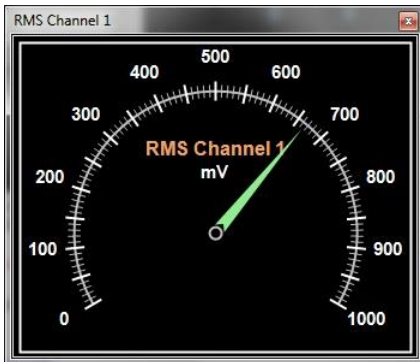

Figure 31: RMS - Meter

The current RMS value can be further displayed in the form of a pointer instrument.

11. Setup

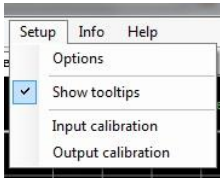

Figure 32: Setup Menu

Here, the configuration and calibration of the AudioAnalyzer takes place.

11.1. Options

The settings of the window title for the AudioAnalyzer are in the *General* category.

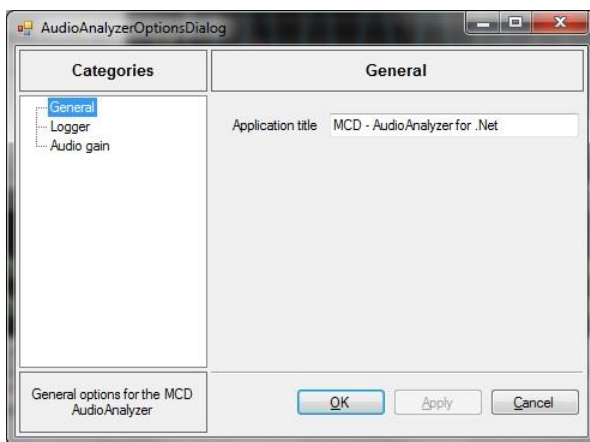

Figure 33: Option *General*

In the *Logging* category, user sees the configuration of the log levels (Error, Warning, Info, Debug, Trace), the turning on of the background updates during logging, even if the log window is not active and the determination of whether or not the log messages should be written in a file.

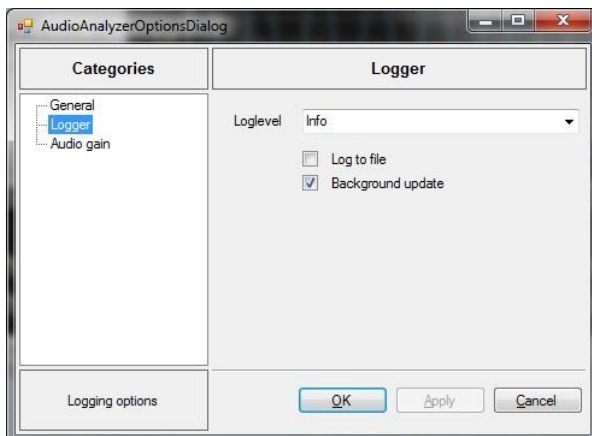

Figure 34: Option *Logger*

If, for the case of input matching, an Audio Gain Controller of the company MCD Elektronik is connected between the signal source and sound card, then the configuration of the communication to the Audio Gain Controller can take place at the *Audio gain* category.

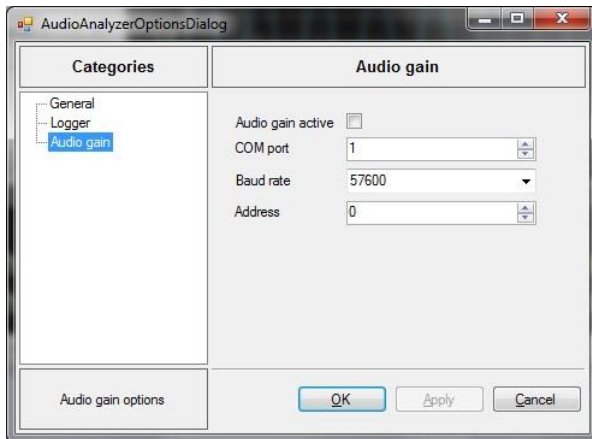

Figure 35: Option *Audio Gain*

11.2. Show Tooltips

This switch determines whether tooltips are displayed while using the AudioAnalyzer.

11.3. Input Calibration

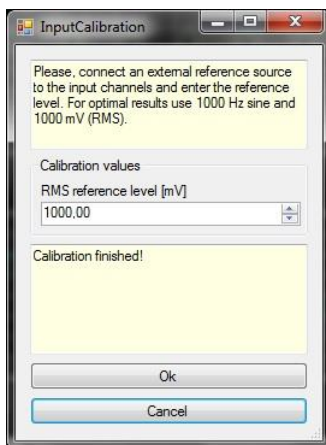

Figure 36: Input Calibration

This dialog displays the currently selected input can be calibrated using a reference source. It should be noted that the AudioAnalyzer must be run as **Administrator** for the storage of calibration values.

11.4. Output Calibration

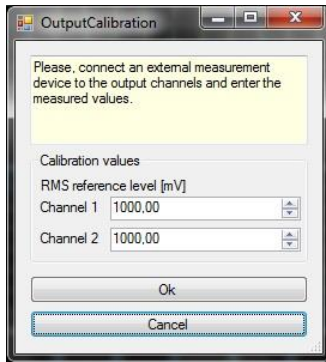

Figure 37: Output Calibration

This dialog displays the currently selected output can be calibrated using a reference source. It should be noted that the AudioAnalyzer must be run as **Administrator** for the storage of calibration values.

12. COM / DCOM Interface



Figure 38: COM / DCOM Interface

With the help of **COM / DCOM interface**, the AudioAnalyzer can be remotely controlled via each COM / DCOM enabled Windows® program.

12.1. Class Name

The AudioAnalyzer is accessed through the following COM / DCOM class:

"MCD.AudioAnalyzerServer.Interface"

12.2. General Control Commands

Command / Property	Description
Reset()	All settings set to predefined values (except display).
Close()	Closes the AudioAnalyzer. No more commands are executed.
ShowNormal()	Displays the AudioAnalyzer in its original size.
Minimize()	Minimizes the AudioAnalyzer.
Maximize()	Maximizes the AudioAnalyzer.
Activate()	Enables the AudioAnalyzer as the active window.
LoadPreset(sPreset)	Loading a saved configuration of the AudioAnalyzer. The appropriate file name (and

	path) must be specified in <i>sPreset</i> .
TopMost	Identifies the AudioAnalyzer as Topmost - window (true / false).
WaitReset	Reset the synchronization event for the wait function.
Wait	Wait for new reading.
RemoteMode	Remote mode of the AudioAnalyzer <ul style="list-style-type: none"> • -1: Automatic • 0: Operator • 1: Master • 2: Administrator • 3: MCD • 4: Developers
Title	Window title of the AudioAnalyzer.

12.3. Recording Control

Command / Property	Description
InputMixerDevice	Select the recording source (sound card)
InputMixerLine	Select the input of the sound card
InputBufferSize	Size of the receiving buffer in samples
InputSampleRate	Sampling rate for recording in Hz
InputBitsPerSample	Resolution for inclusion in bits (8 / 16 / 24 / 32)
InputRun	Indicates whether recording is active (true / false)
IsInputCalibrated	Indicates whether the receiving channel used is calibrated (true / false)
OutputRun	Indicates whether playback is active (true / false)
IsOutputCalibrated	Indicates whether the reproduction channel used is calibrated (true / false)
FFTWindowType	Specifies the window function, which for the FFT analysis is used (none, Hanning)

12.4. Audio Gain

Command / Property	Description
AudioGainActive	Status of the Audio Gain Box
AudioGainCOMPort	Selection of the COM port for the Audio Gain Box
AudioGainBaudrate	Selection of baud rate for the Audio Gain Box
AudioGainAddress	Selection of the address for the Audio Gain Box
AudioGainCh1	Selection of measuring range channel for channel 1 0: disabled 1: 10 mV 2: 100 mV 3: 1 V 4: 10 V 5: 50 V
AudioGainCh2	Selection of measuring range channel for channel 2 0: disabled 1: 10 mV 2: 100 mV 3: 1 V 4: 10 V 5: 50 V
OutputGainCh1	Selection of the output gain for channel 1
OutputGainCh2	Selection of the output gain for channel 2

12.5. Playback Control

Command / Property	Description
OutputMixerDevice	Select the playback device (sound card)
OutputMixerLine	Selection of the output of the sound card (only for calibration values relevant, the output is always on all outputs)
OutputSampleRate	Sampling rate for playback in <i>Hz</i>
OutputBitsPerSample	Resolution for playback in <i>bits</i> (8 / 16 / 24 / 32)

12.6. Generators

Command / Property	Description
Generator<n>ActiveCh1	Activates channel 1
Generator<n>ActiveCh2	Activates channel 2
Generator<n>WaveForm	Sets the waveform
Generator<n>Frequency	Frequency in <i>Hz</i>
Generator<n>FrequencyStart	Start frequency for multi - sine wave in <i>Hz</i>
Generator<n>FrequencyStop	Stop frequency for multi - sine wave in <i>Hz</i>
Generator<n>FrequencyStep	Increment for multi - sine wave in <i>Hz</i>
Generator<n>AmplitudeVolt	Amplitude value (peak) in <i>Volt</i>
Generator<n>AmplitudeRMS	Amplitude value than RMS value (only for sine waveform) in <i>Volt</i>
Generator<n>PhaseCh1	Phase shift for channel 1 in <i>degrees</i>
Generator<n>PhaseCh2	Phase shift for channel 2 in <i>degrees</i>
Generator<n>ModulationForm	Modulation shape, when this generator is used to modulate a subsequent generator
Generator<n>ModulationIndex	The generator to be modulated

<n> = 1..10

For indexing of the generators several ways are possible:

Generator1ActiveCh1

Generator1.ActiveCh1

Generator (1).ActiveCh1

12.7. Sweep

Command / Property	Description
SweepActiveCh1	Activates channel 1
SweepActiveCh2	Activates channel 2
SweepWaveForm	Sets the waveform
SweepFrequencyStart	Start frequency in <i>Hz</i>
SweepFrequencyStop	Stop frequency in <i>Hz</i>
SweepAmplitudeStart	Start amplitude (top) in <i>Volt</i>
SweepAmplitudeStop	Stop amplitude (top) in <i>Volt</i>
SweepAmplitudeStartRMS	Start amplitude as RMS value (only for sine waveform) in <i>Volt</i>
SweepAmplitudeStopRMS	Stop amplitude as RMS value (only for sine waveform) in <i>Volt</i>
SweepPhaseStartCh1	Start phase shift for channel 1 in <i>degrees</i>
SweepPhaseStopCh1	Stop phase shift for channel 1 in <i>degrees</i>
SweepPhaseStartCh2	Start phase shift for channel 2 in <i>degrees</i>
SweepPhaseStopCh2	Stop phase shift for channel 2 in <i>degrees</i>
SweepDuration	Duration of sweep in <i>seconds</i>
SweepLoops	Number of passes for the sweep (0 = infinite)
StartSweep()	Start sweep
StopSweep()	Stop sweep

12.8. Filter

Command / Property	Description
AllFiltersOff()	Turns off all filters
Filter<n>ActiveCh1	Enables channel 1
Filter<n>ActiveCh2	Enables channel 2
Filter<n>FilterType	Filter type
Filter<n>FrequencyStart	Start or cut - off frequency
Filter<n>FrequencyStop	Stop frequency
Filter<n>FilterOrder	Filter order
Filter<n>FilterLevel	Gain / attenuation <i>absolutely</i>

<n> = 1..10

For indexing of the sweeps several ways are possible:

Filter1ActiveCh1

Filter1.ActiveCh1

Filter(1).ActiveCh1

12.9. Measurement Values

Command / Property	Description
RMSCh1	RMS for channel 1 in <i>Volt</i>
RMSCh2	RMS for channel 2 in <i>Volt</i>
RMSDBUCh1	RMS for channel 1 in <i>dBu</i>
RMSDBUCh2	RMS for channel 2 in <i>dBu</i>
RMSDBVCh1	RMS for channel 1 in <i>dBV</i>
RMSDBVCh2	RMS for channel 2 in <i>dBV</i>
FSCh1	FS for channel 1
FSCh2	FS for channel 2
FSDBCh1	FS for channel 1 in <i>dB</i>
FSDBCh2	FS for channel 2 in <i>dB</i>
RMSBaseCh1	RMS the base frequency for channel 1 in <i>Volt</i>
RMSBaseCh2	RMS the base frequency for channel 2 in <i>Volt</i>
RMSBaseDBUCh1	RMS the base frequency for channel 1 in <i>dBu</i>
RMSBaseDBUCh2	RMS the base frequency for channel 2 in <i>dBu</i>
RMSBaseDBVCh1	RMS the base frequency for channel 1 in <i>dBV</i>
RMSBaseDBVCh2	RMS the base frequency for channel 2 in <i>dBV</i>
FrequencyCh1	Frequency for channel 1 in <i>Hz</i>
FrequencyCh2	Frequency for channel 2 in <i>Hz</i>
THDAICh1	THD for channel 1 <i>absolut</i>
THDAICh2	THD for channel 2 <i>absolut</i>
THDAIDBCh1	THD for channel 1 in <i>dB</i>
THDAIDBCh2	THD for channel 2 in <i>dB</i>

THDOddCh1	THD all odd harmonics for channel 1 <i>absolute</i>
THDOddCh2	THD all odd harmonics for channel 2 <i>absolute</i>
THDOddDBCh1	THD all odd harmonics for channel 1 in <i>dB</i>
THDOddDBCh2	THD all odd harmonics for channel 2 in <i>dB</i>
THDEvenCh1	THD all even harmonics for channel 1 <i>absolute</i>
THDEvenCh2	THD all even harmonics for channel 2 <i>absolute</i>
THDEvenDBCh1	THD all even harmonics for channel 1 in <i>dB</i>
THDEvenDBCh2	THD all even harmonics for channel 2 in <i>dB</i>
SNADDBCh1	Signal / noise ratio for channel 1 incl. THD in <i>dB</i>
SNADDBCh2	Signal / noise ratio incl. THD for channel 2 in <i>dB</i>
PtoPCh1	Peak to peak value for channel 1 in <i>Volt</i>
PtoPCh2	Peak to peak value for channel 2 in <i>Volt</i>
PtoPAbsCh1	Peak to peak value uncalibrated for channel 1 in <i>Volt</i>
PtoPAbsCh2	Peak to peak value uncalibrated for channel 2 in <i>Volt</i>
SNDBCh1	Signal / noise ratio for channel 1 in <i>dB</i>
SNDBCh2	Signal / noise ratio for channel 2 in <i>dB</i>
DataCh1	Array containing all samples from the last measurement for channel 1
DataCh2	Array containing all samples from the last measurement for channel 2
FFTCh1	Array with FFT analysis of the last measurement for channel 1
FFTCh2	Array with FFT analysis of the last measurement for channel 2

All commands must exist in a version for maintenance and reading out of stable measurement values.

Command / Property	Description
StabData<command>(Reading out a stable value
iCount,	Number of measurements, for which the values must be stable
iMaxCount,	Number of maximum measurements before is canceled
rTolerance,	Maximal allowable tolerance
rMin,	Minimum value
rMax,	Maximum value
bUseAva	Return of the last or average value of measurement series
)	

13. Technical Data

13.1. General Notes

The AudioAnalyzer is used for stimulation and analysis of audio signals. Periodic audio signals (e.g. sine wave) as well as continuous audio streams can be put out and read digital and analog.

For this, the following connections are available:

Input		Output
Analog XLR (Input Ranges 1 mVrms to 50 Vrms)		Analog XLR (Input Ranges 1 mVrms to 15 Vrms)
Digital optical S / PDIF to 192 kSps		Digital optical S / PDIF to 192 kSps
Digital electrical S / PDIF to 192 kSps		Digital electrical S / PDIF to 192 kSps
USB 2.0 High Speed		USB 2.0 High Speed

Field of Application:

- Calibration and verification of analog and digital sound systems
- Implementation of audio analog ↔ digital
- Implementation of S / PDIF optical ↔ electrical

13.2. Technical Data in Detail

13.2.1. Wiring and LED Indicators



Status	Select
Green LED: USB	Yellow LED: Input for AudioAnalyzer
Red LED: Error	Yellow LED: Source Analog Output

LED input for AudioAnalyzer (yellow): Shows the selected source for the AudioAnalyzer (USB).

Display	Definition
Permanently lit	Analog input is chosen as source
Blinks slowly	S / PDIF is chosen as source (electrical or optical)
Off	Invalid

LED source analog output (yellow): Indicates the selected source for the analog output.

Display	Definition
Permanently lit	Generator (USB) is chosen as source
Blinks slowly	S / PDIF is chosen as source (electrical or optical)
Off	Analog input is chosen as source or output is mute

USB LED (green): Provides information on the status of the USB connection.

Display	Definition
Permanently lit	USB connection is established; no data traffic
Blinks slowly	USB cable is connected, but no driver is loaded
Blinks fast	USB connection is established; data is exchanged with the PC
Off	No USB connection

Error LED (red): Indicates invalid or missing audio signals.

Display	Definition
Lit	<ul style="list-style-type: none"> • If S / PDIF is chosen as source for the AudioAnalyzer: S / PDIF signal is invalid or does not exist or • If the analog input is selected as the source for the AudioAnalyzer: input signal is overloaded / too big
Blinks slowly	<ul style="list-style-type: none"> • If S / PDIF is selected as the source for the analog output: S / PDIF signal is invalid or does not exist
Off	No error on the used sources

13.2.2. Block Diagram of Signal Paths

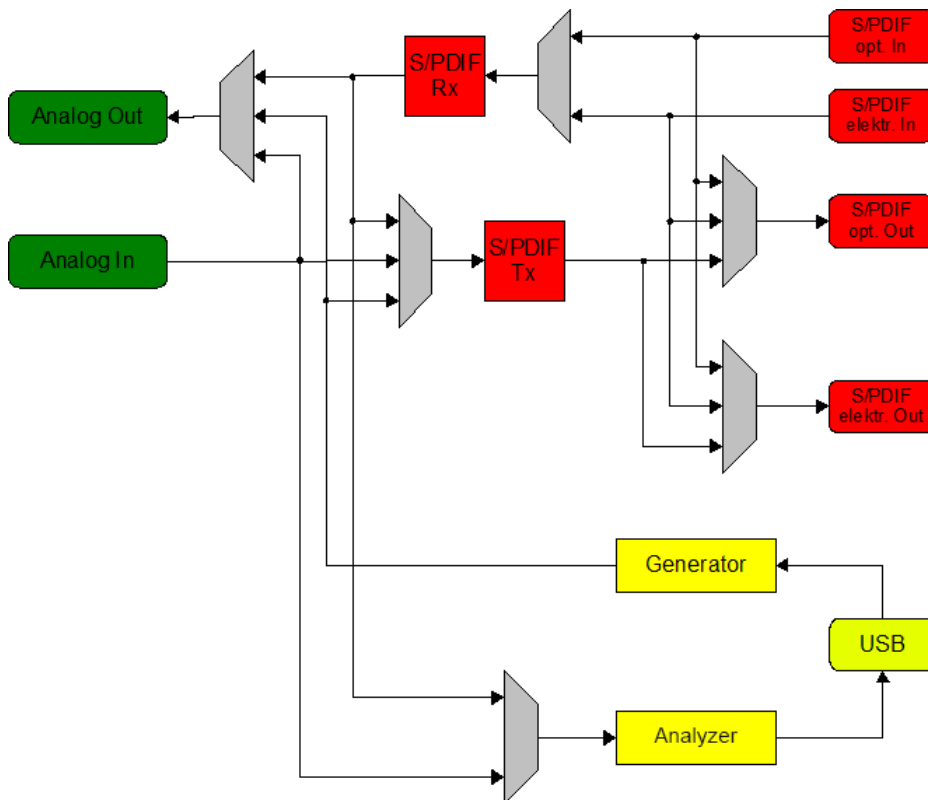

Figure 39: Block Diagram

13.2.3. Electrical and Mechanical Properties

General		
S / PDIF - Interface	DIX9211	
ADW	CS5381	
DAW	PCM1792A	

General Electronical Features		
Supply voltage	100 - 240 VAC 50 / 60 Hz	
Current consumption for operation	Max. 650 mA	Type 50 mA / 230 V

Mechanical Features		
Dimensions (length x width x height)	250 mm x 350 mm x 44 mm	Without connectors, front panel and device base
Connectors	USB - B	
	2 x TOSLINK [®] compatible connection	Optical S / PDIF input and output
	1 x Cinch socket white	Electrical S / PDIF input
	1 x Cinch socket black	Electrical S / PDIF output
	2 x XLR socket	Analog input
	2 x XLR socket	Analog output
	Cold device plug	Power supply
Gewicht ohne Zubehör	2,1 kg (4.6 lb)	

Features Analog Input (Line In)		
Input impedance	DC differential 10 MOhm	AC measurement
	DC differential 200 kOhm	DC measurement
	DC counter signal mass 100 kOhm	DC measurement
	AC differential 200 kOhm	AC and DC measurement
	AC counter signal mass 100 kOhm	AC and DC measurement
Maximum input voltage DC	± 50 V counter signal mass	AC measurement
	± 100 V differential	AC measurement
	± 20 V counter signal mass	DC measurement up to 2 V range
	± 50 V counter signal mass	DC measurement above 4 V range
Measurement area analog in (symmetrical)	10 mVrms, 20m Vrms, 40 mVrms, 50 mVrms	Left and right separately adjustable
	100 mVrms, 200 mVrms, 400 mVrms, 500 mVrms	
	1 Vrms, 2 Vrms, 4 Vrms, 5 Vrms	
	10 Vrms, 20 Vrms, 40 Vrms, 50 Vrms	Maximum measurable voltage (AC + DC)
Maximum measurable peak voltage (AC + DC)	± 35 V	Counter signal mass in the DC measuring range
Level deviation at 1 kHz	Up to 100 mVrms: < 1 % of measurement range	
	As of 200 mVrms: < 0,2 % of measurement range	
	As of 400 mVrms: < 0,1 % of measurement range	
Distortion at 1 kHz (symmetrical)	10 mVrms:< 0,02 %	
	As of 20 mVrms: < 0,01 %	
	As of 50 mVrms< 0,005 %	
	As of 200 mVrms < 0,002%	Typically < 0,001 %
Sample rate	44,1 kHz, 48 kHz, 96 kHz, 192 kHz	
Resolution	24 Bit nominal	

In Connection with AudioAnalyzer.Net		
Measurement frequency	20 Hz up to 96 kHz	Maximum of up to half the sample frequency
Measurement THD (odd, even, all)	50 Hz up to 48 kHz	Maximum to ¼ of the sample frequency
Filter types	High pass, low pass, band pass, band stop	Start and stop frequencies in the frequency range can be chosen freely
Filter order	3 to 500	
Level subsidence / increase	0 % to 200 %	
Measurement level	AC, DC, RMS base, RMS total, Peak - to - Peak	
Measurement noise	S / N, SINAD	
Measurements FFT	AC, DC, RMS, Noise (- THD), Noise (+ THD)	

Features Analog Output (Line Out)		
Output impedance	50 Ohm	
Signal range analog out	10 mVrms, 20 mVrms, 40 mVrms, 50 mVrms	Left and right separately adjustable
	100 mVrms, 200 mVrms, 400 mVrms, 500 mVrms	
	1 Vrms, 2 Vrms, 4 Vrms, 5 Vrms	
	10 Vrms, 15 Vrms	Maximum 8 Vrms asymmetrical
Level deviation at 1 kHz on 200 kOhm	10 mVrms: < 1 % of measurement range	In asymmetric mode in addition to 0.5 % of the set value
	20...50 mVrms: < 0,5 % of measurement range	
	Up to 100 mVrms: < 0,1 % of measurement range	
Distortion at 1 kHz (symmetric)	10 mVrms: < 0,1 %	Typically < 0,05 %
	20...50 mVrms: < 0,05 %	Typically < 0,01 %
	ab 100 mVrms: < 0,01 %	Typically < 0,005 %
Sample rate	44,1 kHz, 48 kHz, 96 kHz, 192 kHz	
Resolution	24 Bit	
In Connection with AudioAnalyzer.Net		
Output signal form	Sine, Triangle, Saw tooth positive, Saw tooth negative, Noise, Impulse, Multi sine	
Frequency range	20 Hz to 96 kHz	Maximum up to half the sample frequency in 50 Hz steps adjustable
Modulation types	Amplitude modulation, frequency modulation, phase modulation	

Digital Features		
Activation	USB 2.0 High Speed	Galvanic isolation
Input impedance of electrical input S / PDIF	75 Ohm	Asymmetric; min. 0,2 Vpp; max. 3,3 V
Output level electrical output S / PDIF	0,5 Vpp at 75 Ohm terminating resistor	Asymmetric; ca. 1 Vpp without terminating resistor
Sample rates S / PDIF	8kHz ... 192 kHz	
Sample rates generator / analog input	44,1kHz / 48kHz / 96kHz / 192kHz	
Resolution	24 Bit	
Size of the read buffer AudioAnalyzer	2048 Samples	
Size of the output buffer generator	2048 Samples	
Optical indicators at the back side	LED yellow LED green LED red	Optical input selected Electrical input selected USB connected and operational Input signal error S / PDIF Overload analog input (e.g. no signal)
Optical indicators on the front	LED red	Power indicator

13.3. Interface Description

13.3.1. Set of Commands

13.3.1.1. General Establishment

Baud rate: arbitrary, 8 bit data, 1 Stop, no parity, no HW handshake.

Start character is sent as \$12.

Length byte is the number of transmitted ASCII characters (Char) starting with the CMD byte.

As the end and termination sign \$ 0D is sent.

General Command Standard Syntax

Command: „?“ corresponds to ASCII signs

<i>Data</i>	<i>Parameter</i>	<i>Description</i>	<i>Value</i>	<i>Value Range</i>	<i>Information</i>
\$12	Trig.	Trigger sign			Trigger sign for interface
??	LENbyte	Lengths byte [u08]		2..255	Number of ASCII signs beginning with CMD byte to data byte n
??	CMDbyte	Command code [u08]			Command code see command
??	Dbyte1				
\$0D	Term.	Termination			End sign

General Response: Standard Syntax**Response: with correct command parameters**

<i>Data</i>	<i>Parameter</i>	<i>Description</i>	<i>Value</i>	<i>Value Range</i>	<i>Information</i>
\$12	Trig.	Trigger sign			Trigger sign for interface
??	CMDbyte	Command code [u08]			Repetition of the command code in the response
??	Dbyte1				
\$0D	Term.	Termination			End sign

Response: with error in command parameters

<i>Data</i>	<i>Parameter</i>	<i>Description</i>	<i>Value</i>	<i>Value Range</i>	<i>Information</i>
\$12	Trig.	Trigger sign			Trigger sign for interface
FF	CMDbyte	ERROR [u08]			Default „FF“ for error
??	Error byte	Errorcode [u08]			Error code
\$0D	Term.	Termination			End sign

13.3.1.2. Maximum Data Length of Transmission

For commands with no fixed length, no more than **127 bytes of data** (254 ASCII signs high byte / low byte) can follow the command byte (CMDbyte).

Exceptions are commands with audio data (command 50 and 61). Upon completion of the command string the audio user data is transmitted in binary form.

Type Definitions:

<i>Data Type</i>	<i>Abbreviation</i>
unsigned char	u08
signed char	s08
unsigned short	u16
signed short	s16
unsigned long	u32
signed long	s32
float	f32

ERROR Codes:

<i>Data Type</i>	<i>Abbreviation</i>
ERROR	0x0F
NOERROR	0x00
NOCMD	0x01
SYNTAX	0x02
PARAMS	0x03
VALUERANGE	0x04
CMDLEN	0x05
CHECKSUM	0x06
TIMEOUT	0x07

13.3.2. Command Implementation for Different Software Versions

Command	Description	SW Version			
		1.00	1.20		
20	Writing / reading configuration memory	X	X		
2F	Unlock configuration memory	X	X		
3F	Retrieving software version	X	X		
50	Recording audio data (Packet / Continuous Packet / Stream)	X	X		
51	Selecting input sources and its sample rates	X	X		
53	Selecting analog range	X	X ¹⁾		
60	Generator or streaming operation	X	X ¹⁾		
61	Output audio data (stream / generator)	X	X		
74	Read status	X	X		
75	Self - test mode on / off	X	X		
80	Write calibration values	X	X		
81	Read calibration values	X	X		
82	Save calibration values	X	X		
83	Load calibration values	X	X		
84	Save startup - configuration	X	X		

¹⁾ Command modified

13.3.2.1. Command 20 Writing / Reading Configuration Memory

This command is only for firmware updates and should never be used in normal operation! If the memory is locked, then the error code FF04 is returned.

Command:

<i>Data</i>	<i>Parameter</i>	<i>Description</i>	<i>Value</i>	<i>Value Range</i>	<i>Information</i>
\$12	Trig.	Trigger sign			
??	LENbyte	Length byte [u08]		2..255	
20	CMDbyte	Comamnd code [u08]			
??	Dbyte 1	DATA [u08]		0..255 = 00h..FFh	Data to be send
??	...	DATA [u08]		0..255 = 00h..FFh	
??	Dbyte x	DATA [u08]		0..255 = 00h..FFh	
\$0D	Term.	Termination			

Response:

<i>Data</i>	<i>Parameter</i>	<i>Description</i>	<i>Value</i>	<i>Value Range</i>	<i>Information</i>
\$12	Trig.	Trigger sign			
20	CMDbyte	Command code			
??	Dbyte 1	DATA [u08]		0..255 = 00h..FFh	Read data
??	...	DATA [u08]		0..255 = 00h..FFh	
??	Dbyte x	DATA [u08]		0..255 = 00h..FFh	
\$0D	Term.	Termination			

13.3.2.2. Command 2F Unlocking Configuration Memory

Unlocks access to the configuration memory. Any other command except command 20 blocks the access again.

Command:

<i>Data</i>	<i>Parameter</i>	<i>Description</i>	<i>Value</i>	<i>Value Range</i>	<i>Information</i>
\$12	Trig.	Trigger sign			
04	LENbyte	Length byte [u08]		2..255	
2F	CMDbyte	Comand code [u08]			
??	Dbyte	DATA [u08]		0..255 = 00h..FFh	55h = Configuration memory unlocked Any other value will lock the memory
\$0D	Term.	Termination			

Response:

Data	Parameter	Description	Value	Value Range	Information
\$12	Trig.	Trigger sign			
2F	CMDbyte	Command code			
\$0D	Term.	Termination			

13.3.2.3. Command 3F Reading SW Version Firmware**Command:**

Data	Parameter	Description	Value	Value Range	Information
\$12	Trig.	Trigger sign			
02	LENbyte	Length byte [u08]		2..255	
3F	CMDbyte	Command code [u08]			
\$0D	Term.	Termination			

Response:

Data	Parameter	Description	Value	Value Range	Information
\$12	Trig.	Trigger sign			
3F	CMDbyte	Command code			
??	Dbyte 1	DATA [u08]			Textstring of the version
??	...	DATA [u08]			
??	Dbyte x	DATA [u08]			
\$0D	Term.	Termination			

13.3.2.4. Command 50 Recording Audio Data

Returns the currently applied audio data. The data is not transmitted as ASCII hex signs, rather than binary data. Hereby, two modes can be selected:

Simple:

Up to 65536 samples will be read and then stop sampling.

Continuous:

As above, but the sampling is not stopped, but the internal buffer further filled and with the next request uses the audio data therefrom. If there is not enough data in the buffer the missing values are collected and sent. So it is always the requested number of samples which are supplied.

At the end there may be an interruption displayed to the S / PDIF input, which is relevant only if the S / PDIF input is selected as the source. If the data is not fast enough collected, then the data that does not fit in the input buffer (2048 samples) are discarded, and displayed is an overflow.

Please note:

When you change from continuous operation to simplicity the first request is still served from the input buffer.

Command:

<i>Data</i>	<i>Parameter</i>	<i>Description</i>	<i>Value</i>	<i>Value Range</i>	<i>Information</i>
\$12	Trig.	Trigger sign			
08	LENbyte	Length byte [u08]		2..255	
50	CMDbyte	Command code [u08]			
??	Dbyte 1	Type of transaction [u08]		0..7 = 00h..07h	0 = simple 1 = continuous
??	Dbyte 2	Number of samples [u16]	highByte	0..255 = 00h..FFh	Number of samples - 1
??	Dbyte 3		lowByte	0..255 = 00h..FFh	
\$0D	Term.	Termination			

Response:

<i>Data</i>	<i>Parameter</i>	<i>Description</i>	<i>Value</i>	<i>Value Range</i>	<i>Information</i>
\$12	Trig.	Trigger sign			
50	CMDbyte	Command code			
\$??	Dbyte 1	First sample left [u24]	highByte	0..255 = 00h..FFh	Audio data (6 bytes per sample)
\$??	Dbyte 2		middleByte	0..255 = 00h..FFh	
\$??	Dbyte 3		lowByte	0..255 = 00h..FFh	
\$??	Dbyte 4	First sample right [u24]	highByte	0..255 = 00h..FFh	
\$??	Dbyte 5		middleByte	0..255 = 00h..FFh	
\$??	Dbyte 6		lowByte	0..255 = 00h..FFh	
...					
\$??	Dbyte	n - th sample right [u24]	highByte	0..255 = 00h..FFh	
\$??	Dbyte		middleByte	0..255 = 00h..FFh	
\$??	Dbyte		lowByte	0..255 = 00h..FFh	

??	Dbyte	Status [u08]		0..255 = 00h..FFh	Bit 0 = 1 → Connection to S / PDIF was interrupted Bit 1 = 1 → Buffer overflow Bit 2 = 1 → Not used Bit 3 = 1 → Not used Bit 4 = 1 → Left analog channel overdriven Bit 5 = 1 → Right analog channel overdriven Bit 6 = 1 → Not used Bit 7 = 1 → Not used
\$0D	Term.	Termination			

13.3.2.5. Command 51 Selecting Input Source and Sample Rate

Assigns the signal sinks (analog output, AudioAnalyzer (USB output) and S / PDIF output) to their source. The two S / PDIF outputs cannot simultaneously have the analog input and the generator as a source. Likewise, it is not possible to assign the analog output to the analog input, while the self - test mode is active (because of feedback).

Is for the analog output and the AudioAnalyzer S / PDIF selected as the source, then both choose the same input.

The last byte of data sets, with which sample rate the audio generator and the analog input work. The sample rate of the S / PDIF input is determined by the input signal. The sample rates of the signal sinks (analog output, S / PDIF output and AudioAnalyzer) automatically have the sample rate of the respective designated source.

Command:

Data	Parameter	Description	Value	Value Range	Information
\$12	Trig.	Trigger sign			
08	LENbyte	Length byte [u08]		2..255	
51	CMDbyte	Command code [u08]			
??	Dbyte 1	AudioAnalyzer source (USB) Analog output source [u08]		0..255 = 00h..FFh	x0h = Optical S / PDIF input x1h = Electrical S / PDIF input x2h = Analog input 0xh = Optical input 1xh = Electrical input 2xh = Analog input 3xh = Generator (USB) 4xh = Mute
??	Dbyte 2	Source for optical S / PDIF output Source for electrical S / PDIF output [u08]		0..255 = 00h..FFh	x0h = Optical S / PDIF input direct x1h = Electrical S / PDIF input direct x2h = Analog input x3h = Generator (USB) x4h = Mute 0xh = Optical S / PDIF input direct 1xh = Electrical S / PDIF input direct 2xh = Analog input 3xh = Generator (USB) 4xh = Mute

??	Dbyte 3	Sample rate [u08]		0..255 = 00h..FFh	x0h = Audio generator with 44,1 kHz x1h = Audio generator with 48 kHz x2h = Audio generator with 96 kHz x3h = Audio generator with 192 kHz 0xh = Analog input with 44,1 kHz 1xh = Analog input with 48 kHz 2xh = Analog input with 96 kHz 3xh = Analog input with 192 kHz
\$0D	Term.	Termination			

Response:

Data	Parameter	Description	Value	Value Range	Information
\$12	Trig.	Trigger sign			
51	CMDbyte	Command code			
\$0D	Term.	Termination			

13.3.2.6. Command 53 Selecting Analog Ranges

Selects the measurement ranges of the analog input and the maximum signal level of the analog output left and right respectively.

If the ADC offset adjustment is activated, the offset of the input signal is measured and removed directly at the ADC with a digital high - pass filter. The time required for this depends on the sample rate of the ADC (0.52 s at 192 kHz to 2.27 s at 44.1 kHz). This offset adjustment is mandatory when a DC measurement range is changed. If both input channels are AC coupled the offset adjustment is performed continuously.

Parameter Value	Input / Output Range	Parameter Value	Input / Output Range
0	10 mVrms	8	1 Vrms
1	20 mVrms	9	2 Vrms
2	40 mVrms	A	4 Vrms
3	50 mVrms	B	5 Vrms
4	100 mVrms	C	10 Vrms
5	200 mVrms	D	20 Vrms (Input) / 15 Vrms (Output)
6	400 mVrms	E	40 Vrms (Input only)
7	500 mVrms	F	50 Vrms (Input only)

Command:

<i>Data</i>	<i>Parameter</i>	<i>Description</i>	<i>Value</i>	<i>Value Range</i>	<i>Information</i>
\$12	Trig.	Trigger sign			
0C	LENbyte	Length byte [u08]		2..255	
53	CMDbyte	Command code [u08]			
??	Dbyte 1	Value range [u08]		0..255 = 00h..FFh	Input left
??	Dbyte 2	Value range [u08]		0..255 = 00h..FFh	Input right
??	Dbyte 3	Value range [u08]		0..255 = 00h..FFh	Output left
??	Dbyte 4	Value range [u08]		0..255 = 00h..FFh	Output right
??	Dbyte 5	Function [u08]		0..255 = 00h..FFh	Bit 0 = 1 → Perform ADC offset adjustment Bit 1 = 1 → Not used Bit 2 = 1 → Not used Bit 3 = 1 → Not used Bit 4 = 1 → Left analog input is DC coupled Bit 5 = 1 → Right analog input is DC coupled Bit 6 = 1 → Not used Bit 7 = 1 → Not used
\$0D	Term.	Termination			

Response:

<i>Data</i>	<i>Parameter</i>	<i>Description</i>	<i>Value</i>	<i>Value Range</i>	<i>Information</i>
\$12	Trig.	Trigger sign			
53	CMDbyte	Command code			
\$0D	Term.	Termination			

13.3.2.7. Command 60 Generator or Stream Operation

Decides whether an output signal is put out in a loop (generator) or as a data stream from the USB.

Command:

Data	Parameter	Description	Value	Value Range	Information
\$12	Trig.	Trigger sign			
04	LENbyte	Length byte [u08]		2..255	
60	CMDbyte	Command code [u08]			
??	Dbyte 1	Function [u08]		0..255 = 00h..FFh	Bit 0 = 0/1 → Off / On Bit 1 = 0/1 → Generator / Stream Bit 2 = 0/1 → Normal mode (continuous operation) / start and stop generator synchronous with receiver Bit 3 = 0/1 → Generator cyclic / Single Shot Bit [7:4] = Not used
\$0D	Term.	Termination			

Response:

Data	Parameter	Description	Value	Value Range	Information
\$12	Trig.	Trigger sign			
60	CMDbyte	Command code			
\$0D	Term.	Termination			

13.3.2.8. Command 61 Audio Data Output

Defines audio data of the generated audio signal or the audio stream. In generator mode, the length and the contents of the ring buffer is determined, in streaming mode, the transferred data is appended to the still contained buffer.

To begin with the generator mode, this should be switched off and switched to the generator mode of operation (command 60, data 00). After transferring the data, it can be started (command 60, data 01).

Before starting the streaming operation, you should also switch into the generator mode. After transmission of the first data packet pass over into the streaming mode and turn it on (instruction 60, data 03). If not all supplied values can be written into the buffer during streaming, because it is still partially full, the extra values are discarded and must be sent again. This is necessary so that the USB interface is not blocked by data in the wait loop. The number of the accepted values is returned in the response.

Command:

<i>Data</i>	<i>Parameter</i>	<i>Description</i>	<i>Value</i>	<i>Value Range</i>	<i>Information</i>
\$12	Trig.	Trigger sign			
06	LENbyte	Length byte [u08]		2..255	
61	CMDbyte	Command code [u08]			
??	Dbyte 1	Length [u11]	highByte	0..3 = 00h..03h	Number of following samples - 1
??	Dbyte 2		lowByte	0..255 = 00h..FFh	
\$0D	Term.	Termination			
??	Dbyte 1	First sample left [u24]	highByte	0..255 = 00h..FFh	Audio data (6 bytes per sample)
??	Dbyte 2		middleByte	0..255 = 00h..FFh	
??	Dbyte 3		lowByte	0..255 = 00h..FFh	
??	Dbyte 4	First Sample right [u24]	highByte	0..255 = 00h..FFh	
??	Dbyte 5		middleByte	0..255 = 00h..FFh	
??	Dbyte 6		lowByte	0..255 = 00h..FFh	
...					
??	Dbyte	n - th Sample right [u24]	highByte	0..255 = 00h..FFh	
??	Dbyte		middleByte	0..255 = 00h..FFh	
??	Dbyte		lowByte	0..255 = 00h..FFh	

Response:

<i>Data</i>	<i>Parameter</i>	<i>Description</i>	<i>Value</i>	<i>Value Range</i>	<i>Information</i>
\$12	Trig.	Trigger sign			
61	CMDbyte	Command code			
??	Dbyte 1	Length [u11]	highByte		Number of accepted samples (only relevant for streaming)
??	Dbyte 2		lowByte		
??	Dbyte 3			0..255 = 00h..FFh	Bit 0 = Timeout (receive less data than specified) Bit 1 = Underflow (buffer was run in streaming mode empty)
\$0D	Term.	Termination			

13.3.2.9. Command 74 Read Status

Returns information about the current operating status.

Bit[3:0]	Identified Sample Rate	Bit [3:0]	Identified Sample Rate
0000	Out of range	1000	44.1 kHz
0001	8 kHz	1001	48 kHz
0010	11.025 kHz	1010	64 kHz
0011	12 kHz	1011	88.2 kHz
0100	16 kHz	1100	96 kHz
0101	22.05 kHz	1101	128 kHz
0110	24 kHz	1110	176.4 kHz
0111	32 kHz	1111	192 kHz

Command:

Data	Parameter	Description	Value	Value Range	Information
\$12	Trig.	Trigger sign			
02	LENbyte	Length byte [u08]		2..255	
74	CMDbyte	Command code [u08]			
\$0D	Term.	Termination			

Response:

Data	Parameter	Description	Value	Value Range	Information
\$12	Trig.	Trigger sign			
74	CMDbyte	Command code			
??	Dbyte 1	Flags [u08]		0..255 = 00h..FFh	Bit [3:0] = Valid sample rate on the selected S / PDIF input Bit 4 = Overload of the analog input is detected since last request Bit 5 = Valid signal on the selected S / PDIF input Bit 6 = Error free signal without interruption since last request Bit 7 = Reset since last request
\$0D	Term.	Termination			

13.3.2.10. Command 75 Self - test On / Off

For the self - test, switch the analogue input via relay from the input sockets to the analog output. It can not be turned on when the analog input is selected as the source for the analog output. This would lead to a feedback.

Command:

<i>Data</i>	<i>Parameter</i>	<i>Description</i>	<i>Value</i>	<i>Value Range</i>	<i>Information</i>
\$12	Trig.	Trigger sign			
04	LENbyte	Length byte [u08]		2..255	
75	CMDbyte	Command code [u08]			
??	Dbyte 1	On / Off [u08]			Bit 0 = 0 / 1: Analog input normal / switched to analog output Bit [7:1] = Not used
\$0D	Term.	Termination			

Response:

<i>Data</i>	<i>Parameter</i>	<i>Description</i>	<i>Value</i>	<i>Value Range</i>	<i>Information</i>
\$12	Trig.	Trigger sign			
75	CMDbyte	Command code [u08]			
\$0D	Term.	Termination			

13.3.2.11. Command 80 Write Calibration Values

The values set here come directly to application. In order to store them permanently, execute command 82.

Command:

Data	Parameter	Description	Value	Value Range	Information
\$12	Trig.	Trigger sign			
0E	LENbyte	Length byte [u08]		2..255	
80	CMDbyte	Command code [u08]			
??	Dbyte 1	Target channel [u08]			0 = Input left 1 = Input right 2 = Output left 3 = Output right
??	Dbyte 2	Measurement range [u08]			Measurement range refer to command 53
When input is chosen (Dbyte 1 = 0 or 1):					
??	Dbyte 3	Adjustment precursor [u04]		0..15 = 00h..0Fh	Bit[7] : 0/1 = Level attenuation 1:5 on / off Bit[6] : 0/1 = Level approximation works as an amplifier / attenuator Bit[5:0] : Not used
??	Dbyte 4	Calibration value pos[u12]	highByte	0..4095 = 000h..FFFh	High byte actuating value positive signal path / asymmetric
??	Dbyte 5	Calibration value pos / neg [u12]			Bit[7:4] : Low nibble positive actuating value / asymmetric signal Bit[3:0] : High nibble negative actuating value / asymmetric signal
??	Dbyte 6	Calibration value neg	lowByte	0..4095 = 000h..FFFh	Low byte actuating value negative signal path
When output is chosen (Dbyte 1 = 2 or 3):					
??	Dbyte 3	Setting precursor [u04]		0..15 = 00h..0Fh	Bit[7] : Not used Bit[6] : 0/1 = Level approximation works as an amplifier / attenuator Bit[5:4] : 00 = No attenuation 01 = Attenuation 1:10 10 = Attenuation 1:100 11 = Attenuation 1:1000 Bit[3:0] : High nibble calibration value
??	Dbyte 4	Calibration value [u12]	lowByte	0..4095 = 000h..FFFh	Low byte calibration value
??	Dbyte 5				Not used
??	Dbyte 6				Not used
\$0D	Term.	Termination			

Response:

Data	Parameter	Description	Value	Value Range	Information
\$12	Trig.	Trigger sign			
80	CMDbyte	Command code [u08]			
\$0D	Term.	Termination			

13.3.2.12. Command 81 Read Calibration Values

Returns the currently set (not saved) calibration values. If the stored data should be returned, they need to be loaded first (command 83) if they have been previously modified (command 80).

Command:

Data	Parameter	Description	Value	Value Range	Information
\$12	Trig.	Trigger sign			
06	LENbyte	Length byte [u08]		2..255	
81	CMDbyte	Command code [u08]			
??	Dbyte 1	Target channel [u08]		0..3=00h..03h	0 = Input left 1 = Input right 2 = Output left 3 = Output right
??	0 = Input left				Measuring range table (refer to command 53)
\$0D	Term.	Termination			

Response:

Data	Parameter	Description	Value	Value Range	Information
\$12	Trig.	Trigger sign			
81	CMDbyte	Command code			
When Input:					
??	Dbyte 1	Setting precursor [u04]		0..15 = 00h..0Fh	Bit [7]: 0/1 = 1:5 Level attenuation on / off Bit [6]: 0/1 = Level approximation works as an amplifier / attenuator Bit [5:0]: Not used
??	Dbyte 2	Calibration Value [u12]	highByte	0..4095 = 000h..FFFh	High byte actuating value positive signal path / asymmetric
??	Dbyte 3	Calibration Value [u12]			Bit [7:4]: Low nibble positive actuating value / asymmetric signal Bit [3:0]: High nibble actuating value negative signal path
??	Dbyte 4	Calibration Value	lowByte	0..4095 = 000h..FFFh	Low byte actuating value negative signal path

When Output:					
??	Dbyte 1	Setting precursor [u04] Calibration value pos [u12]		0..15 = 00h..0Fh	Bit [7]: 0 Bit [6]: 0/1 = Level approximation works as an amplifier / attenuator Bit [5:4]: 00 = No attenuation 01 = Signal attenuation 1:10 10 = Signal attenuation 1:100 11 = Signal attenuation 1:1000 Bit [3:0]: High nibble calibration value
??	Dbyte 2	Calibration value pos [u12]	lowByte	0..4095 = 000h..FFFh	Low byte calibration value
00	Dbyte 3				Not used
00	Dbyte 4				Not used
\$0D	Term.	Termination			

13.3.2.13. Command 82 Save Calibration Values

Saves the currently selected calibration values for the analog circuits in the EEPROM.

Command:

Data	Parameter	Description	Value	Value Range	Information
\$12	Trig.	Trigger sign			
02	LENbyte	Length byte [u08]		2..255	
82	CMDbyte	Command code [u08]			
\$0D	Term.	Termination			

Response:

Data	Parameter	Description	Value	Value Range	Information
\$12	Trig.	Trigger sign			
82	CMDbyte	Command code [u08]			
\$0D	Term.	Termination			

13.3.2.14. Command 83 Load Calibration Values

Loads the currently selected calibration values from the EEPROM and brings the device in the startup configuration. The may activated self - test will be switched off again.

Command:

<i>Data</i>	<i>Parameter</i>	<i>Description</i>	<i>Value</i>	<i>Value Range</i>	<i>Information</i>
\$12	Trig.	Trigger sign			
02	LENbyte	Length byte [u08]		2..255	
83	CMDbyte	Command code [u08]			
\$0D	Term.	Termination			

Response:

<i>Data</i>	<i>Parameter</i>	<i>Description</i>	<i>Value</i>	<i>Value Range</i>	<i>Information</i>
\$12	Trig.	Trigger sign			
83	CMDbyte	Command code [u08]			
\$0D	Term.	Termination			

13.3.2.15. Command 84 Save Startup Configuration

Saves the currently set operating state in the EEPROM and restores it after every reset or switch on. This command is intended for stand - alone operation (without PC). In normal project use, the default configuration should not be changed.

Command:

<i>Data</i>	<i>Parameter</i>	<i>Description</i>	<i>Value</i>	<i>Value Range</i>	<i>Information</i>
\$12	Trig.	Trigger sign			
02	LENbyte	Length byte [u08]		2..255	
84	CMDbyte	Command code [u08]			
\$0D	Term.	Termination			

Response:

<i>Data</i>	<i>Parameter</i>	<i>Description</i>	<i>Value</i>	<i>Value Range</i>	<i>Information</i>
\$12	Trig.	Trigger sign			
84	CMDbyte	Command code [u08]			
\$0D	Term.	Termination			

13.3.2.16. Commnd 85 Write EEPROM

Stores 16 bytes of data into an EEPROM page. There are 16 pages of memory are available (= 256 bytes).

Command:

<i>Data</i>	<i>Parameter</i>	<i>Description</i>	<i>Value</i>	<i>Value Range</i>	<i>Information</i>
\$12	Trig.	Trigger sign			
24	LENbyte	Length byte [u08]		2..255	
85	CMDbyte	Command code [u08]			
??	Dbyte 1	Side [u08]		0..15 = 00h..0Fh	
??	Dbyte 2	First data byte [u08]		0..255 = 00h..FFh	
			
??	Dbyte 9	16th data byte [u08]		0..255 = 00h..FFh	
\$0D	Term.	Termination			

Response:

<i>Data</i>	<i>Parameter</i>	<i>Description</i>	<i>Value</i>	<i>Value Range</i>	<i>Information</i>
\$12	Trig.	Trigger sign			
85	CMDbyte	Command code			
\$0D	Term.	Termination			

13.3.2.17. Command 86 Read EEPROM

Returns the entire EEPROM (256 bytes).

Command:

<i>Data</i>	<i>Parameter</i>	<i>Description</i>	<i>Value</i>	<i>Value Range</i>	<i>Information</i>
\$12	Trig.	Trigger sign			
02	LENbyte	Length byte [u08]		2..255	
86	CMDbyte	Command code [u08]			
\$0D	Term.	Termination			

Response:

<i>Data</i>	<i>Parameter</i>	<i>Description</i>	<i>Value</i>	<i>Value Range</i>	<i>Information</i>
\$12	Trig.	Trigger sign			
86	CMDbyte	Command code [u08]			
??	Dbyte 1	First data byte [u08]		0..255 = 00h..FFh	
			
??	Dbyte 256	256th data byte [u08]		0..255 = 00h..FFh	
\$0D	Term.	Termination			