

Product Datasheet - Technical Specifications



More information in our Web-Shop at ► www.meilhaus.com and in our download section.

Your contact

**Technical and commercial sales, price information,
quotations, demo/test equipment, consulting:**

Tel.: **+49 - 81 41 - 52 71-0**

FAX: **+49 - 81 41 - 52 71-129**

E-Mail: sales@meilhaus.com

Downloads:

www.meilhaus.com/en/infos/download.htm

Meilhaus Electronic GmbH | Tel. **+49 - 81 41 - 52 71-0**
Am Sonnenlicht 2 | Fax **+49 - 81 41 - 52 71-129**
82239 Alling/Germany | E-Mail sales@meilhaus.com

Mentioned company and product names may be registered trademarks of the respective companies. Prices in Euro plus VAT. Errors and omissions excepted.
© Meilhaus Electronic.

www.meilhaus.de

ME-Jekyll ME-4610 PCI 16 bit Analog DAQ Board

- 16 single-ended analog inputs. Range ± 10 V.
- High-precision 16 bit/500 kHz A/D conversion. External digital trigger.
- 32 TTL digital I/O channels, grouped in 4x 8 bit ports. Each port programmable as input/output.
- 3x 16 bit counters. All lines wired to the connector.

Model	Analog inputs	Analog outputs	Digital I/O	Counter	Opto isolation	Bus platform
ME-4610 PCI	16 single-ended, ± 10 V, 16 bit/ max. 500 kHz	-	2x 16 (TTL)	3 (16 bit)	-	Standard PCI

Specifications (Ambient temperature 25 °C)

PC Interface

PCI bus	32 bit, 33 MHz, 5 V, PCI Local-Bus-Specification Version 2.1
PCI Express bus	32 bit, 33 MHz, 3.3 V, PCI Express x1 Specification Version 2.0
CompactPCI bus	32 bit, 33 MHz, 5 V, Specification PICMG 2.0 R3.0
Plug&Play	fully supported

Voltage Inputs

Measurand/ Criterion	Condition/ Annotation	Value
Number A/D channels	ME-4610/4650/4660	16 single-ended
	ME-4670/4680	32 single-ended/ 16 differential
„Sample-and-hold“ channels	opt.	8 single-ended simultaneously sampling
A/D converter		500 kHz, 16 bit
Input ranges	ME-4610	-10 V...(+10 V-1 LSB) (1 LSB = 305 µV)
	ME-4650/4660/ 4670/4680	0V...(+2.5 V-1 LSB) (1 LSB=38 µV); 0V...(+10 V-1 LSB) (1 LSB=152 µV); -2.5 V...(+2.5 V-1 LSB) (1 LSB=76 µV); -10 V...(+10 V-1 LSB) (1 LSB=305 µV)
Full-scale-error	unipolar	0 V+ 10 LSB, +FS-10 LSB
	bipolar	-FS+ 10 LSB, +FS-10 LSB
Inputs protected up to		± 15 V
Input impedance	without sample-and- hold	R_{IN} = typ. 600 MΩ; C_{IN} = typ. 3 pF

Measurand/ Criterion	Condition/ Annotation	Value
	channels with sample-and-hold option:	$R_{IN} = \text{typ. } 1 \text{ M}\Omega$; $C_{IN} = \text{typ. } 5 \text{ pF}$
Total accuracy	full-scale in input range $\pm 10 \text{ V}$	typ. $\pm 4 \text{ LSB}$, max. $\pm 10 \text{ LSB}$
A/D FIFO		2048 values FIFO
Channel list		max. 1024 entries (channel number, gain, uni-/bipolar, single-ended/differential)
Smallest time unit for CHAN and SCAN timer		$1 \text{ Tick} \triangleq 30.30 \text{ ns} \triangleq 33 \text{ MHz}$
CHAN time (time between two consecutive channel list entries)	PCI, cPCI:	$2 \mu\text{s}$ bis $\sim 130 \text{ s}$ (in steps of 30.30 ns)
	PCIe	$4 \mu\text{s}$ bis $\sim 130 \text{ s}$ (in steps of 30.30 ns)
SCAN time (time between two consecutive channel list processings)	PCI, cPCI	$4 \mu\text{s}$ to $\sim 30 \text{ minutes}$ (in steps of 30.30 ns)
	PCIe (at least 2 channels)	$8 \mu\text{s}$ to $\sim 30 \text{ minutes}$ (in steps of 30.30 ns)
Total sampling rate*	single operation (dependent of system)	max. 500 kHz (cPCI, PCI) max. 250 kHz (PCIe)
	Streaming operation	max. 500 kHz (cPCI, PCI) max. 250 kHz (PCIe)
	sample-and-hold	number of channel list entries (min. 2) x CHAN time + $1.5 \mu\text{s}$ (relaxation time)
Relaxation time	sample-and-hold	$1.5 \mu\text{s}$
Operation modes		„single“, „streaming“, optional: „sample-and-hold“
Trigger modes	all models	software start, external digital trigger
	only ME-4670/4680	external analog-trigger
Ext. Trigger edges		rising, falling, any
Opto-isolation	„i“-versions	to 500 V

Measurand/ Criterion	Condition/ Annotation	Value
Reference to ground	„i“-versions – A/D and D/A section with common ground, isolated from PC ground and the rest of the board	A_GND

*System-related, boards installed into a ME-Synapse do not achieve the full sample rate. The actual achievable sample rate heavily depends on the performance of your computer and the number of USB-devices connected.

External Trigger without Opto-isolation

Measurand/ Criterion	Condition/ Annotation	Value
Reference to ground		PC ground (PC_GND)
Input Level U_{IL}	$V_{CC} = 4.5\text{ V}$	max. 0.9 V
U_{IH}	$V_{CC} = 4.5\text{ V}$	min. 3.15 V
Delay time		max. 30 ns

External Trigger with Opto-isolation

Measurand/ Criterion	Condition/ Annotation	Value
Reference to ground		Digital-I/O ground (DIO_GND)
Input current I_F		$7.5\text{ mA} \leq I_F \leq 10\text{ mA}$
Voltage level		typ. 5 V
Delay time		typ. 80 ns

Voltage Outputs (ME-4660, ME-4670, ME-4680)

Measurand/ Criterion	Condition/ Annotation	Value
Number of D/A channels	ME-4660	2
	ME-4670/4680	4
D/A converter		1 serial converter per channel
Resolution		16 bit

Output range		$\pm 10\text{ V}$
Output-current	per channel	max. 5 mA
Settling time (DAC)	full-scale (-10 V \rightarrow +10 V)	max. 2 μs
Total accuracy		max. $\pm 10\text{ mV}$
Operation modes		„single“, „streaming“
Trigger modes		software start, ext. digital trigger synchronous start (software/external)
External trigger edges		rising, falling any
Opto-isolation	„i“-versions	max. 500 V
Reference to ground	„i“-versions – A/D and D/A section with common ground, isolated from PC ground and the rest of the board	A_GND

Timer controlled Output (only ME-4680)

Measurand/ Criterion	Condition/ Annotation	Value
Channel no. (subdevice)	independent of one another	0...3
D/A FIFOs	per channel	4096 values
Sample rate		max. 500 kS/s
D/A timer	programmable in steps of 30.30 ns	2 μs ... 130 s

External Trigger without Opto-isolation

Measurand/ Criterion	Condition/ Annotation	Value
Reference to ground		PC ground (PC_GND)
Input level U_{IL}	$V_{CC} = 4.5\text{ V}$	max. 0.9 V
U_{IH}	$V_{CC} = 4.5\text{ V}$	min. 3.15 V
Delay-time		max. 30 ns

External Trigger with Opto-isolation

Measurand/ Criterion	Condition/ Annotation	Value
Reference to ground		digital-I/O ground (DIO_GND)
Input current I_F		$7.5 \text{ mA} \leq I_F \leq 10 \text{ mA}$
Voltage level		typ. 5 V
Delay time		typ. 80 ns

Digital I/Os

Number of ports	4 x 8 bit
------------------------	-----------

...without Opto-Isolation

Measurand/ Criterion	Condition/ Annotation	Value
Reference to ground		PC ground (PC_GND)
Port-type		bi-directional TTL ports
Output level U_{OL}	at 24 mA	max 0.5 V
U_{OH}	at -24 mA	min. 2.4 V
Input level U_{IL}	at $V_{CC} = 5 \text{ V}$	max. 0.8 V
U_{IH}	at $V_{CC} = 5 \text{ V}$	min. 2 V
Input current		$\pm 1 \mu\text{A}$
Sample rate		max. 500 kS/s (2 μs)

...with Opto-Isolation („i“-versions):

Measurand/ Criterion	Condition/ Annotation	Value
Reference to ground	„i“-versions – digital-I/O ground, isolated from PC ground and the rest of the board	DIO_GND
Port type	Port A	output port
	Port B	input port
	Port C, D	bi-directional TTL ports (refer to the levels „without opto-isolation“)

Output level U_{max}	Port A, B	42 V (depends on external supply)
I_{OUT}	Port A, B	max. 30 mA
Input level I_F	Port A, B	$7.5 \text{ mA} \leq I_F \leq 10 \text{ mA}$
U_{IL}	Port A, B	max. 0,8 V
U_{IH}	Port A, B	min. 4.5 V, max. 5 V
Sample rate		max. 172 kS/s (5.8 μ s)

*optional higher input voltages possible – please contact our support division.

Bit-Pattern Output

Measurand/ Criterion	Condition/ Annotation	Value
Ports	flexible port mapping to all digital output ports	A, B, C, D
Operation modes		„Streaming“
Bit-pattern FIFO	(shares with D/A FIFO 3)	4 k values
Sample rate	TTL port	max. 500 kS/s (2 μ s)
	opto-isolated port	max. 172 kS/s (5.8 μ s)
Bit-pattern timer	programmable in steps of 30.30 ns	2 μ s...130 s
External trigger input	Type: digital	AO_TRIG_3
Input level		see external trigger D/A section
Delay time	without opto-isolation	max. 30 ns
	with opto-isolation	typ. 80 ns
Trigger modes		software start, ext. digital trigger
External trigger edges		rising, falling, any

Frequency Input/Output

Availability	„f“-option for ME-4660/4670/4680
Signal curve	rectangular

Frequency Measurement Channels

Measurand/ Criterion	Condition/ Annotation	Value
Reference to ground		PC ground (PC_GND)
Number of channels	(FI_0...3)	4 inputs (TTL)
Input level	U_{IL} bei $V_{CC} = 5\text{ V}$	max. 0.8 V
	U_{IH} bei $V_{CC} = 5\text{ V}$	min. 2 V
Input current		$\pm 1\ \mu\text{A}$
Period (T)	$T_{min.} = T_{min. asym.} = T_{min sym.}$ $T_{max. asym.}$ $T_{max. sym.}$	181.81 ns (5.5 MHz) 32.5 s (0.03 Hz) 65 s (0.015 Hz)
Duty-cycle	variable independency of T	adjustable in steps of 1 Tick
Resolution	1 Tick	30,30 ns
Accuracy		$\pm 30,30\text{ ns}$
Operation modes		„Single“

Pulse Generator Channels

Measurand/ Criterion	Condition/ Annotation	Value
Reference to ground		PC ground (PC_GND)
Number of channels	(FO_0...3)	4 outputs (TTL)
Output level	U_{OL} at $I_{OUT} = 24\text{ mA}$	max. 0,5 V
	U_{OH} at $I_{OUT} = 24\text{ mA}$	min. 2.4 V
Period (T)	$T_{min.} = T_{min. asym.} = T_{min sym.}$ $T_{max. asym.}$ $T_{max. sym.}$	181.81 ns (5.5 MHz) 32.5 s (0.03 Hz) 65 s (0.015 Hz)
Duty-cycle	variable in dependency of T	adjustable in steps 1 Tick
Resolution	1 Tick	30,30 ns
Accuracy		$\pm 30,30\text{ ns}$
Operation modes		„Single“

Counter

Number	3x16 bit (1x82C54)
Clock source	ext. up to max. 10 MHz

...without opto-isolation

Measurand/ Criterion	Condition/ Annotation	Value
Reference to ground		PC ground (PC_GND)
Level for counter output (OUT x)		
U_{OL}	$I_{OL} = +7.8 \text{ mA}$	max. +0.45 V
U_{OH}	$I_{OH} = -6 \text{ mA}$	min. +2.4 V
Level for counter inputs (CLK x, GATE x)		
U_{IL}	$I_{ILmax} = \pm 10 \mu\text{A}$	-0.5 V...+0.8 V
U_{IH}	$I_{IHmax} = \pm 10 \mu\text{A}$	+2.2 V...+6 V

...with opto-isolation („i“-versions)

Measurand/ Criterion	Condition/ Annotation	Value
Reference to ground	„i“-versions – counter ground, isolated from PC ground and the rest of the board	CNT_GND
External supply for opto-couplers	CNT_VCC_IN	+5 V/30 mA
Level for counter outputs (OUT x)		
U_{max}		42 V
I_{OUT}		max. 30 mA
Level for counter inputs (CLK x, GATE x)		
I_F		$7.5 \text{ mA} \leq I_F \leq 10 \text{ mA}$
U_{IL}		max. 0.8 V
U_{IH}		min. 4.5 V, max. 5 V*

*optional higher input voltages possible – please contact our support division.

Optional: Supplying opto-couplers with VCC from analog section (A_VCC). Note: the electrical isolation between analog and counter section will be removed (CNT_GND = A_GND), see Diagram 23.

External Interrupt

Measurand/ Criterion	Condition/ Annotation	Value
Ext. interrupt input	directly sent to the system	EXT_IRQ
Input level		see digital I/Os
Reference to ground	„TTL“	PC ground(PC_GND)
	„Opto“	digital-I/O ground (DIO_GND)

General Information

Measurand/ Criterion	Condition/ Annotation	Value
Supply A/D section	2 DC/DC converter	± 5 V und ± 15 V (2 x 3 W)
Power consumption	without external load	typ. 2.8 A
Load for VCC_OUT		max. 200 mA
Physical size (without mounting bracket and con- nector)	ME-4610 PCI	136 mm x 107 mm
	ME-4650/4660/4670/ 4680 PCI	175 mm x 107 mm
	PCI Express versions	167.65 mm x 111.15 mm
	CompactPCI versions	3 HE CompactPCI board
Connectors	ST1	78-pin D-Sub female connector
	ST2	20-pin IDC-connector
Operating temperature		0...70 °C
Storage temperature		-40...100 °C
Relative humidity		20...55 % (non-condensing)

Certification	CE
---------------	----

Pinout

Pin-name	Function
AI X	analog input channels
AI_TRIG_D	digital trigger input for A/D section
AI_TRIG_A+	analog trigger input for A/D section (positive comparator)
AI_TRIG_A-	analog trigger input for A/D section (negative comparator input)
AO X	analog output channels
AO_TRIG x	digital trigger input separately for each D/A channel
DIO_Ax	digital-I/O port A
DIO_Bx	digital-I/O port B
DIO_Cx	digital-I/O port C
DIO Dx	digital-I/O port D
EXT_IRQ	external interrupt input
CLK_x	clock input for counter
GATE_x	gate input for counter
OUT_x	counter output
PC_GND	ST1 not opto-isolated models: Common ground of all functional groups (=PC ground; ST2: PC ground)
VCC_OUT	ST1 not opto-isolated models: VCC-output (+5 V from PC); ST2: +5 V from PC; total load max. 200 mA
n.c.	Pin not connected
Valid for opto-isolated models	
A_GND	Ground for A/D and D/A section
DIO_GND	Ground for digital-I/O section
CNT_GND	Ground for counter section
CNT_VCC_IN	Default: Input for external power supply (+5 V ± 10 %) for the opto-couplers of the counters.
A_VCC	Optional (see diagram 23 on page 25): Sourcing the opto-couplers of the counters by the analog section (A_VCC) No external wiring to pin 1!

78-pin D-Sub Connector (ST1) ME-4610

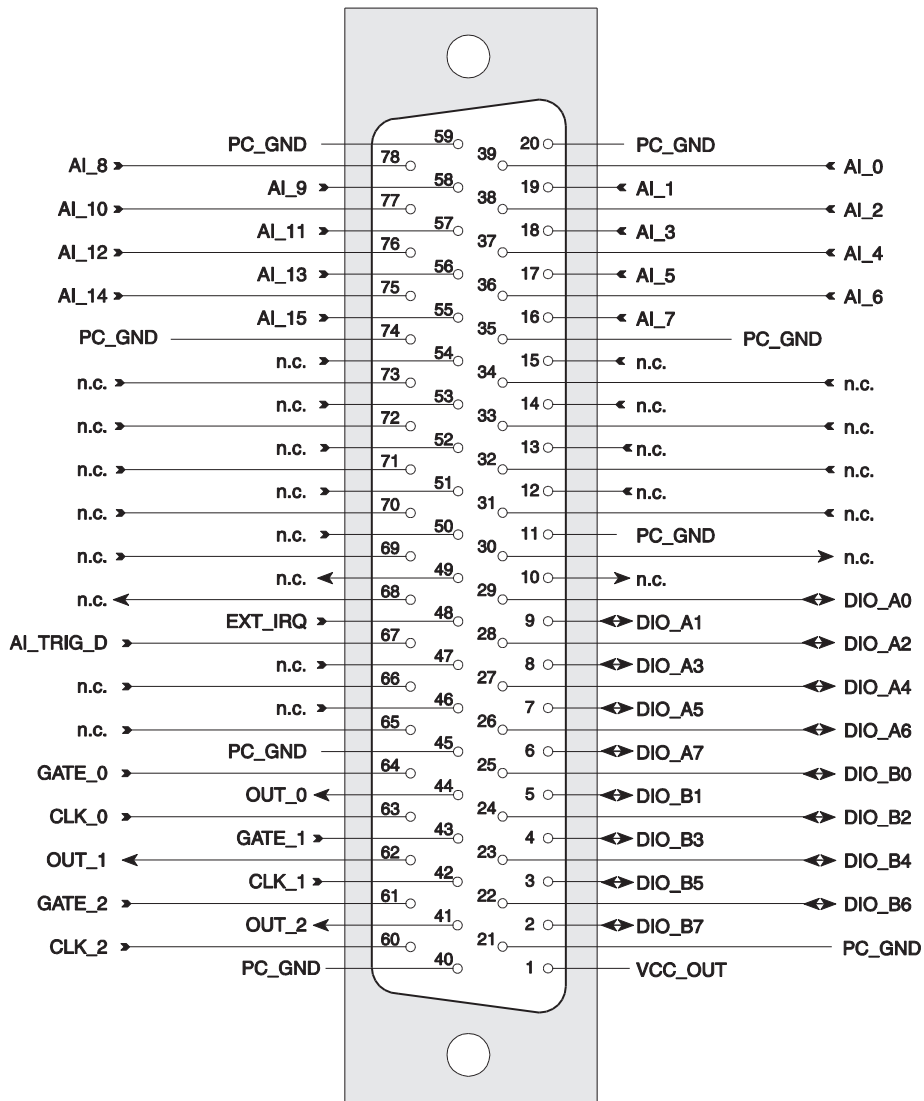

Diagram 29: 78-pin D-Sub female connector ME-4610 (ST1)

78-pin D-Sub Connector (ST1) ME-4650/4660/4670/4680

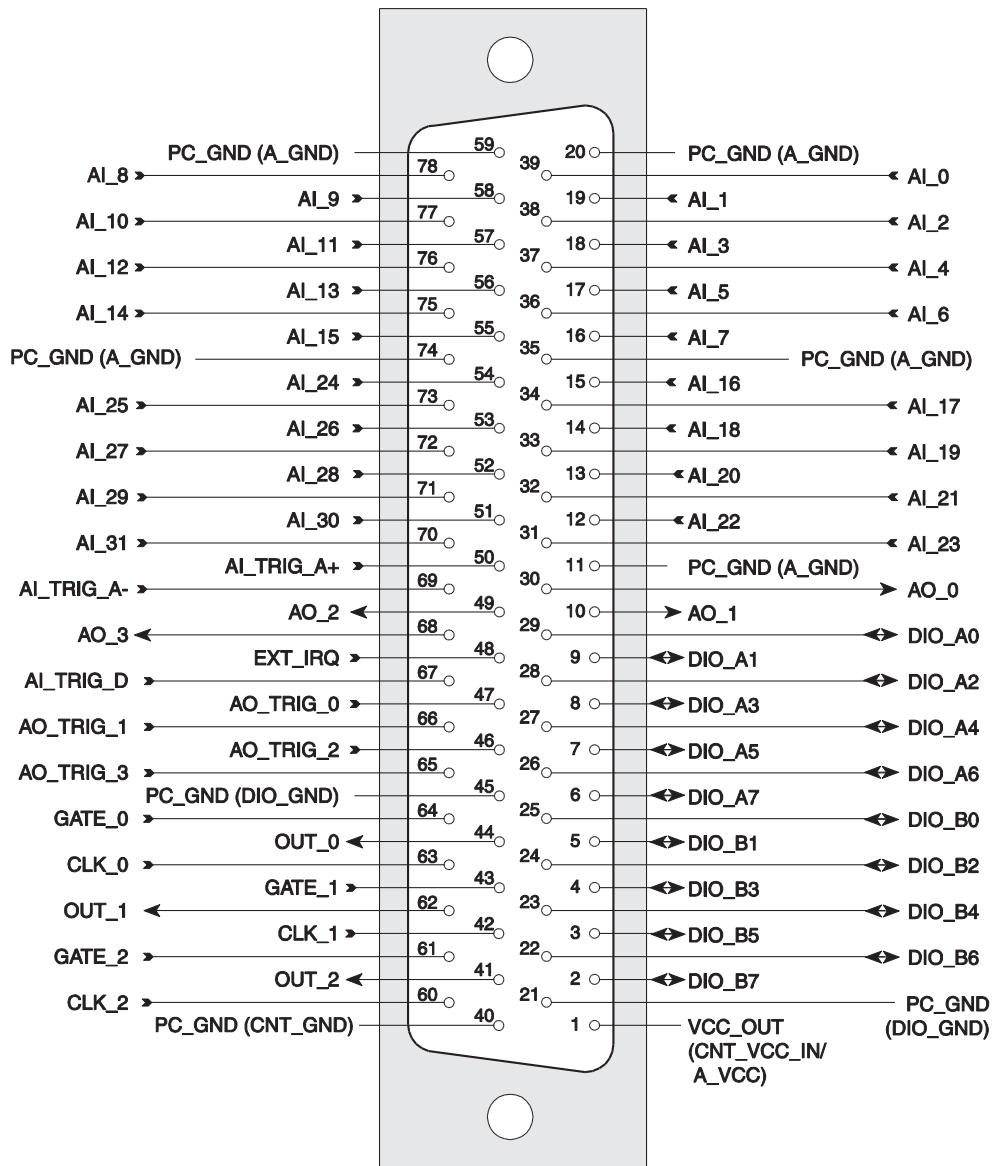

Diagram 30: 78-pin D-Sub female connector
ME-4650/4660/4670/4680 (ST1)

Depending on the model not all pins of the 78-pin D-Sub connector are connected. The labels in brackets concern the opto-isolated versions ("I"-versions).

Auxiliary Connector „DIO“ (ST2)

Adapter cable (ME-AK-D 25F/S (cPCI)) from 20-pin IDC-connector to mounting bracket with 25-pin D-Sub female connector (comes with the board).

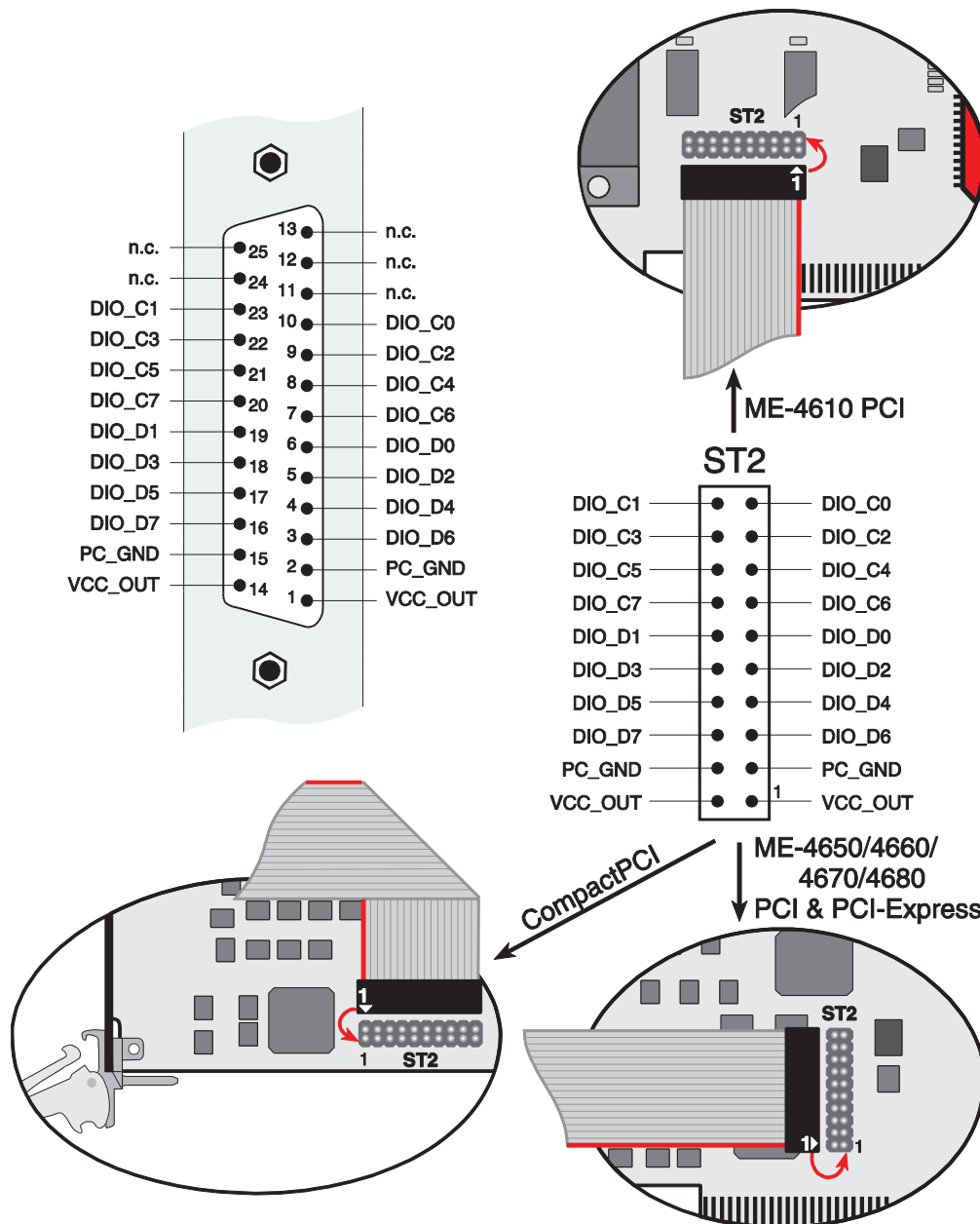

Diagram 31: Auxiliary connector "DIO" for ME-4600 (top view)

Note: Connect the mounting bracket pin 1 of the flat ribbon cable (red marked line) as shown above to the IDC-connector ST2.

Auxiliary Connector „FIO“ (ST2)

Diagram 32 shows the pinout of ST 2 in combination with „FIO“-option. Four pulse generator outputs and four frequency measurement inputs are available instead of the digital-I/O ports C and D.

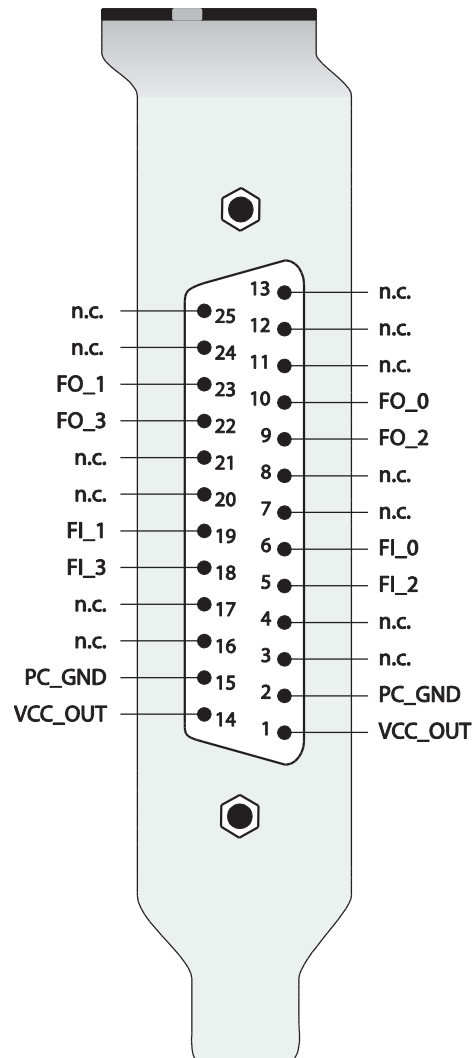

Diagram 32: Auxiliary connector "FIO" for ME-4600 (top view)

Additional legend:

FI_x Frequency measurement input („FIO“-Option)

FO_x Pulse generator output („FIO“-Option)

Attention! Pins labeled with „n.c.“ may not be connected by your external switching. Otherwise the board can be irreversibly damaged!

Note: See Diagram 31 for connecting the adapter cable ME-AK-D25F/S (cPCI).