

Meilhaus Electronic Manual

ME-5200 3.0E

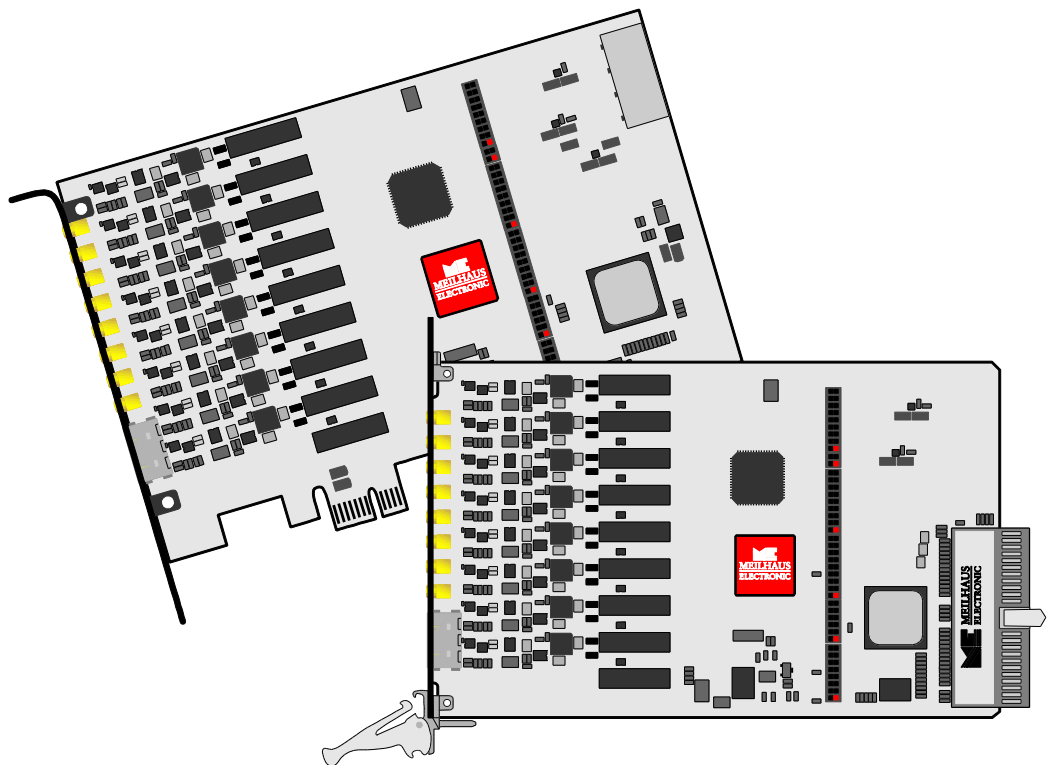

High-Speed Analog DAQ Board

with Individually Isolated A/D Channels, 8 Digital I/Os with
Bit-Pattern Detection
(alternatively: Frequency Measurement or Pulse Generator)

Imprint

Manual ME-5200 Series

Revision 3.0E

Revised: 2019-11-27

Meilhaus Electronic GmbH
Am Sonnenlicht 2
D-82239 Alling bei München
Germany

www.meilhaus.de

© Copyright 2019 Meilhaus Electronic GmbH

All rights reserved. No part of this publication may be reproduced or distributed in any form whether photocopied, printed, put on microfilm or be stored in any electronic media without the expressed written consent of Meilhaus Electronic GmbH.

Important note:

The information contained in this manual has been reviewed with great care and is believed to be complete and accurate. Meilhaus Electronic assumes no responsibility for its use, any infringements of patents or other rights of third parties which may result from use of this manual or the product. Meilhaus Electronic assumes no responsibility for any problems or damage which may result from errors or omissions. Specifications and instructions are subject to change without notice.

Note the Meilhaus Electronic general terms of business:

www.meilhaus.de/en/infos/my-shop/tob/

All trademarks acknowledged. All trademarks are property of their respective owners.

Content

| | | |
|----------|--|-----------|
| 1 | Introduction..... | 5 |
| 1.1 | Important Notes | 5 |
| 1.1.1 | Use in Accordance with the Requirements | 5 |
| 1.1.2 | Improper Application | 6 |
| 1.1.3 | Unforeseeable Misapplications | 6 |
| 1.2 | Package Contents | 6 |
| 1.3 | Features | 7 |
| 1.4 | System Requirements | 10 |
| 1.5 | Software Support | 10 |
| 2 | Starting up..... | 11 |
| 2.1 | Software Installation | 11 |
| 2.2 | Test Program..... | 11 |
| 2.3 | Installation of the ME-5200 PCI Express Board..... | 11 |
| 2.4 | Power Supply for PCI-Express Models..... | 12 |
| 3 | Hardware | 13 |
| 3.1 | Block diagram | 13 |
| 3.2 | ME-5200 cPCI | 14 |
| 3.3 | ME-5200 PCIe | 14 |
| 3.4 | A/D Section | 15 |
| 3.4.1 | Differential Inputs..... | 15 |
| 3.4.1.1 | Input Voltage Ranges | 16 |
| 3.4.1.2 | Optional Input Circuitry | 16 |
| 3.4.2 | External Trigger A/D Section..... | 18 |
| 3.4.2.1 | Edge Detection..... | 18 |
| 3.4.2.2 | Digital Trigger Inputs..... | 19 |
| 3.5 | Digital-I/O Section | 20 |
| 3.5.1 | Digital Inputs | 20 |
| 3.5.2 | Digital Outputs..... | 20 |
| 3.6 | Frequency Input/Output | 21 |
| 3.7 | External Interrupt | 22 |
| 4 | Programming | 23 |

| | | |
|---------|---|----|
| 4.1 | Single Operation Mode | 25 |
| 4.1.1 | Analog Input | 25 |
| 4.1.2 | Digital Input/Output | 25 |
| 4.1.3 | Frequency Input/Output | 26 |
| 4.1.3.1 | Frequency Measurement | 28 |
| 4.1.3.2 | Pulse Generator | 28 |
| 4.2 | Streaming Mode Operation | 28 |
| 4.2.1 | Analog Input | 28 |
| 4.2.1.1 | Stream Timer | 29 |
| 4.2.1.2 | Stream Trigger Sample | 29 |
| 4.2.1.3 | External Trigger | 29 |
| 4.3 | Interrupt Operation | 30 |
| 4.3.1 | Bit-Pattern Change | 31 |
| 4.3.2 | Bit-Pattern Compare | 32 |
| 5 | Appendix | 33 |
| A | Specification | 33 |
| B | Pinout | 39 |
| B1 | HDMI Connector (Digital I/O) | 40 |
| B2 | Mounting Bracket with Analog Inputs | 41 |
| B3 | Terminal Block for the ME-5200 | 42 |
| C | Accessories | 43 |
| D | Technical Questions | 44 |
| D1 | Hotline | 44 |
| E | Index | 45 |

1 Introduction

Valued customer,

Thank you for purchasing this device from Meilhaus Electronic. You have chosen an innovative high-technology product that left our premises in a fully functional and new condition.

Please take the time to carefully examine the contents of the package for any loss or damage that may have occurred during shipping. If there are any items missing or if an item is damaged, please contact us immediately.

Before installing the board in your computer, we recommend you read this manual carefully, especially the chapter describing board installation.

The descriptions in this manual concern PCI-Express- and CompactPCI-versions of the ME-5200-series if not otherwise noted.

1.1 Important Notes

1.1.1 Use in Accordance with the Requirements

The PC boards of the ME-5200 series are designed for fast acquisition and output of analog and digital signals using a PC. Depending on the type install the models of the ME-5200 series into:

- a free PCI-Express slot (PCIe) or
- a free CompactPCI slot (cPCI)

For information on how to install a plug-in board, please read the manual of your PC. Please follow the notes and the specifications from page 33 onward.

- Please ensure sufficient heat dissipation for the board within the PC housing.
- When using the configuration “pulse generator” (FO) unused output pins should not be connected.
- The isolated analog inputs provide electrical isolation of the device of up to 300 V with respect to the PC ground. Dust or other contamination can impair the isolation.
- Make sure that the isolation is intact for voltages >42 V.

- Note that the computer must be powered up, prior to connecting signals by the external wiring of the board.
- As a basic principle, all connections to the board should only be made or removed in a powered-down state of all components.
- Ensure that no static discharge occurs while handling the board or while connecting/disconnecting the external cable.
- Ensure that the connection cable is properly connected.

1.1.2 Improper Application

PC plug-in boards for the PCI-Express- or CompactPCI-bus may not be taken into operation outside of the PC. Never connect the devices with voltage-carrying parts, especially not with mains voltage. As power supply for the USB models only an authorized power adaptor may be used.

Make sure that no contact with voltage-carrying parts can happen by the external wiring of the device. As a basic principle, all connections should only be made or removed in a powered-down state.

1.1.3 Unforeseeable Misapplications

The device is not suitable to be used as a children's toy, in the household or under unfavourable environmental conditions (e.g. in the open). Appropriate precautions to avoid any unforeseeable misapplication must be taken by the user.

1.2 Package Contents

We do our best to ensure your delivery is complete. Nonetheless, please check the list enclosed to verify the contents of your delivery. You should find included:

- Analog DAQ-board of the ME-5200 series with individual, isolated A/D-channels for the PCI-Express- or CompactPCI-bus.
- Manual in PDF format on CD/DVD.
- Driver software on CD/DVD.

1.3 Features

The boards of the ME-5200 series are fast, analog DAQ-boards with individual, isolated A/D-channels for the PCI-Express- and CompactPCI-systems.

Model Overview

| Model | Channels | Resolution | Rate | DIO | FI/FO** |
|------------------|----------|------------|----------|-----------|---------------|
| ME-5284-8 | 8 diff. | 18 bit | 1.6 MS/s | 1 x 8 bit | 4 x FI/4 x FO |
| ME-5284-4 | 4 diff. | | 1.6 MS/s | 1 x 8 bit | 4 x FI/4 x FO |
| ME-5284-8 | 8 diff. | | 1.0 MS/s | 1 x 8 bit | 4 x FI/4 x FO |
| ME-5283-4 | 4 diff. | | 1.0 MS/s | 1 x 8 bit | 4 x FI/4 x FO |
| ME-5282-8 | 8 diff | | 500 kS/s | 1 x 8 bit | 4 x FI/4 x FO |
| ME-5282-4 | 4 diff | | 500 kS/s | 1 x 8 bit | 4 x FI/4 x FO |
| ME-5281-8 | 8 diff | | 250 kS/s | 1 x 8 bit | 4 x FI/4 x FO |
| ME-5281-4 | 4 diff | | 250 kS/s | 1 x 8 bit | 4 x FI/4 x FO |
| ME-5265-8 | 8 diff | 16 bit | 2.0 MS/s | 1 x 8 bit | 4 x FI/4 x FO |
| ME-5265-4 | 4 diff | | 2.0 MS/s | 1 x 8 bit | 4 x FI/4 x FO |
| ME-5263-8 | 8 diff | | 1.0 MS/s | 1 x 8 bit | 4 x FI/4 x FO |
| ME-5263-4 | 4 diff | | 1.0 MS/s | 1 x 8 bit | 4 x FI/4 x FO |
| ME-5262-8 | 8 diff | | 500 kS/s | 1 x 8 bit | 4 x FI/4 x FO |
| ME-5262-4 | 4 diff | | 500 kS/s | 1 x 8 bit | 4 x FI/4 x FO |
| ME-5261-8 | 8 diff | | 250 kS/s | 1 x 8 bit | 4 x FI/4 x FO |
| ME-5261-4 | 4 diff | | 250 kS/s | 1 x 8 bit | 4 x FI/4 x FO |

Table 1: ME-5200 series model overview

*Please note that not every theoretically possible variant is available as standard (see: www.meilhaus.com). You can select optional input circuitry, depending on your application – see table 3 on page 17.

**Alternative configurations can be activated via ME-iDC.

- **Analog input channels:** Depending on the model, the ME-5200 comprises 4 or 8 fast, electrically isolated analog input channels (subdevice 0). Each channel is independently floating, so that genuine differential measurements can be taken without reference to ground. The advantage of differential measurement lies in the high degree to which common mode interference is suppressed.

- Depending on which **A/D converter** is fitted, the maximum sample rate lies between 250 kS/s and 1.6 MS/s for the 18-bit version, and between 250 kS/s and 2 MS/s for the 16-bit version. All of the analog channels are sampled synchronously.
- **Electrical isolation:** The analog input channels, as well as both the digital trigger inputs, are isolated from one another and from the PC ground, for up to 300 V.
- **Optional input circuitry for analog inputs:** When you order your board you can choose between the following input circuits, for which there is an additional charge, to suit your application. See also chapter 3.4.1.2 on page 16.
 - **Option “E”:** Extended input voltage range of up to ± 104 V. E.g. for applications in the electrical mobility field.
 - **Option “F”:** For signal analysis with a particularly high signal-to-noise ratio (only for the ME-5284-x).
 - **Option “T”:** Impedance matched to standard oscilloscope probes.

If needed, the board, or some of its channels, can also be retrofitted by our service department. For this purpose, please contact our Support Department at: (support@meilhaus.com).

- **Digital inputs/outputs:** The ME-5200 incorporates an 8-bit digital-I/O port (subdevice 1). The direction of each port can be defined in software. Immediately after powering up, the port is configured as an input. A port that is configured as an output can also be read back!
- **Frequency counter:** Alternatively, the concept of the “configurable subdevices” allows subdevice 1 to be employed as a frequency counter. Four independent channels are available for measuring the frequency and duty cycle of rectangular signals (max. 5.5 MHz).
- **Pulse generator:** Alternatively, the concept of the “configurable subdevices” allows subdevice 1 to be employed as a rectangular wave generator. Four independent channels are available for the output of a periodic, rectangular signal at up to 5.5 MHz with a variable duty cycle.
- **Bit-pattern detection:** The bit-pattern at the digital input port can be monitored if required. Depending on the mode, an interrupt can be triggered in response to a change in the bit-pattern, or to equality or inequality of the pattern.

Thanks to the DMA-architecture, the data can be transferred from the board to the PC at very high speed. In the streaming operation

mode, a sampling rate of up to 2 MS/s per channel is possible (see also table 4). The actual transmission rate will depend on the operation mode and the configuration of your computer.

Depending on requirements, you can select from the following operation modes:

- **Single:** In this operation mode, reading an analog input can be initiated by software or by external digital trigger (see chapter 4.1.2 on page 25).
- **Streaming:** In this operation mode, the analog values acquired are read in from subdevice 0 via a FIFO. It is possible to choose between a timer and/or external trigger signals for timing control. A large number of trigger options, with which you can define start and stop conditions, are available (see chapter 4.2.1 on page 28).
- **Interrupt:** For interrupt handling in the “bit-pattern change” and “bit-pattern compare” modes (see chapter 4.3 on page 30).

| Model | ME-5200 |
|---|---|
| PC interface | cPCI/PCle |
| Board type | basic board |
| AI channels | 8 diff. |
| AI sampling-rate | max. 2.0 MS/s* |
| AI resolution | 16/18 bit* |
| AI input-ranges | ± 10.4 V (standard) ± 104 V (optional) |
| Channel list | 8 entries |
| Isolation AI channels | ✓ per channel |
| External trigger for AI streaming | ✓ |
| Software Start/Stop for streaming mode | ✓ |
| DIO channels | 1 x 8-bit DIO |
| Bit pattern change | ✓ |
| Bit pattern compare | ✓ |
| Frequency measurement | 4 channels |
| Pulse generator | 4 channels |
| FI/FO frequency | 5.5 MHz/ 5.5 MHz |
| DI/FI level | 5 V (TTL) |

| | |
|--------------------------------|-----------------------------|
| DO/FO level | 5 V (TTL) |
| Active termination | - |
| DIO-isolation | - |
| Sink/source change-over | - |
| Temperature monitoring | - |
| External wiring | 8 x MMCX coax + HDMI socket |
| Alternative firmware | ✓ |
| Subdevice configurable | ✓ |

Table 2: Overview of the plug-on boards for the ME-5200

*Depending on the model or option **optional via ME- AK- D25F/S (cPCI) ***only for subdevice 0..3 (4 x 8 bit)

1.4 System Requirements

The ME-5000 series may be installed into any PC with x-86 processor architecture and a free standard PCI-Express- resp. CompactPCI-slot (32 bit, 33 MHz, 5 V). The board is supported by the Meilhaus Electronic Intelligent Driver System (ME-iDS).

1.5 Software Support

The ME-series is supported by the Meilhaus Electronic Intelligent Driver System (ME-iDS). The ME-iDS is a unique driver system covering different devices and operating systems. It supports Windows 2000/XP/Vista and Windows 7, 8.1, 10 and contains a universal function library (API) for all common programming languages.

A detailed description of the functions can be found in the ME-iDS manual on the CD/DVD enclosed.

Please also note the corresponding README-files.

2 Starting up

Please read your computer's instruction manual on how to install new hardware components **before installing the board**.

2.1 Software Installation

- Installation under Windows

The following basic procedure should be used:

If you have received the driver software as an archive file please unpack the software **before installing the board**. First choose a directory on your computer (e.g. `C:\Temp\Meilhaus\ME-iDS`).

Use the Meilhaus Electronic Intelligent Driver System (ME-iDS) for programming your new data acquisition hardware. For installation and operation of the driver system, please follow the documentation in electronic form included with the software package.

2.2 Test Program

For simple testing of the board use the corresponding test program provided with the ME-iDS.

2.3 Installation of the ME-5200 PCI Express board

Fix the ME-5200 PCIe and ensure that the distance between the metal edge of the housing and the MMCX- resp. HDMI-connector is maximum. It should be at least 1 mm, otherwise the isolation of the channels and the specified isolation voltage cannot be guaranteed!

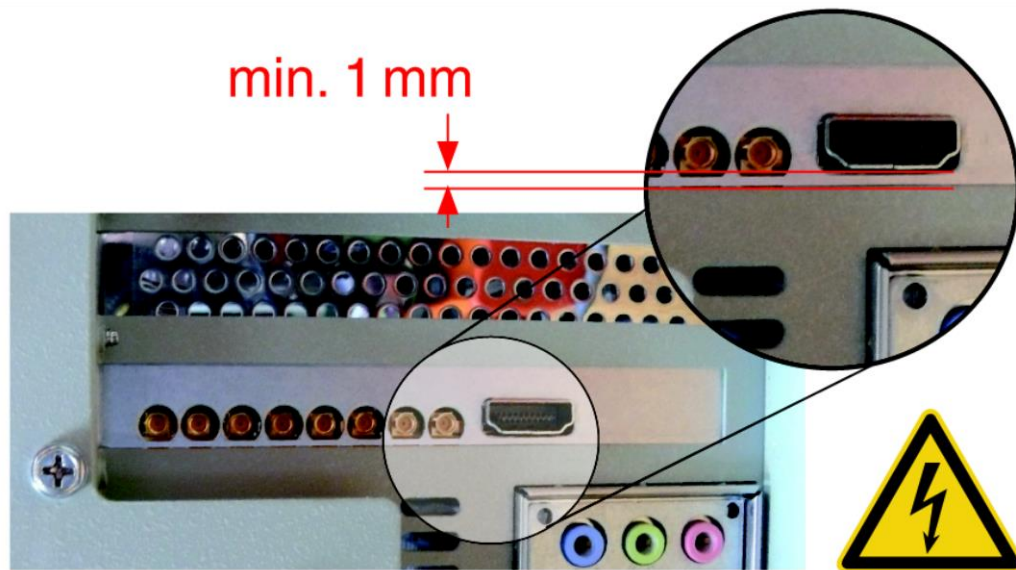

Diagram 1: Installing the ME-5200 PCI-Express

2.4 Power Supply for I-Express Models

Because of the PCI-Express slot drive's insufficient current for operating the board, an additional supply is required via the PC power supply. For that purpose connect a free "MOLEX" connector of the PC (as used for power supply of drives) with the appropriate terminal of the board (see the following diagram).



Otherwise the board may be irreversibly damaged!

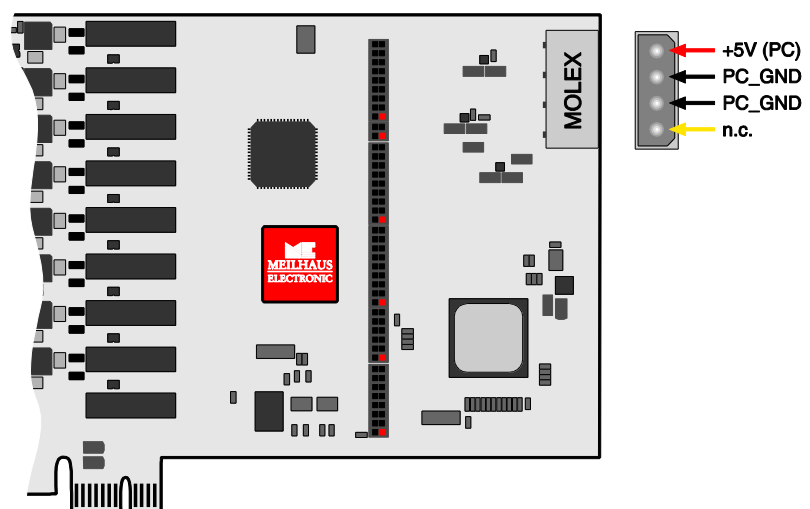

Diagram 2: Additional power to the PCI-Express models

3 Hardware

3.1 Block diagram

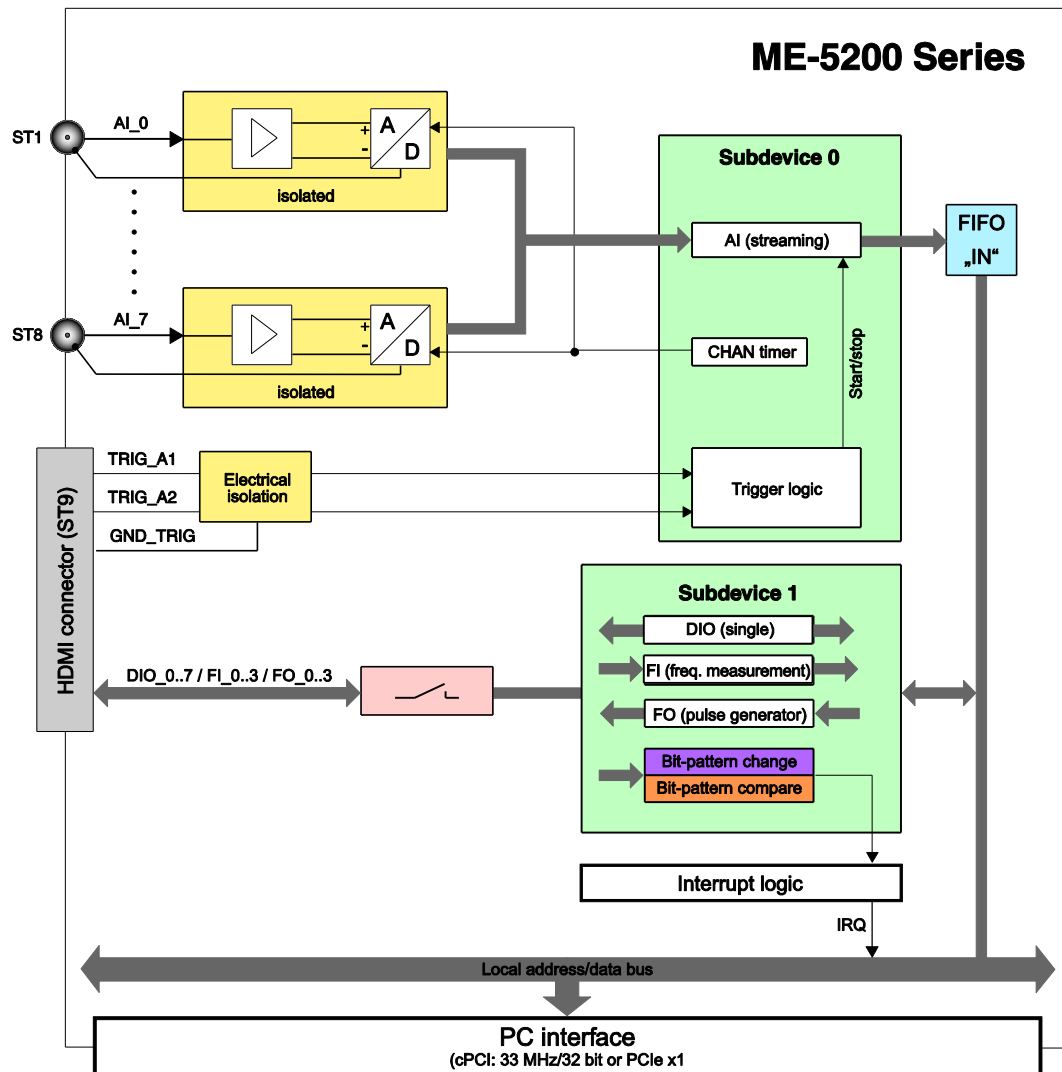

Diagram 3: Block diagram of the ME-5200

Note: Either 4 analog inputs (ST1..4) or 8 (ST..8) are available, depending on the model.

The pins assignment for the HDMI connector (ST9) can be found in the appendix (see “Pinout” on page 39). You will find a description of the circuitry of the individual function groups in the following chapters. Please read chapter 4 from page 23 for operation modes and programming.

3.2 ME-5200 cPCI

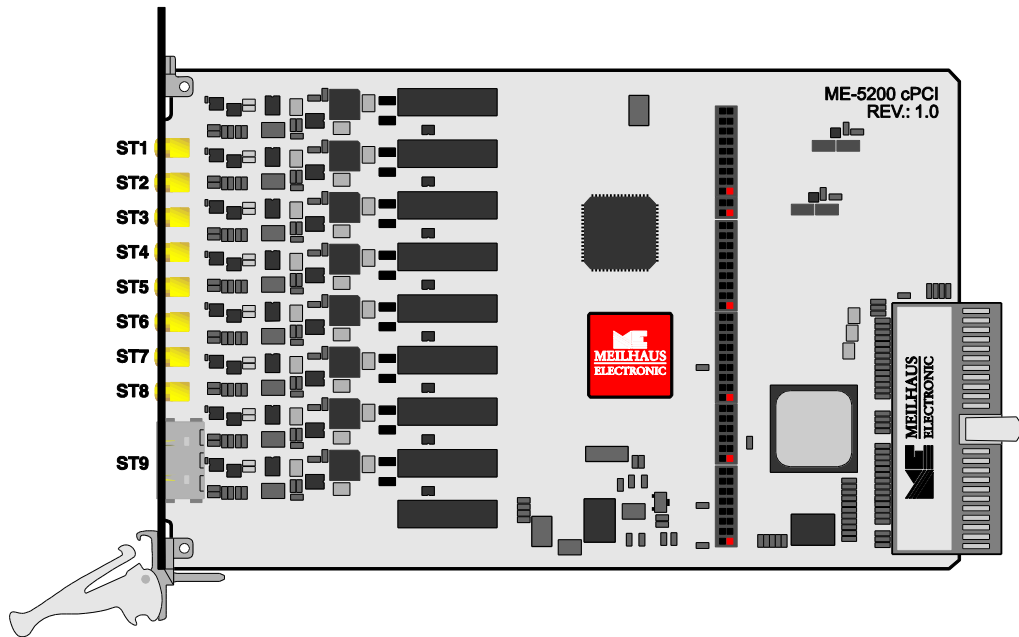

Diagram 4: ME-5200 cPCI

3.3 ME-5200 PCIe

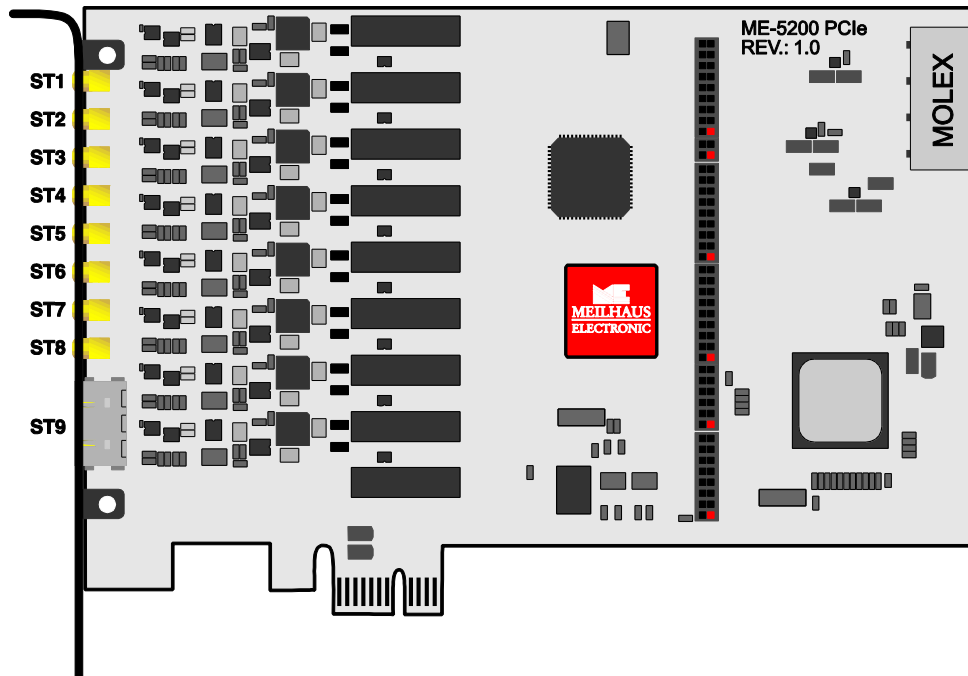

Diagram 5: ME-5200 PCIe

3.4 A/D Section

Depending on the model, the boards in the ME-5200 family comprise 4 or 8 fully differential analog input channels. All the A/D channels are electrically isolated from each other, and from the PC ground, up to 300 V. Depending on which A/D-converter is fitted, the maximum sample rate for the 18-bit versions lies between 250 kS/s and 1.6 MS/s, while for the 16-bit versions it is between 250 kS/s and 2 MS/s. All of the analog channels are sampled synchronously. A 32-bit CHAN timer is available for the timer-controlled conversion.

Please read chapter 4.1 from page 25 for programming the different operation modes.

3.4.1 Differential Inputs

Differential measurements can be taken with each channel independently, without a common ground reference. The advantage of differential measurement lies in the high degree to which common mode interference is suppressed. Each input channel has a positive and a negative input.

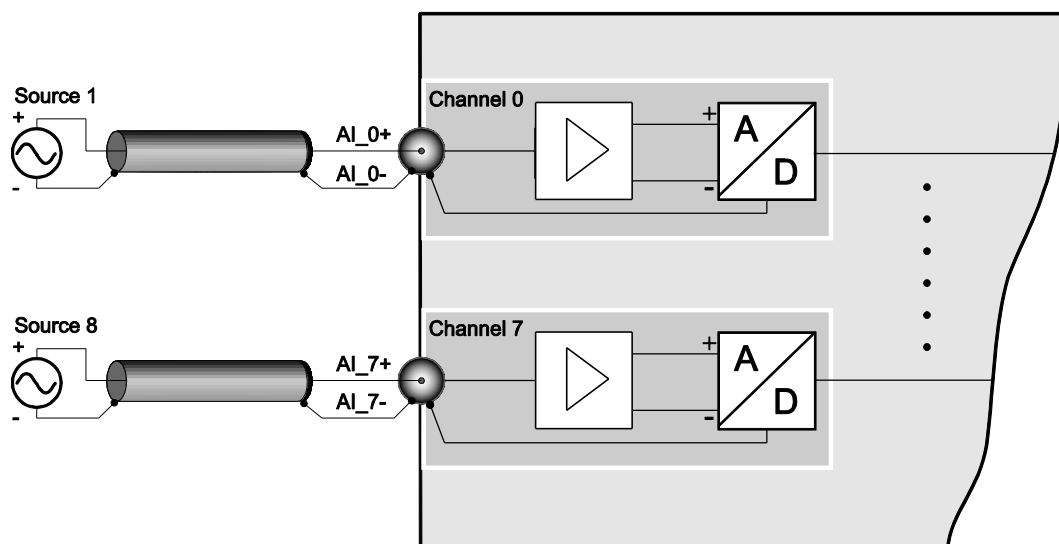

Diagram 6: Wiring the differential inputs

All the channels are decoupled by high-resistance input stages. For the standard version applies:

- Input impedance: $R_i = \text{typ. } 600 \text{ M}\Omega$, $C_i = \text{typ. } 5 \text{ pF}$



Observe the maximum permitted voltage at the analog inputs (see the specifications on page 33), otherwise the board may be irreversibly damaged!

3.4.1.1 Input Voltage Ranges

An input voltage range with a resolution of 16 or 18 bits is available on the boards of the ME-5200 series. The standard parameters are $-10.4\text{ V} \dots (+10.4\text{ V} - 1\text{ LSB})$. The input voltage range can be extended to $-104\text{ V} (+104\text{ V} - 1\text{ LSB})$ in combination with the “E” option.

The following (linearized) curve applies:

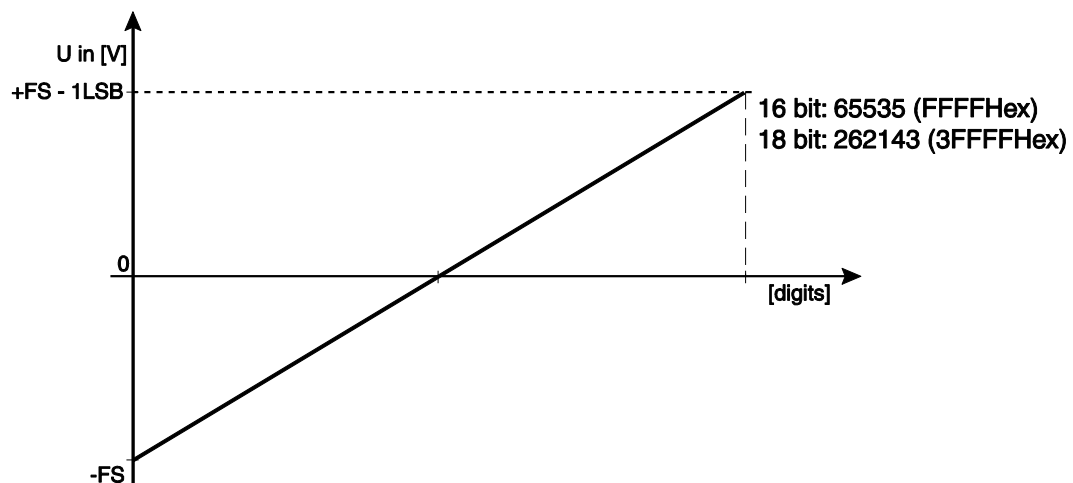

Diagram 7: Characteristic curve for input voltage range

(“FS” stands for “Full Scale” in the relevant measuring range; “LSB” stands for the least significant bit of the A/D conversion).

Note that the theoretical value for full-scale in each measuring range is usually only reached approximately (see also the specifications on page 33).

The following options are available to be able to match the input stage of the individual channels optimally to your application.

3.4.1.2 Optional Input Circuitry

When you order your board you can choose between the following input circuits, for which there is an additional charge, to suit your application.

For comparison, the standard “S” version is also listed (the “S” suffix is not included in the model identification):

| Option | Impedance R_i/C_i | SNR ¹⁾ | Bandwidth | Input Voltage Range |
|--------------------|--------------------------|-------------------|------------------------|-----------------------------|
| „S“ (standard) | > 100 M Ω /5 pF | 103.6 dB | 920 kHz | ± 10.4 V |
| „E“ | 200 k Ω /2 pF | 103.6 dB | 750 kHz | ± 104 V |
| „F“ | > 100 M Ω /100 pF | 105.5 dB | 700 kHz | ± 10.4 V |
| „T“ ⁽²⁾ | 1 M Ω /15 pF | 103.6 dB | 750 kHz ⁽³⁾ | ± 10.4 V ⁽²⁾ |

Table 3: Hardware options for the ME-5200 series

1) Signal-to-noise-ratio (SNR) indicates the ratio between the signal and noise levels of the individual channels. Measure with the 18-bit version, a sampling rate of 1 MS/s and using 1 kilo-samples.

2) depending on the probe being used. „x1“: ± 10.4 V, „x10“: ± 104 V, „x100“: ± 1040 V.

3) with „x10“ sampling probe.

If needed, the board, or some of its channels, can also be retrofitted by our service department. For this purpose please contact our Support Department (support@meilhaus.com).

3.4.1.2.1 Option “E” – Extended Input Voltage Range

The “E” option has an extended input voltage range of up to ± 104 V. for applications in the electrical mobility field, for example.

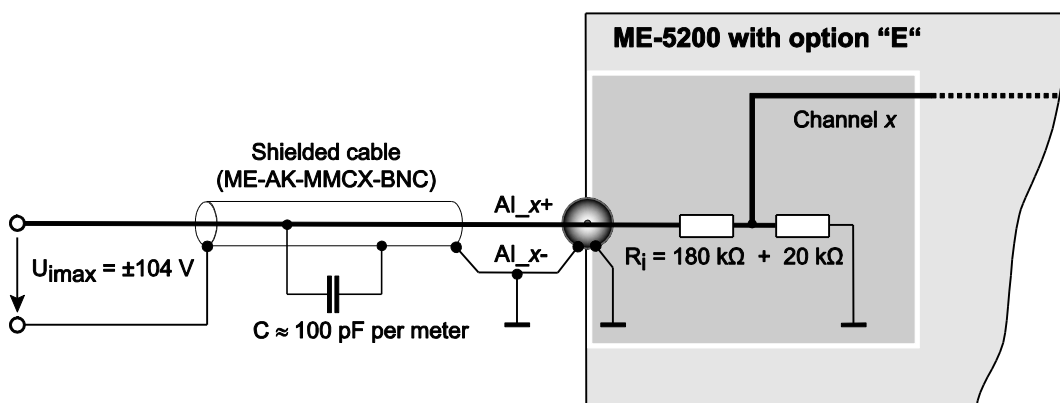

Diagram 8: Input circuitry for option “E”

The voltage at the analog inputs must not exceed ± 150 V, otherwise the card will be irreversibly damaged!

3.4.1.2.2 Option “F”-Signal Analysis

The “F” option is ideal for signal analysis, particularly when a high signal-to-noise is required (only for the ME-528x with 18-bit resolution).

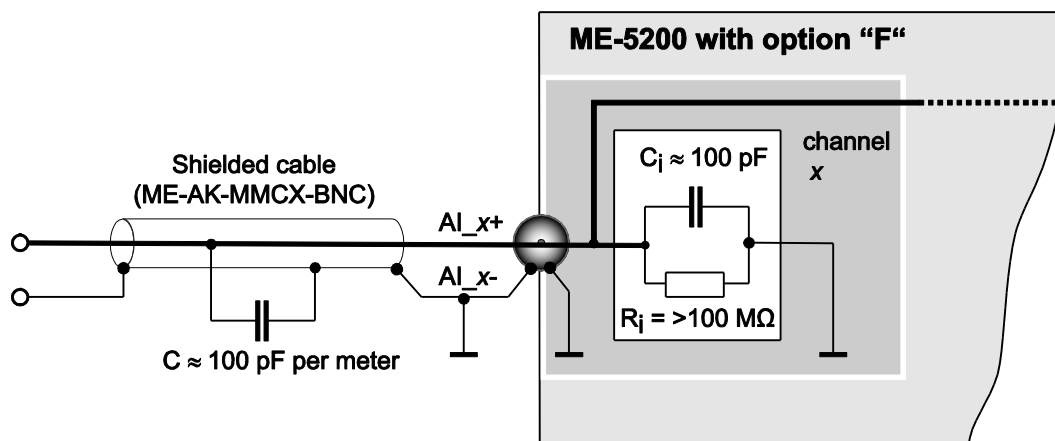

Diagram 9: Input circuitry for option "F"

3.4.1.2.3 Option “T” – Probe Adaption

The “T” option offers adaption of the impedance for standard oscilloscope probes.

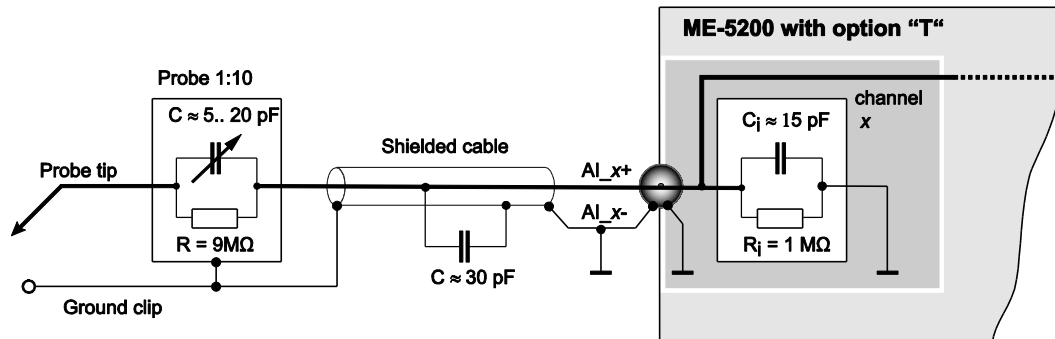

Diagram 10: Input circuitry for option "T"

3.4.2 External Trigger A/D Section

All the models in the ME-5200 series have two digital trigger inputs for the A/D section.

3.4.2.1 Edge Detection

For each of the two digital trigger inputs you can independently specify wherever triggering is to take place on a rising edge, a falling edge, or on any edge (i.e. either by a rising or falling edge).

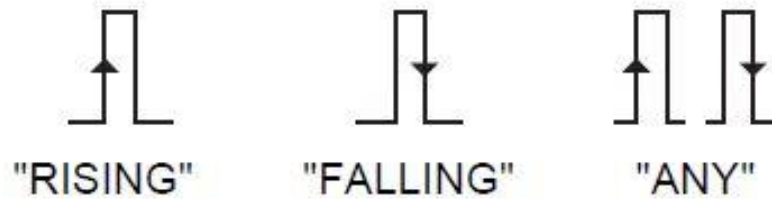

Diagram 11: Trigger edges

3.4.2.2 Digital Trigger Inputs

The digital trigger inputs TRIG_A1 and TRIG_A2 can be used for externally triggering the A/D section. The trigger conditions for starting and stopping the analog acquisition can thus be configured very flexibly. See also diagram 12 on page 19 and diagram 20 on page 35.

The trigger inputs are designed for a high-level of +2..5 V. The trigger signal requires a ground reference to GND_TRIG, but is, however, electrically isolated from the PC ground up to max. 42 V.

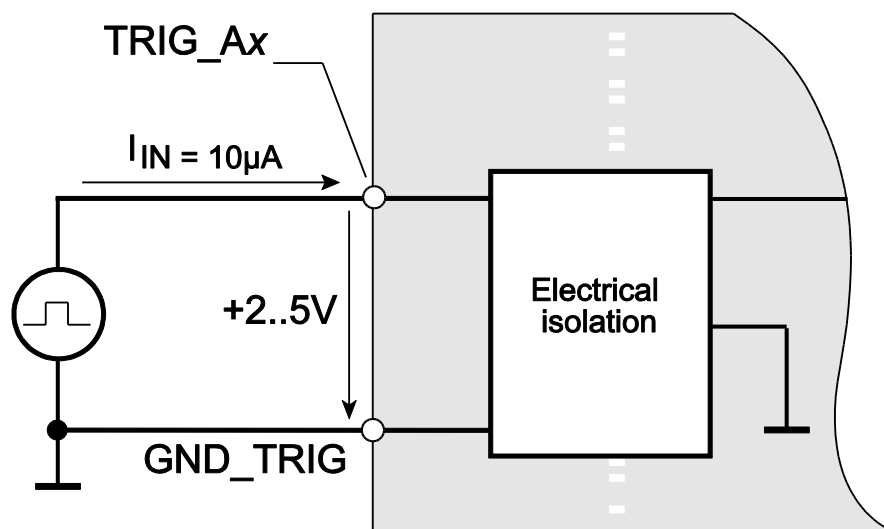

Diagram 12: Digital trigger circuitry

3.5 Digital-I/O Section

The ME-5200 incorporates an 8-bit digital-I/O port (subdevice 1). This subdevice is configured in the “single” operation mode. The direction of the port is defined in software. Immediately after powering up, the port is configured as an input.

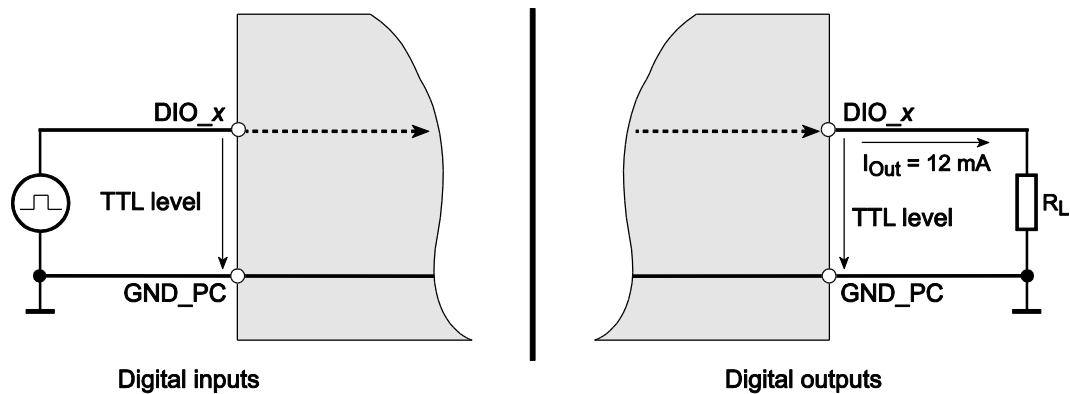

Diagram 13: Wiring the digital inputs/outputs

Please read chapter 4.1 from page 25 for programming the different operation modes.

3.5.1 Digital Inputs

When wiring as inputs, note that the voltage levels must be observed (see the specifications on page 33) and that a reference to the PC ground (GND_PC) must be established (see Diagram 13).

3.5.2 Digital Outputs

When wiring as outputs, note that the voltage levels must be observed (see the specifications on page 33) and that a reference to the PC ground (GND_PC) must be established (see Diagram 13).

$$I_{\text{out}} = I_{\text{OL}} = I_{\text{OH}} = 12 \text{ mA per pin.}$$

3.6 Frequency Input/Output

The concept of the “configurable subdevices” of the ME-5200 series gives you the option of using individual subdevices with an alternative functionality. The associated configuration is carried out with the ME-iDC configuration tool before you launch your application.

The following channels are available as alternatives:

- Frequency measurement (FI=“Frequency Input”)
 - 4 independent inputs for measuring the frequency and duty cycle of rectangular signals (max. 5.5 MHz).
- or
- Pulse generator (FO=“Frequency Output”):
 - 4 independent outputs for the output of a periodic rectangular signal at up to 5.5 MHz with a variable duty cycle.

The associated pins are identified as FI_x or FO_x in the terminal assignment on page 48. In this configuration, the remaining inputs/outputs of the digital ports cannot be used.

Note the level of the unused pins DIO_4..7 in the “Pulse generator” (FO) configuration. They are connected to ground!

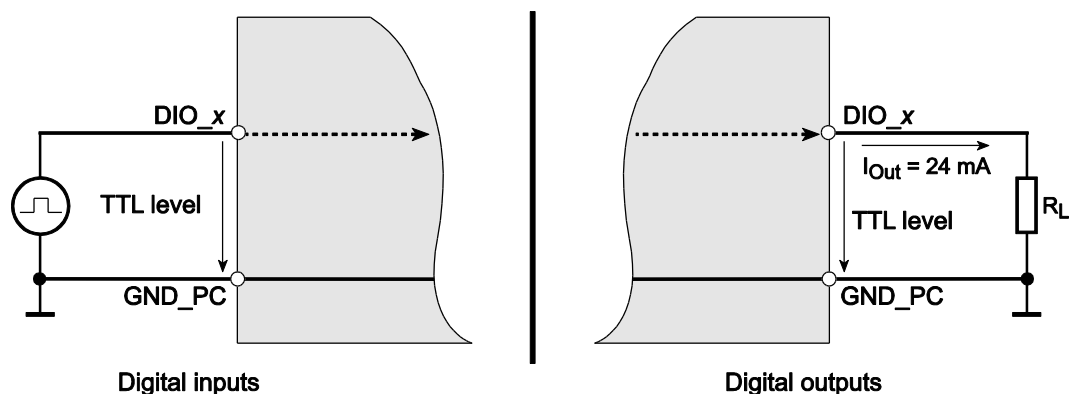

Diagram 14: Wiring the frequency inputs/outputs

The specifications for the digital-I/O ports apply to the wiring of the inputs and outputs. A reference to the PC ground (GND_PC) must always be established. The maximum output current is $I_{Out} = I_{OL} = I_{OH} = 12 \text{ mA}$.

The frequency counters and pulse generators are configured by software. Please read chapter 4.1 on page 25 for programming the frequency input/output.

3.7 External Interrupt

If required, you can also monitor the bit-pattern of a digital input port. The “bit-pattern change” and “bit-pattern compare” modes are available. As soon as the specified event occurs, an interrupt is issued and passed directly to the PC.

The digital inputs/outputs are programmed in the single operation mode. The interrupt handling is carried out with the *meIOIrq...* functions; see also chapter 4.3 on page 30.

4 Programming

For programming the device please use the Meilhaus Electronic Intelligent Driver System (ME-iDS) included in your package. The ME-iDS is a unique driver system covering different devices and operating systems. It supports Windows 2000 and higher and contains a universal function library (API) for all common programming languages (the extent of the current software support can be found in the README-files of the ME-iDS).

A detailed description of the functions can be found in the ME-iDS manual (see CD/DVD enclosed or online: www.meilhaus.de/download/ME-iDS).

Further details regarding the assignment of the subdevices and device specific arguments can be found in the help file (help file format under Windows, *.chm) which can be accessed via the „ME-iDS Control Center“ in the info area of the task bar (as a rule in the lower right corner of the screen) or via the Windows start menu.

The basic boards of the ME-5200 series are devices with two "sub-devices", beginning with the index "0".

The functionality of the subdevices can be specified by the user through selecting a pre-defined configuration. The desired configuration is selected by the ME-iDC configuration tool before your application starts. Using the standard configuration, (ID 0), the board is ready to operate immediately. You will find an overview of the available configurations in the following tables:

Subdevice Configurations ME-5200

| Subdevice Type... | ...Subtype | I/Os | ID of the Configuration |
|-----------------------------------|------------|---------------------|-------------------------|
| Subdevice 0 (AI) | | | |
| Analog input (AI) | streaming | 4 or 8 channels | 0* |
| Subdevice 1 (DIO, FI, FO) | | | |
| Digital input/output (DIO) | single | 8-bit bidirectional | 0* |
| Frequency input (FI) | single | 4 channels | 1 |
| Frequency output (FO) | single | 4 channels | 2 |

Table 4: Subdevice configurations of the ME-5200

*Standard configuration at shipment. The most recently selected configuration in the ME-iDC is stored in a non-volatile memory on the board, and is automatically loaded after a restart.

Depending on requirements, you can select from the following operation modes:

- **Single:** Individual values can be read or written in this operating mode.
- **Streaming:** Data is read in/output in this operation mode via a FIFO. It is possible to choose between a timer and/or external trigger signals for timing control. A large number of trigger options, with which you can define start and stop conditions, are available. See chapter 4.2.1 starting on page 28.
- **Interrupt:** For the interrupt handling in the bit-pattern change and bit-pattern compare modes (see chapter 4.3.1 starting on page 31).

| Operation mode | Speed | Trigger |
|--|---|--|
| Single (AI) | single value | input/output via software or by external trigger |
| Single (DIO) | single value | input/output via software |
| Stream timer (AI) | sampling rate up to 2 MS/s (depending on the model) | start/stop by software or by external Trigger |
| Stream trigger sample | | |
| Stream trigger list | | |
| Interrupt (Bit-pattern detection) | $f_{\text{IRQmax.}} = 10 \text{ kHz}$ | ext. trigger signal at a digital input/output port |

Table 5: Operation modes summary

Comprehensive timing diagrams can be found in the ME-iDS manual.

4.1 Single Operation Mode

Individual values can be read or written in this operating mode.

4.1.1 Analog Input

The input of individual analog values is carried out in the single operation mode.

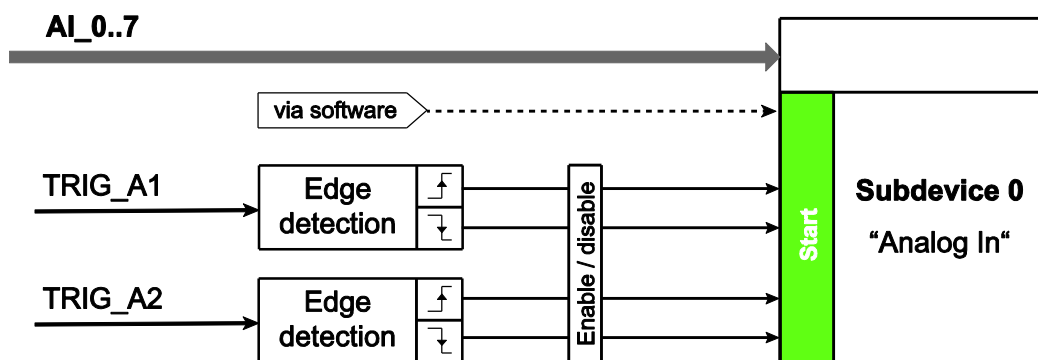

Diagram 15: Analog input in single mode operation

Note: The analog input channels (subdevice 0) of the ME-5200 can be triggered externally via TRIG_A1 and TRIG_A2.

Please observe the ME-iDS manual and the ME-iDS help file (*.chm) for the procedure. You can open both of these documents through the “ME-iDS Control Center” or through the Windows Start menu.

Please read chapter 3.4 on page 15 for wiring of the analog inputs.

4.1.2 Digital Input/Output

The input/output of individual digital values is carried out in the single operation mode. The digital-I/O port of the ME-5200 is always addressed as a subdevice of type ME_TYPE_DIO, sub-type ME_SUBTYPE_SINGLE. The subdevice can optionally be configured as an 8-bit input or output port.



Diagram 16: Digital input/output in single operation mode

Notes:

- The digital port (subdevice 1) of the ME-5200 can be used bidirectionally.
- Immediately after powering up, the bidirectional digital port is configured as an input.
- A port that is configured as an output can also be read back!

Please observe the ME-iDS manual and the ME-iDS help file (*.chm) for the procedure. You can open both of these documents through

Please read chapter 3.5 on page 15 for the wiring of the digital I/Os.

4.1.3 Frequency Input/Output

Before you can use the frequency measurement or pulse generator modes, it is necessary, before opening your application, to run the ME-iDC configuration tool in order to specify the configuration for the corresponding subdevice (see also Table 4 on page 23).

The programming of the frequency measurement and the pulse generator is always done in the single operation mode. The subtype of the subdevice is always ME_SUBTYPE_SINGLE.



Diagram 17: Frequency input/output in single operation mode

Please read the ME-iDS manual and the ME-iDS help file (*.chm) carefully prior to programming. You can open both of these documents through the “ME-iDS Control Center” or through the Windows Start menu.

Two variables are introduced to describe the rectangular signal, and apply equally to input and output. One value indicates the period T , while the other value provides the duration of the pulse of the first phase of the period t_{1p} . For frequency measurement, the

measurement starts with the first rising edge, and finishes with the next rising edge. The falling edge that lies between them defines the end of the first phase. In pulse generator mode, output normally starts with a high level, changing to the low level when the first phase has elapsed.

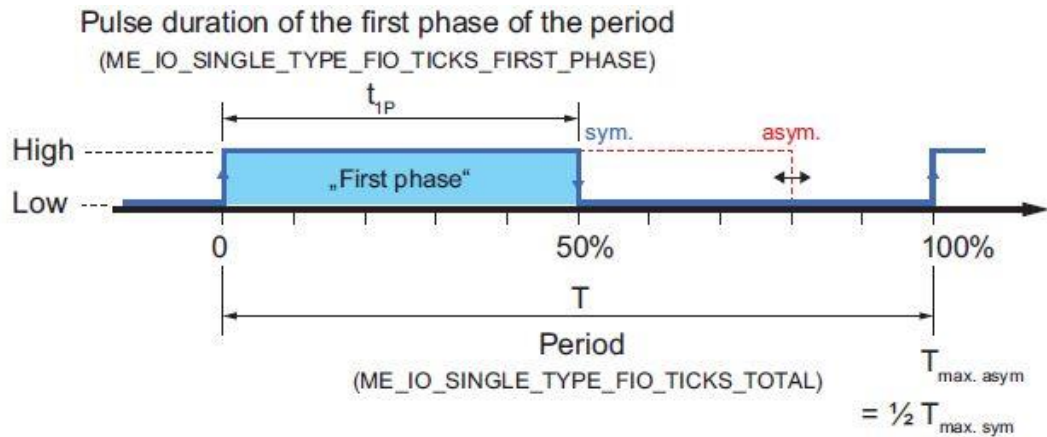

Diagram 18: Signal definition

The time reference is provided by a 66 MHz counter. It is configured using the *meIOSingleConfig()* function. A period of 15.15 ns follows from this, and is defined as the smallest unit of time. It is referred to below as "1 tick". The resolution for T and t_{1P} is therefore 1 tick (see also the specifications on page 33).

Note that the value of the maximum period $T_{\max.}$ depends on the duty cycle. A distinction is drawn between rectangular signals with an asymmetrical duty cycle $T_{\max. \text{ asym.}}$ and a symmetrical duty cycle $T_{\max. \text{ sym.}}$. The figures for the ME-5200 are:

$$T_{\max. \text{ asym.}} = 32.5 \text{ s (0.03 Hz)}; T_{\max. \text{ sym.}} = 65 \text{ s (0.015 Hz)}$$

The wiring of the frequency inputs/outputs can be found in chapter 3.6 on page 37.

4.1.3.1 Frequency Measurement

With the frequency measurement operating mode (FI="Frequency Input") you can determine the period or frequency, and the duty cycle of rectangular signals up to about 5.5 MHz. The resolution is 1 tick = 15.15 ns. The measurement always starts at a rising edge. On the ME-5200, all 4 frequency measuring channels (FI_0...3) are addressed as subdevices of type ME_TYPE_FI, sub-type ME_SUBTYPE_SINGLE. Each channel can be programmed independently

Note: If you require the frequency and duty cycle magnitudes you want, these can easily be calculated from the values returned for `<pdTime>`. The formula is:

Frequency [Hz] = 1/period [s]

Duty cycle [%] = („duration of the first phase of the period“ [s]/period [s] x 100.

4.1.3.2 Pulse Generator

In the pulse generator operating mode (FO = "Frequency Output") you can output rectangular signals with a variable duty cycle at frequencies of up to 5.5 MHz and with a resolution of 1 tick. On the ME-5200, all 4 pulse generator channels (FO_0...3) are addressed as subdevices of type ME_TYPE_FO, sub-type ME_SUBTYPE_SINGLE. Each channel can be programmed independently

The first phase of the rectangular signal is "high" by default. By setting the ME_IO_SINGLE_TYPE_FO_START_LOW flag it is also possible to start the output with a "low" level.

Note: An output channel can also be read back!

4.2 Streaming Mode Operation

4.2.1 Analog Input

The programming of the timer-controlled input via FIFO is carried out in the streaming operation modes. A continuous transfer bandwidth of up to 30 MHz is available between the PC and the ME-5200.

Please observe the ME-iDS manual and the ME-iDS help file (*.chm) for the **procedure**. You can open both of these documents through the "ME-iDS Control Center" or through the Windows Start menu.

4.2.1.1 Stream Timer

In this operation mode the values are acquired under the control of a timer. This allows up to 8 analog input channels to be sampled simultaneously at up to 2 MS/s. The sampling rate is determined by the CHAN timer. If required, the acquisition can also be started or stopped with an external trigger signal at TRIG_A1 or TRIG_A2. Note here that the offset time t_{Off} must allow the settling time of the hardware (see the parameter: `<iAcqStartTicks>`). A SCAN timer is not available on the ME-5200 – please enter a 0 into the corresponding parameters.

4.2.1.2 Stream Trigger Sample

In this operation mode individual values can be acquired under the control of the external trigger signals TRIG_A1 and/or TRIG_A2. For each trigger pulse one value is acquired according to the channel list. The pulse rate of the two inputs must not exceed the maximum sampling rate of your ME-5200 model. Please pass 0 for the CHAN timer.

4.2.1.3 External Trigger

The trigger conditions for starting and stopping the streaming operation mode can be selected very flexibly. It is thus possible to enable one or more trigger inputs, with specification of the desired trigger edge (rising, falling, or any). All the enabled trigger inputs are logically ORed together. This means that the first edge to arrive that meets the trigger condition starts or stops the input/output operation, according to the selected operation mode (stream timer or stream trigger sample). In other words, any desired change in the bit-pattern can be used as the trigger event for the subdevice concerned.

The trigger inputs TRIG_A1 and/or TRIG_A2 can be used for subdevice 0 (see Diagram 19).

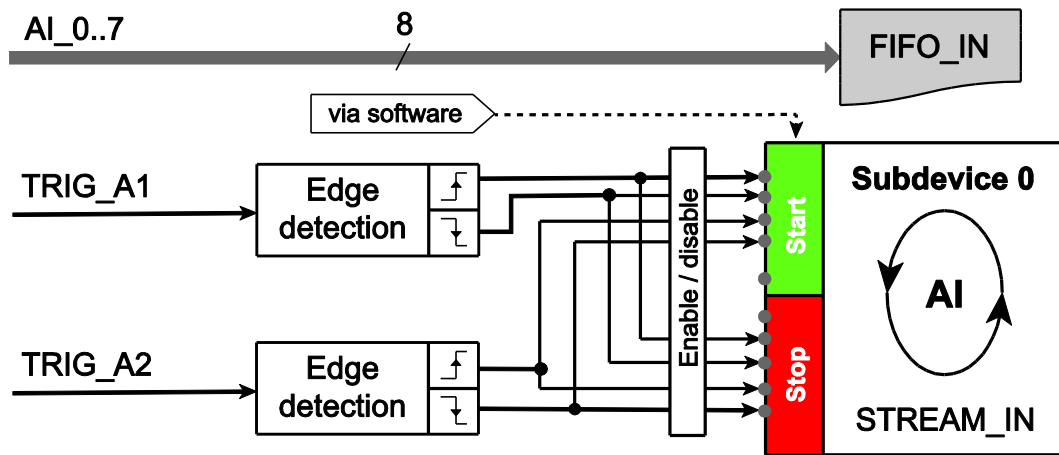

Diagram 19: Trigger in streaming mode

4.3 Interrupt Operation

The bit-pattern of the 8-bit-wide digital-I/O port can be monitored on the boards of the ME-5200 series. You can choose between the bit-pattern compare and bit-pattern change modes to suit the application. As soon as the first edge that meets the trigger condition arrives, an interrupt is issued and passed directly to the PC.

The digital inputs/outputs are programmed in the single operation mode. The subdevice must be of type ME_TYPE_DIO, and must be configured as an input. The interrupt handling is carried out with the *meIOIrq.* functions.

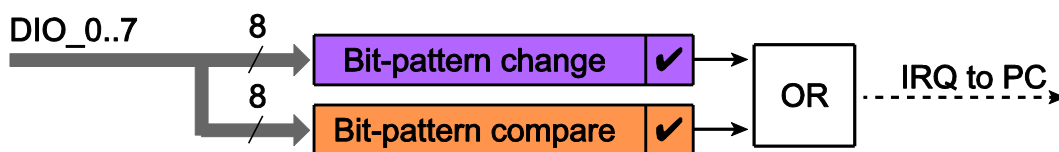

Diagram 20: Interrupt options

Please observe the ME-iDS manual and the ME-iDS help file (*.chm) for the **procedure**. You can open both of these documents through the “ME-iDS Control Center” or through the Windows Start menu.

4.3.1 Bit-Pattern Change

In the bit-pattern change mode, one or more bits that are to be monitored for a change of state can be defined (masked). A 32-bit-wide argument per subdevice contains the mask. For each input pin both one bit for rising edge and one bit for falling edge is available. If the state of at least one bit masked with a “1” changes (0 → 1 or 1 → 0), an interrupt is issued (see Diagram 21).

In what is known as the “extended format” of interrupt handling (see the ME-iDS manual), two bits are available for the interrupt status of each pin. One is for the rising edge, and one for the falling edge. The bits for the falling edges are assigned to the bit b7...0, while the bits for the rising edges are assigned to the bits b23...16.

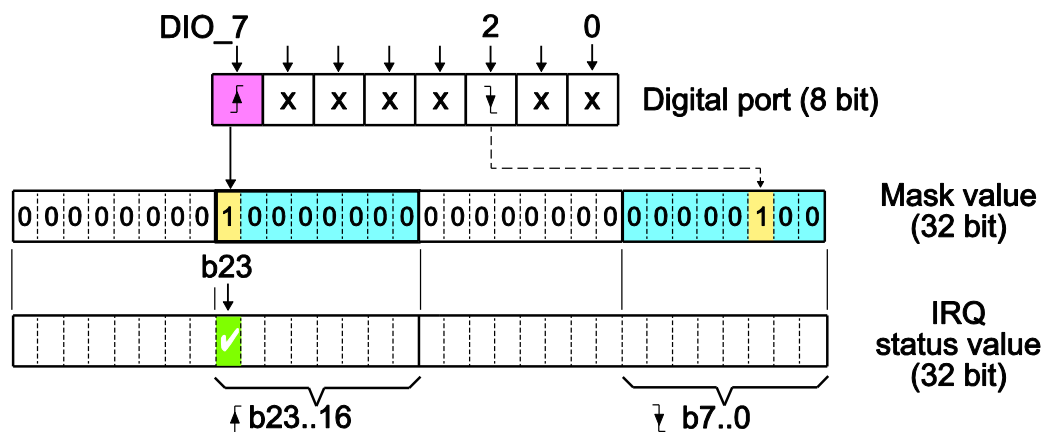

Diagram 21: Bit-pattern change

Example (see diagram 22):

By writing the value 00800004 Hex as a mask value (see parameter `<iIrqArg>` of the function `meIOIrqStart()`, bit 2 is monitored for a falling edge, and bit 7 for a rising edge. A rising edge now is to arrive at bit 7, so that an interrupt is issued and in the interrupt status value bit b23 returns “1”. Any edges that might arrive at pins labelled with an “X” are ignored. Only the change in state of a pin whose edge is set to “1” in the parameter `<iIrqArg>` can issue an interrupt.

The interrupt event is evaluated with the function `meIOIrqWait()`. We recommend using what is known as the “extended format” to obtain detailed information about the triggering edge.

4.3.2 Bit-Pattern Compare

In the “bit-pattern compare” mode, the bit-pattern of digital inputs can be monitored for equality or inequality. The compare bit-pattern of the corresponding subdevice is used as reference. If the state changes from unequal or from equal to unequal, an interrupt is generated (see Diagram 22).

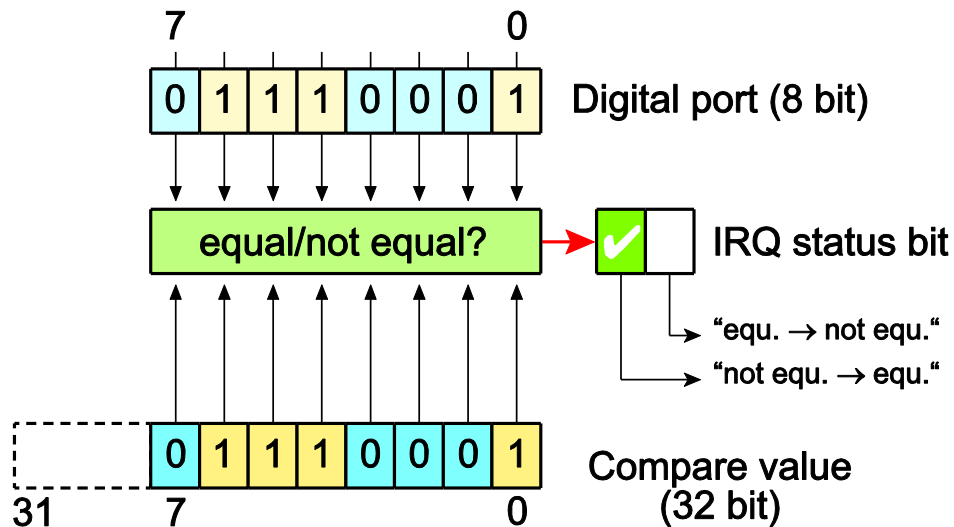

Diagram 22: Bit-pattern compare

5 Appendix

A Specification

PC Interface

| | |
|-----------------|--|
| PCI-Express-bus | 32 bit, 33 MHz, 3.3 V, PCI-Express x 1 specification version 2.0 |
| CompactPCI-bus | 32 bit, 33 MHz, 5 V, PICMG 2.0 R3.0 |
| Plug&Play | is fully supported |

Analog Inputs

| Measured Quantity/Criterion | Condition/Explanation | Value |
|---------------------------------|-----------------------------|---|
| Number of channels | subdevice 0 (streaming) | 4 or 8 analog inputs |
| Operation modes | single | reading/writing triggered by software or externally |
| | stream timer | timer-controlled reading/writing of the values via FIFO |
| | stream trigger sample | trigger-controlled reading/writing of the values via FIFO |
| | interrupt | bit-pattern change, bit-pattern compare |
| FIFO size | FIFO_IN | 8192 Values |
| Transfer rate in streaming mode | between the ME-5200 and PC | max. 25 MHz (cPCI) or 30 MHz (PCIe) (system-dependent)* |
| Measured Quantity/Criterion | Condition/Explanation | Value |
| Timer (CHAN time)* | ME-5265 (2.0 MS/s) | 500 ns...65 s (33..FFFFFFFFHex Ticks) |
| | ME-5284 (1.6 MS/s) | 621 ns...65 s (41..FFFFFFFFHex Ticks) |
| | ME-5283, ME-5263 (1.0 MS/s) | 1 μ s...65 s (66..FFFFFFFFHex Ticks) |

| | | |
|------------------------------------|------------------------------|--|
| | ME-5282, ME-5262 (500 kS/s) | 2 μ s...65 s (132..FFFFFFFFHex Ticks) |
| | ME-5281, ME-5261 (250 kS/s) | 4 μ s...65 s (264..FFFFFFFFHex Ticks) |
| Timer resolution | programmable | 15.15 ns (1 Tick) |
| External trigger inputs | for the analog input section | TRIG_A1, TRIG_A2 |
| External trigger edges | | rising, falling, any |
| Sampling rate max. | ME-5284 (synchronous) | 1.6 MS/s, 18 bit |
| | ME-5283 (synchronous) | 1.0 MS/s, 18 bit |
| | ME-5282 (synchronous) | 500 kS/s, 18 bit |
| | ME-5281 (synchronous) | 250 kS/s, 18 bit |
| | ME-5265 (synchronous) | 2.0 MS/s, 16 bit |
| | ME-5263 (synchronous) | 1.0 MS/s, 16 bit |
| | ME-5262 (synchronous) | 500 kS/s, 16 bit |
| | ME-5261 (synchronous) | 250 kS/s, 16 bit |
| Resolution | ME-528x, option S, T, F | 18 bit (79.3 μ V) |
| | ME-528x, option E | 18 bit (793 μ V) |
| | ME-526x, option S, T | 16 bit (317 μ V) |
| | ME-526x, option E | 16 bit (3174 μ V) |
| Input voltage range | option S | \pm 10.4 V |
| | option T | \pm 10.4 V ²⁾ |
| | option E | \pm 104 V |
| | option F | \pm 10.4 V |
| Measured Quantity/Criterion | Condition/Explanation | Value |
| Max. input voltage | option S | \pm 20 V |
| | option T | \pm 13 V |
| | option E | \pm 160 V |
| | option F | \pm 20 V |
| Input impedance | option S | R _i > 100 M Ω , C _i =5 pF |
| | option T | R _i = 1 M Ω , C _i = 15 pF |
| | option E | R _i =200 k Ω , C _i =2 pF |

| | | |
|--------------------------------|--|---|
| | option F | $R_i > 100 \text{ M}\Omega$, $C_i = 100 \text{ pF}$ |
| Input current | option S | 40 nA |
| | option T | 10 μA |
| | option E | 500 μA |
| | option F | 40 nA |
| Bandwidth (3 dB) | option S (500kS/s. 2,0 MS/s) | 920 kHz |
| | option T (500kS/s. 2,0 MS/s) | 750 kHz ³⁾ |
| | option E (500kS/s. 2.0 MS/s) | 750 kHz |
| | option F (500kS/s. 1.6 MS/s) | 700 kHz |
| | option S, T, E (250 kS/s) | 700 kHz |
| Bandwidth (0.1 dB flatness) | option S (500 kS/s. 2.0MS/s) | 130 kHz |
| | option T (500 kS/s. 2.0 MS/s) | 100 kHz ³⁾ |
| | option E (500 kS/s. 2.0 MS/s) | 100 kHz |
| | option F (500 kS/s. 1.6 MS/s) | 80 kHz |
| | option S, T, E (250 kS/s) | 80 kHz |
| SNR at 1 MS/s and 10 kS | option S, T, E (18 bit, 1.6MS/s) | 103.6 dB _{FS, RMS} |
| | option F (18 bit, 1.6 MS/s) | 105.5 dB _{FS, RMS} |
| | option S, T, E F (16 bit, 250 kS/s. 2.0 MS/s) | 90 dB _{FS, RMS} |
| Coupling capacitance | | 23 nF |
| Isolation voltage | channel to channel, channel to PC ground | max. 300 VDC |
| Reference ground | fully differential channels | not required |

¹⁾Signal-to-noise ratio (SNR) indicates the ratio between the signal and noise levels of the individual channels. Measured with the 18-bit version, a sampling rate of 1 MS/s and using 10 kS.

²⁾The measuring range depends on the probe in use: „x1“: $\pm 10.4 \text{ V}$, „x10“: $\pm 104 \text{ V}$, „x100“: $\pm 1040 \text{ V}$.

³⁾with „x10“-sampling probe.

Digital Trigger Inputs for the A/D Section

| Measured Quantity/Criterion | Condition/Explanation | Value |
|-----------------------------|---|---------------------------------|
| Number | | 2 (TRIG_A1, TRIG_A2) |
| Max. trigger rate | applies to successive pulses of one of the two trigger inputs | max. sampling rate of the board |
| Max. input level | | -0,5.. +5.5 V |
| Input level U_{IL} | | max. 0.8 V |
| U_{IH} | | min. 2 V |
| Input current I_{IN} | | $\pm 10 \mu\text{A}$ |
| Delay time | | max. 30 ns |
| Isolation voltage | signal to GND_PC and GND_TRIG to GND_PC | max. 42 V |
| Reference ground | | GND_TRIG |

Digital Input/Output

| Measured Quantity/Criterion | Condition/Explanation | Value |
|-----------------------------|-------------------------------|--|
| Port | subdevice 1 | 8-bit bidirectional |
| Operation modes | single | software triggered reading/writing |
| | interrupt | monitoring the digital ports for a change in the bit-pattern or for a bit-pattern comparison |
| Input/output rate | (depends on the system) | software controlled |
| Max. input level | | -0.5.. +7.0 V |
| Input level U_{IL} | | max. 0.8 V |
| U_{IH} | | min. 2 V |
| Input current I_{IN} | | $\pm 10 \mu\text{A}$ |
| Output level U_{OL} | At $I_{OUT} = 12 \text{ mA}$ | max. 0.4 V |
| U_{OH} | At $I_{OUT} = -12 \text{ mA}$ | min. 2.8 V |
| Output current I_{OUT} | per pin | $\pm 12 \text{ mA}$ |
| Reference ground | | PC ground (GND_PC) |

Frequency Input/Output

| | |
|--------------|--|
| Availability | alternative subdevice configuration via ME-iDC |
| Signal form | rectangular |

Frequency Measuring Channels

| Measured Quantity/Criterion | Condition/Explanation | Value |
|-----------------------------|---|--|
| Reference ground | | PC ground (GND_PC) |
| Number of channels | (FI_0...3) | 4 inputs (TTL) |
| Input level | see digital I/O | |
| Input current | see digital I/O | |
| Period (T) | $T_{min.} = T_{min. asym.} = T_{min. sym.}$ $T_{max. asym.}$ $T_{max. sym.}$ | 181.81 ns (5.5 MHz) 32.5 s (0.03 Hz) 65 s (0.015 Hz) |
| Duty cycle | variable, depending on T | measurable in steps of 1 tick |
| Resolution | 1 Tick | 15.15 ns |
| Accuracy | | 15.15 ns |
| Operation modes | | Single |

Pulse Generator Channel

| Measured Quantity/Criterion | Condition/Explanation | Value |
|-----------------------------|--|--|
| Reference ground | | PC ground (GND_PC) |
| Number of channels | (FO_0...3) | 4 outputs (TTL) |
| Output level | see digital I/O | |
| Period (T) | $T_{min.} = T_{min. asym.} = T_{min. sym.}$ $T_{max. asym.}$ $T_{max. sym.}$ | 181.81 ns (5.5 MHz) 32.5 s (0.03 Hz) 65 s (0.015 Hz) |
| Duty cycle | variable depending on T | adjustable in steps of 1 tick |
| Resolution | 1 tick | 15.15 ns |
| Accuracy | | ± 15.15 ns |
| Operation modes | | single |

Interrupt

| Measured Quantity/Criterion | Condition/ Explanation | value |
|------------------------------------|-------------------------------|---|
| Interrupt sources | passed directly to the PC | bit-pattern change, bit-pattern compare |

General Data

| Measured Quantity/Criterion | Condition/ Explanation | Value |
|------------------------------------|----------------------------------|--|
| Power supply | CompactPCI | +5 V (via PCI-bus) |
| | PCI-Express | +3.3 V (via PCIe-bus), +5 V (via Molex-plug from PC power-supply-unit) |
| Current consumption | CompactPCI (idling current) | 3.3 V : 240 mA, 5 V : 570 mA |
| | CompactPCI (8 AI, 8 DIO 1MS/s) | 3.3 V : 650 mA, 5 V : 1.8 A |
| | PCI-Express (idling current) | 3,3 V : 370 mA, 5 V : 570 mA |
| | PCI-Express (8 AI, 8 DIO, 1MS/s) | 3,3 V : 770 mA, 5 V : 1,8 A |
| Board dimensions | CompactPCI | 3U CompactPCI boards |
| | PCI-Express | 162 mm x 98 mm |
| Connections | ST1..4 or ST1..8 | 4 or 8 MMCX coaxial sockets |
| | ST9 | HDMI connector, type HEC |
| Operating temperature | | 0...70 °C |
| Storage temperature | | -40...100 °C |
| Air humidity | | 20...55 % (non-condensing) |

| | |
|---------------|----|
| Certification | CE |
|---------------|----|

B Pinout

Note: „ME-5200“ stands for all the models in the ME-5200 series.

Legend for pinouts:

| Pin-name | Function |
|------------|---|
| AI_0..7+ | positive signal of the analog input channels (subdevice 0) |
| AI_0..7- | negative signal of the analog input channels (subdevice 0) |
| DIO_0..7 | digital input/output (subdevice 1) |
| FI_0..3 | frequency measurement inputs (subdevice 1, alternative configuration) |
| FO_0..3 | pulse generator outputs (subdevice 1, alternative configuration) |
| TRIG_A1 | first digital trigger input for AI section (referenced to GND_TRIG) |
| TRIG_A2 | second digital trigger input for AI section (referenced to GND_TRIG) |
| GND_TRIG | isolated ground for TRIG_A1 and TRIG_A2 |
| GND_PC | PC ground |
| „reserved“ | pins reserved for extensions |

These pins must not be connected, otherwise the board can be irreversibly damaged!



Note: the level of the unused pins DIO_4..7 in the “Frequency measurement” (FI) and “Pulse generator” (FO) configurations.

These pins are connected to ground!

B1 HDMI Connector (Digital I/O)

HDMI connector type HEC for digital I/Os (opt. FI/FO) and digital trigger inputs.

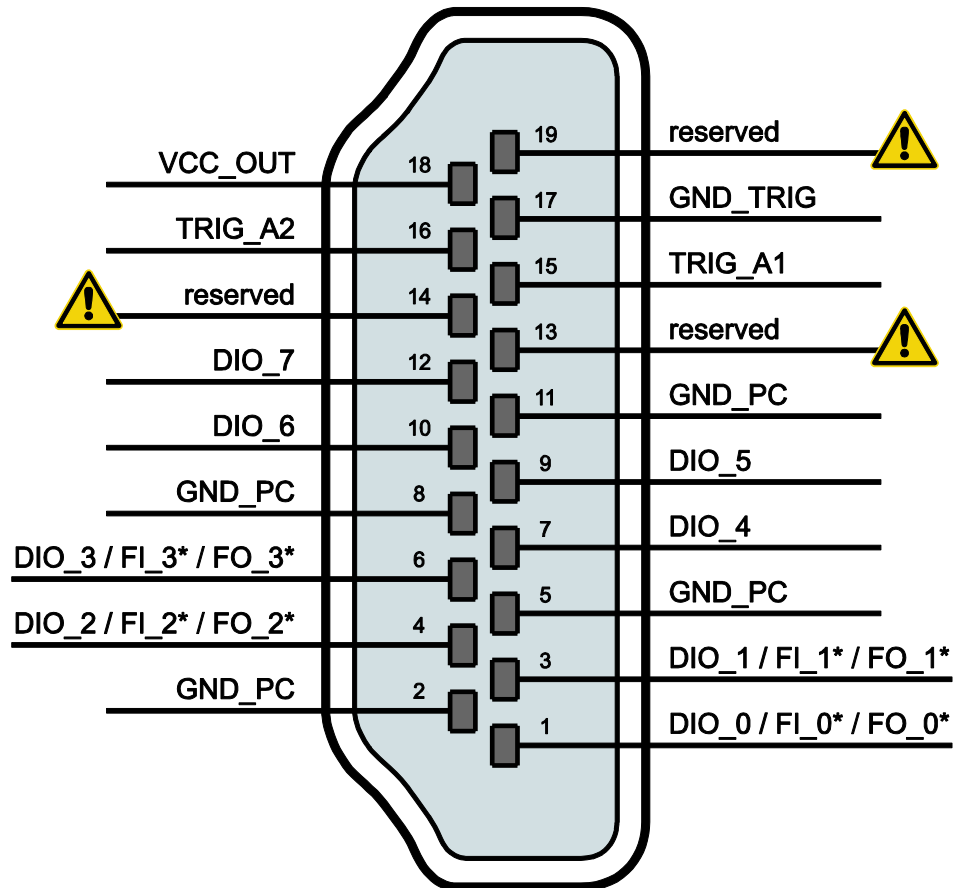

Diagram 23: HDMI connector of the ME-5200 series (ST9)

*It is only possible to use these pins as frequency measuring inputs (FI_x) or as pulse generator outputs (FO_x) after the relevant subdevice has been appropriately configured with the ME-iDC. The other pins of the relevant digital port can then no longer be used for digital input/output.



Reserved pins must not be connected, otherwise the board may be irreversibly damaged.

B2 Mounting bracket with analog inputs

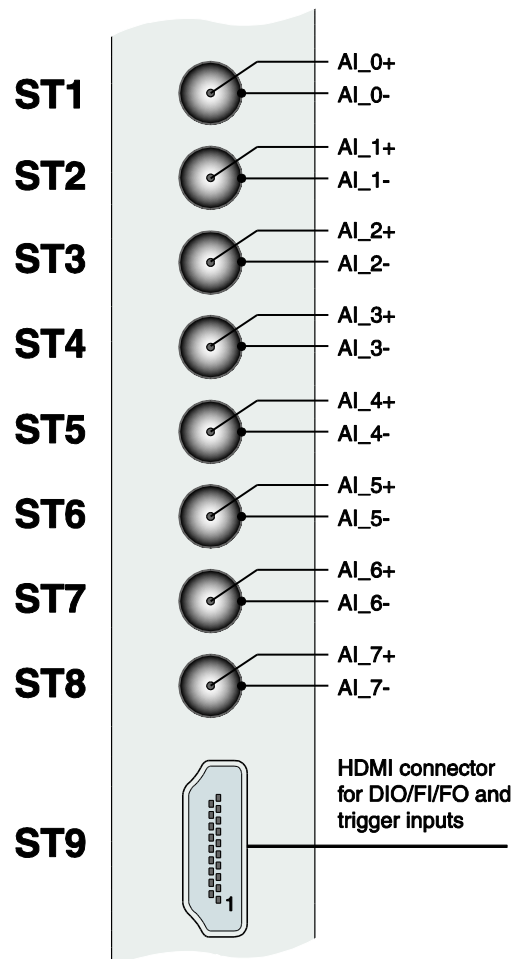

Diagram 24: Slot bracket of the ME-5200 series

Note: ST1..8 are MMCX coaxial-sockets. The number of analog inputs depends on the model.

B3 Terminal block for the ME-5200

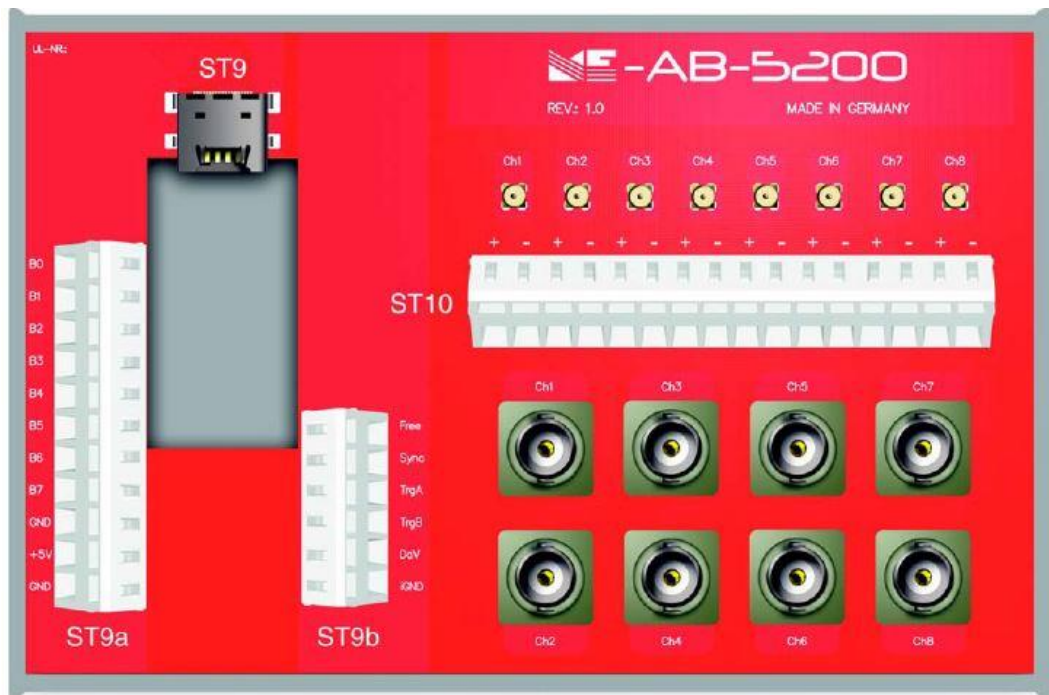

Diagram 25: ME-AB-5200

Signal assignments

| Signal Name (manual) | Label on Terminal Block | Signal Name (manual) | Label on Terminal Block |
|----------------------|-------------------------|----------------------|-------------------------|
| AI_0+/- | Ch1 | DIO_0..7 | B0..7 |
| AI_1+/- | Ch2 | reserved* | Free |
| AI_2+/- | Ch3 | reserved* | Sync |
| AI_3+/- | Ch4 | TRIG_A1 | TrgA |
| AI_4+/- | Ch5 | TRIG_A2 | TrgB |
| AI_5+/- | Ch6 | reserved* | DaV |
| AI_6+/- | Ch7 | GND_TRIG | iGND |
| AI_7+/- | Ch8 | GND_PC | GND |
| | AI_0+/- | VCC_OUT | +5 V |

Table 6: ME-AB-5200 signal assignments



***Warning:** Reserved pins must not be connected, otherwise the board may be irreversibly damaged!

C Accessories

We recommend to use high-quality connector cables with single-shielded lines per channel.

For further accessories please refer to the current Meilhaus Electronic catalog and the internet:

www.meilhaus.de/en/pc-boards/accessories/

D Technical Questions

D1 Hotline

Should you have questions or inquiries concerning your Meilhaus device, please contact us:

Meilhaus Electronic GmbH

Repair & Service
Am Sonnenlicht 2
D-82239 Alling

Sales:

Tel.: (08141) 52 71 – 0
Fax: (08141) 52 71 – 129

eMail: sales@meilhaus.de

Support:

Tel.: (08141) 52 71 – 188
Fax: (08141) 52 71 – 169

eMail: support@meilhaus.de

Download-Server and Driver Update:

To download current driver versions for Meilhaus Electronic devices as well as manuals in PDF format, please go to:

www.meilhaus.org/driver

Service Department with RMA Process:

In case you need to return a board for repair purposes, we strongly ask you attach a detailed description of the error as well as information regarding your computer/system and the software used.

Please register online using our RMA process:

www.meilhaus.de/en/infos/service/rma.htm.

E Index

| | | | |
|------------------------------------|--------|--------------------------------|----|
| <hr/> | | <hr/> | |
| A | | I | |
| A/D Section..... | 15 | Important Notes | 5 |
| Accessories | 43 | Input Voltage Ranges | 16 |
| Analog Input | 28 | Interrupt Operation | 30 |
| Appendix | 33 | Introduction | 5 |
| <hr/> | | <hr/> | |
| B | | M | |
| Bit-Pattern Change | 31 | ME-5200 cPCI..... | 14 |
| Bit-Pattern Compare | 32 | ME-5200 PCIe..... | 14 |
| Block diagram..... | 13 | <hr/> | |
| <hr/> | | O | |
| D | | Optional Input Circuitry | 16 |
| Digital Input/Output | 25 | <hr/> | |
| Digital Inputs | 20 | P | |
| Digital Outputs | 20 | Package Contents..... | 6 |
| Digital Trigger Inputs | 19 | Pinout..... | 39 |
| Digital-I/O Section | 20 | Programming | 23 |
| <hr/> | | Pulse Generator | 28 |
| E | | <hr/> | |
| External Interrupt..... | 22 | S | |
| External Trigger | 29 | Single Operation Mode | 25 |
| External Trigger A/D Section | 18 | Software Installation | 11 |
| <hr/> | | Specification..... | 33 |
| F | | Stream Timer | 29 |
| Features..... | 7 | Stream Trigger Sample..... | 29 |
| Frequency Input/Output | 21, 26 | Streaming Mode Operation | 28 |
| Frequency Measurement | 28 | System Requirements | 10 |
| <hr/> | | <hr/> | |
| H | | T | |
| Hardware..... | 13 | Technical Questions | 44 |
| Hotline..... | 44 | Test Program..... | 11 |