

Product Datasheet - Technical Specifications



More information in our Web-Shop at ► www.meilhaus.com and in our download section.

Your contact

**Technical and commercial sales, price information,
quotations, demo/test equipment, consulting:**

Tel.: **+49 - 81 41 - 52 71-0**

FAX: **+49 - 81 41 - 52 71-129**

E-Mail: sales@meilhaus.com

Downloads:

www.meilhaus.com/en/infos/download.htm

Meilhaus Electronic GmbH | Tel. **+49 - 81 41 - 52 71-0**
Am Sonnenlicht 2 | Fax **+49 - 81 41 - 52 71-129**
82239 Alling/Germany | E-Mail sales@meilhaus.com

Mentioned company and product names may be registered trademarks of the respective companies. Prices in Euro plus VAT. Errors and omissions excepted.
© Meilhaus Electronic.

www.meilhaus.de

IEEE-488.2 ANALOG INTERFACE

DESCRIPTION

The Model 4861B is a compact, IEEE-488.2/ GPIB-to-Analog Interface that provides isolated analog signals for controlling analog devices from the GPIB bus. The Model 4861B has four floating analog output channels, four isolated differential analog inputs, digital output drivers and digital inputs. The analog values can be scaled to match the physical values of the input signals or of the controlled parameters. The scale factors and all other user set configuration parameters are saved in flash memory until changed. The 4861B accepts both industry standard SCPI commands and ICS's easy-to-use short form commands. Typical 4861B applications are controlling power supplies, providing analog stimuli or measuring analog signals.

The Model 4861B is the latest version of the 4861 GPIB to Analog Interfaces with many improvements. It is functionally and physically interchangeable with the 4861 or 4861A versions.

Analog Outputs

The 4861B's analog outputs are individually isolated from digital ground and from each other. Each analog output can be individually set to a 0 to + 10, a ± 10 , or to a ± 5 volt output range. Resolution is 1 part in 2^{16} . The analog outputs have separate range, scale factor, offset and limit values that the user can program to match the controlled application.



4861B

Analog Inputs

The 4861B's analog inputs are four floating differential signals that multiplexed into a 16 bit A/D converter as unipolar or bipolar voltages. Each input has an individual 10, 1, or 0.1 volts full scale range setting. The analog inputs are scanned at 200s/sec rate and are internally averaged. The averaged readings can be reported as voltages or individually scaled to correspond to the measured parameter, i.e. volts, amps, watts etc. The analog inputs have 1,000 volts of isolation from digital ground and share power with D/A #4 in standard units. The -I option fully isolates the A/D from the D/A Ch#4.

Digital I/O

The Model 4861B provides four relay driver outputs and eight digital inputs. The digital outputs are open-collector darlington drivers that sink up to 300 mA. Output #4 can be used as a Fault Output signal to display ESR Register errors. The digital input lines have pullup resistors and accept TTL/CMOS levels or contact closure inputs. The 4861B can monitor the digital inputs and use the 488.2 status reporting structure to generate an SRQ (Service Request) when a change occurs.

- Four 16-bit analog outputs with 1,000 Vdc isolation. *Controls analog devices without ground loops.*
- Four isolated differential analog inputs with programmable ranges. *Programmable inputs for reading voltage sources, current shunts, sensors etc.*
- Four high current drivers to operate external relays. *Digital control of external devices*
- Digital inputs read or monitor discrete signals. *Generates SRQ on selected signal changes.*
- User settable scale factors for analog signals. *Matches 4861B commands and responses to system values.*
- OEM board versions available with GPIB and RS-232 and RS-485 serial interfaces. *Greater versatility.*
- Includes example control, configuration and LabVIEW programs. *Complete software support.*

CE Approved

RoHS Compliant

ICS ELECTRONICS
division of Systems West Inc.

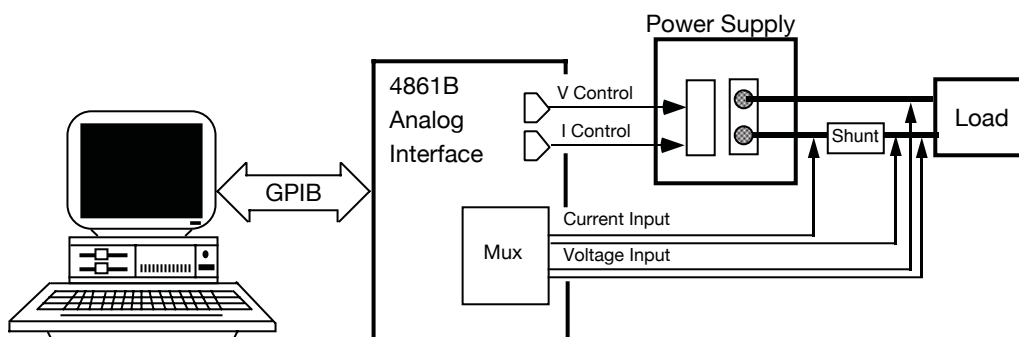

Figure 1 Using the 4861B to control a power supply and measure its outputs

Scaling

Programmable scale factors and offsets let the user program the 4861B's outputs and read back measured values in system values. The 4861B's output voltage follows the equation

$$V_{out} = (M * V_{cmd}) + B.$$

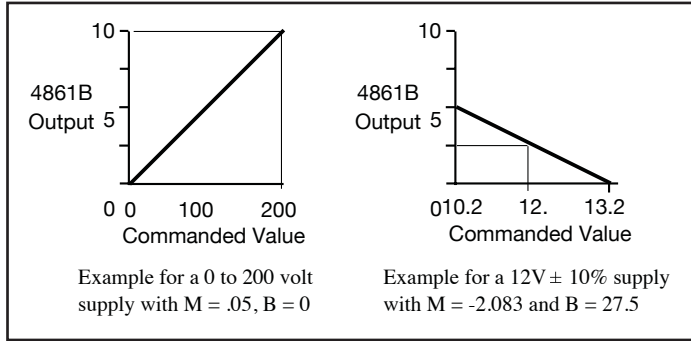

Figure 2 Output Voltages for different Scale Factors and Offsets

Figure 2 shows two examples of output voltage scaling by changing the slope (M) and offset (B) values. Similarly, measured voltages may be scaled to convert the voltage readings to match the measured parameter. (i.e. 0-10 V becomes 0-300 °C). The scaling values may be saved in the 4861B's flash memory.

4861B Improvements

The 4861B includes several improvements over prior 4861 models. D/A and A/D isolation has been increased from 750 to 1,000 volts. D/A channel #4 has always provided a small amount of power to the A/D section so they share a common ground. The 4861B can be ordered with a fully isolated D/A channel #4 by specifying the 'I' option. The A/D resolution has been increased to 16 bits which results in increased accuracy for the measured signals. The serial versions now support standard terminated command strings, addressed command strings and a secure packet protocol for RS-485 network operation.

IEEE-488.2 and SCPI Compatibility

The Model 4861B complies with the IEEE-488.2 STD and responds to all of the required 488.2 common commands. The 4861B uses SCPI (Standard Commands for Programmable Instruments) commands for ease of programming and also responds to ICS's short form commands for easy control from a computer keyboard.

The 4861B's more common commands are listed in the SCPI Command Tree shown in Table 2. The SYSTem command group sets the GPIB address and enables the external address for the board version. The STATus group reads the digital inputs through the Questionable Status Register. Changes in the digital inputs can be used to generate a Service Request (SRQ). The INSTRument command group sets the channel address for the MEASure and SOURce groups. The MEASure and SOURce command groups control the analog input and output functions. The OUTPut group controls the four output lines. The CALibration commands let the OEM configure the unit as their own product.

TABLE 2 SCPI COMMAND TREE

SCPI Commands	General	Short Form Cmds
SYSTem		
:COMM		
:SERial		
:EXTernal	1 (On) 0 (Off) [0]	
:BAUD	<numeric>[9600]	
:PARity	EVEN ODD [NONE]	
:BITS	7 [8]	
:SBITs	[1] 2	
:NETwork	Off ADDRess PACKet [Off]	
:ADDRess	<numeric> [4]	
:GPIB		
:ADDRess	<numeric> [4]	
:EXTernal	1 (On) 0 (Off) [0]	
:UPDAte		
:ERRor?		
:VERsion?		
STATus		
:OPERation	WTG Status	
[:EVENT]?		
:CONDition?		
:ENABle	<numeric>	
:QUESTionable	Digital Inputs	
[:EVENT]?		
:CONDition?		
:ENABle	<numeric>	
:PTRansistion	<numeric>	
:NTRansistion	<numeric>	
INSTRument		
:NSElect	Channel Select	C
SOURce Analog Outputs		
:VOLTage		
[:LEVel]		
[:IMMEDIATE]		
[:AMPLitude]	<numeric>	D
:TRIGgered		
[:AMPLitude]	<numeric>	T
:LIMit		
[:AMPLitude]	<numeric>	L
:OFFset		
[:AMPLitude]	<numeric>	B
:POLarity	<numeric>	DB
:SLOPe		
[:AMPLitude]	<numeric>	M
:DIGital Digital Outputs		
:DATA		
[:VALue]	0-15	DD
:POLarity	0-15	DP
OUTPut		
:STATe <boolean>	OC	
:POLarity	1 0	OP
INITate Trigger Enable		
[:IMMEDIATE]		TI
:CONTinuous	<boolean>	TC
MEASure Analog Inputs		
:VOLTage?		
[:DC]	channel list	A?n
:RANGe	10, 1, 0.1	AR
:POLarity	1 2	AB
:AVERage	<numeric>	AF
CALibrate		
:IDN	string	
:DATE	mm/dd/yyyy	
:FAULT	1 (On) 0 (Off) [0]	
:LOCK	1 (On) 0 (Off) [0]	

OEM Board Version

Board versions of the 4861B are available for OEM applications or installations in test chassis. Board versions are designed to be mounted in the host's chassis and are powered from the host's power supply. On OEM boards, the GPIB, LED and Serial headers are mounted vertically for quick cable connections and to minimize the board footprint. (See Figure 3).

RS-232/RS-485 Interfaces

OEM boards include RS-232 and RS-485 serial interfaces. The serial interfaces provide all of the functionality of the GPIB interface but allow control of the 4861B from a PC's COM port or from an RS-485 network. The RS-232 port is a 3-wire interface with Tx and Rx signals. The RS-485 port is a 2-wire, half-duplex interface with a pullup-pull-down resistor terminating network that biases the lines when idle. The 4861B's firmware supports up to sixteen 4861Bs on a single RS-485 network.

GPIB Header and Address Switch

OEM boards have a 26 pin header for remoting the GPIB and address switch signals to the rear panel. Standard 4861Bs save their GPIB address in flash memory and use a SCPI command to change it. OEM boards have additional input lines to read an external address switch when a rear panel mounted switch is desired. The GPIB header mates with a flat ribbon cable from ICS's GPIB Connector/Address switch assemblies. These compact, business card size assemblies are a convenient way to mount a GPIB Connector and an address switch on the rear panel.

LED Header

An 8 pin header on the OEM boards allows easy extension of the LEDs to the user's front panel.

OEM Customizing

The user's IDN message, scale factors and other user set parameters are saved in the 4861B's flash memory. This makes the completed assembly respond as the OEM's product. A lock function hides these variables from the end user and prevents accidental changes to the setup.

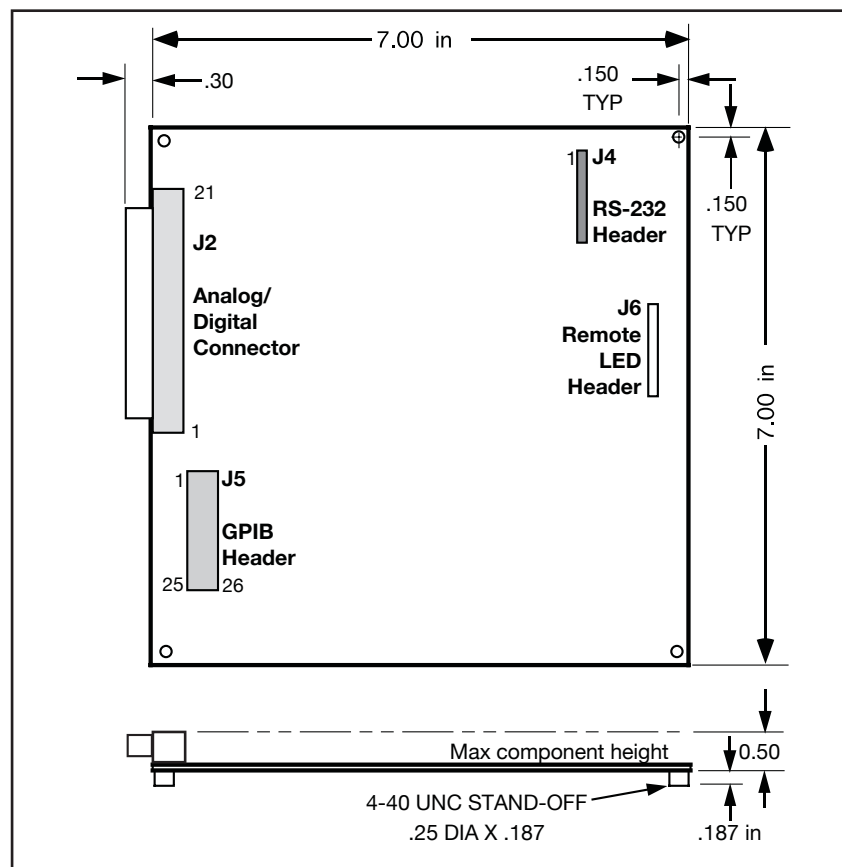

Figure 3 4861B OEM Board Dimensions

TABLE 3 ANALOG-DIGITAL SIGNALS

Signal	Pin	Signal	Pin
Vcc	1		
Digital Out V Com	2		
Digital Out 1	6	Digital Out 3 4	
Digital Out 2	5	Digital Out 4 3	
Digital Return	7	Digital Return	28
Digital Ground	48	Digital Input 3	22
Digital Input 6	44	Digital Input 2	47
Digital Input 5	43	Digital Input 1	46
Digital Input 4	45	Digital Input 7	23
		Digital Input 8	24
Analog Input 1+	11	Analog Input 1-	32
Analog Input 2+	10	Analog Input 2-	31
Analog Input 3+	9	Analog Input 3-	30
Analog Input 4+	8	Analog Input 4-	29
Analog Out 1+	42		
Analog Out 1-	21		
Chassis Gnd	20		
Analog Out 2+	40		
Analog Out 2-	19		
Chassis Gnd	18		
Analog Out 3+	36		
Analog Out 3-	15		
Chassis Gnd	14		
Analog Out 4+	34		
Analog Out 4-	13		
Chassis Gnd	12		
+ 12 Vdc Input*	17	+12 Vdc Return	16
+ 12 Vdc Input*	39	+12 Vdc Return	38
+ 12 Vdc Input*	60	+12 Vdc Return	59
Chassis Ground	53	Chassis Ground	33

4861B SPECIFICATIONS

IEEE 488 Bus Interface

IEEE 488 Bus interface meets IEEE STD 488.1-1987 and has the following capabilities.

SH1, AH1, T6, L4, SR1, PP0, DC1, RLI, DT1, C0 and E1/E2 drivers.

Bus drivers incorporate power-up/down protection to prevent sending invalid data to the bus.

GPIB Address Capability: 0-30

SRQ Generation

SRQs are generated if the event and summary bits are enabled and the event or signal change occurs. Events include the 488.2 Event Status Bits and the monitored digital inputs.

488.2 Common Commands

*CLS, *ESE, *ESE?, *ESR?, *IDN?, *OPC, *OPC?, *PSC, *PSC? *RCL, *RST, *SAV, *SRE, *SRE?, *TRG, *TST, and *WAI.

Optional Serial Interface

RS-232/RS-485 asynchronous interfaces on an internal 10 pin header. Data rates up to 115.2 Kbaud.

RS-232 interface includes TX, RX, and ground signals.

RS-485 interface includes TX/RX+ and RX/RX- signals with a 220 ohm load resistor and 1 K Ω pullup/pulldown resistors.

Supported Protocols

Terminated command strings
Addressed command strings
Packets (RS-485 only)

Certifications and Approvals

Meets Part 15, Class A of FCC Docket 20780 and EEC Standards EN 55022 and 50082-1.

Analog Outputs

All parameters are specified at 25 °C. Range is jumper selected.

Channels 4
Ranges 0 to +10, ± 10 , ± 5 Vdc
Output current ± 5 mA typ.
Isolation 1,000 Vdc,

Zero
Unipolar 0
Bipolar Mid range
Resolution 1 part in 65,535
Non-linearity ± 4 bits
Zero error ± 8 bits (Unipolar)
 ± 4 bits (Bipolar)
End Point Error ± 30 mV

Temp Drift
Gain ± 20 typ.PPM/° C
Offset ± 2 PPM FSR/° C
Output ripple 30 mV P-P, 500 kHz
Update time 8 msec from command terminator.

Analog Inputs

All parameters are specified at 25 °C. Polarity is jumper selected.

Channels 4
Range 0.1, 1 or 10 volts
Polarity Unipolar or bipolar
Max. Input ± 15 V max.
Input Impedance 1 Megohm
Isolation 1,000 volts, shares D/A #4 ground in standard unit.
-I option provides separate grounds.

Resolution 1 part in 65,535
Non-linearity ± 1 bit on 10 V range

FS Error
Ranges 10V 1V 100mV
Unipolar 5mV 1mV 0.5mV
Bipolar 10mV 2mV 1mV
Temp Drift ± 17 PPM/°C

Zero Drift
Bipolar ± 0.4 PPM/°C
Unipolar ± 2 PPM/°C
End Point 2 x FS error
Conversion Time 4 microseconds
Digital Filter 1-100 readings
Read time 8.5 msec max.

Digital Inputs

Inputs 8 lines
Logic Levels
Low 0 ± 0.5 Vdc
High > 2.4 Vdc
Pullup Resistors 33 kohm to +5 Vdc.
Query time 10 msec to GPIB response

Digital Outputs

Outputs 4 darlington driver outputs with diodes to V common input
Logic Levels
On < 0.7 V @ 20 mA
 < 1.2 V @ 200 mA
Off V Com - 0.7 V
V Common 48 Vdc maximum
Output delay 3 msec from command terminator

Physical

Size W x H x D (Std Units)
185.2 x 185.2 x 38.6 mm
(7.29 x 7.29 x 1.52 inches)

Size W x H x D (OEM Boards)
177.8 x 29.5 x 177.8 mm
(7.0 x 1.16 x 7.0 inches)

Weight 3 lbs (1.4 kg)

Connectors

Analog/Digital 62-pin D shell (All)
IEEE bus 24-pin GPIB (Module)
26-pin header (OEM Bd)
RS-232 DB-25S (Module)
10-pin header (OEM Bd)
LEDs 8-pin header (OEM Bd)

Temperature

Operation -10° C to $+55^\circ$ C
Storage -40° C to $+70^\circ$ C

Power $+12 \pm 0.3$ Vdc, 7 VA

Included Accessories

Instruction Manual
Support CD with utility and example programs
Mating 62-pin connector and hood
CE/UL/CSA/VDE approved 100/240 VAC power adapter with with US/Japan, European, UK and Australia/China plugs.
Operates over 80/240 Vac, 60 Hz.

ORDERING INFORMATION

	Part Number
GPIB<-> Analog Interface with A/D, 4 channels D/A and universal 100/240 VAC adapter	4861B-24
GPIB<-> Analog Interface with fully isolated A/D, 4 channels D/A, and universal 100/240 VAC adapter	4861B-24-I
OEM 4861B Board with A/D, 4 channels D/A with GPIB and Serial I/O	114578-24