

## Product Datasheet - Technical Specifications



More information in our Web-Shop at ► [www.meilhaus.com](http://www.meilhaus.com) and in our download section.

### Your contact

**Technical and commercial sales, price information,  
quotations, demo/test equipment, consulting:**

Tel.: **+49 - 81 41 - 52 71-0**

FAX: **+49 - 81 41 - 52 71-129**

E-Mail: [sales@meilhaus.com](mailto:sales@meilhaus.com)

Downloads:

[www.meilhaus.com/en/infos/download.htm](http://www.meilhaus.com/en/infos/download.htm)

**Meilhaus Electronic GmbH** | Tel. **+49 - 81 41 - 52 71-0**  
Am Sonnenlicht 2 | Fax **+49 - 81 41 - 52 71-129**  
82239 Alling/Germany | E-Mail [sales@meilhaus.com](mailto:sales@meilhaus.com)

Mentioned company and product names may be registered trademarks of the respective companies. Prices in Euro plus VAT. Errors and omissions excepted.  
© Meilhaus Electronic.

[www.meilhaus.de](http://www.meilhaus.de)



# SCM5B42

## 2-Wire Transmitter Interface Modules

### Description

Each SCM5B42 2-wire transmitter interface module provides a single channel which accepts a 4 to 20mA process current input and provides a standard +1 to +5V or +2 to +10V output signal (Figure 1). An isolated +20VDC regulated power supply is provided to power the current transmitter. This allows a 2-wire loop powered transmitter to be directly connected to the SCM5B42 without requiring an external power supply. The regulated supply will provide a nominal +20VDC at a loop current of 4mA to 20mA.

The SCM5B42 will provide a 1500V isolation barrier for non-isolated 2-wire field transmitters. It can also be used when additional isolation is required between an isolated 2-wire transmitter and the input stage of the control room computer.

The voltage output is logic switch controlled, which allows these modules to share a common analog bus without the requirement of external multiplexers.

The SCM5B modules are designed with a completely isolated computer side circuit which can be floated to ±50V from Power Common, pin 16. This complete isolation means that no connection is required between I/O Common and Power Common for proper operation of the output switch. If desired, the output switch can be turned on continuously by simply connecting pin 22, the Read-Enable pin, to I/O Common, pin 19.

A precision 20Ω current conversion resistor is supplied with the module. Sockets are provided on the SCMPB01/02/03/04/05/06/07 backpanels to allow installation of this resistor. Extra resistors are available under part number SCMXR1. All field inputs are fully protected from accidental connection of power-line voltages up to 240VAC. The module has a 3dB bandwidth of 100Hz. Signal filtering is accomplished with a six-pole filter, with two poles on the field side of the isolation barrier, and the other four on the computer side.

### Features

- Isolated +20VDC Current Loop Supply
- Provides Isolation for Non-Isolated 2-Wire Transmitters
- High-Level Voltage Output +1V to +5V or +2V to +10V
- 1500Vrms Transformer Isolation
- ANSI/IEEE C37.90.1 Transient Protection
- Input Protected to 240VAC Continuous
- 100dB CMR
- 100Hz Signal Bandwidth
- ±0.03% Accuracy
- ±0.005% Linearity
- CSA C/US Certified
- CE and ATEX Compliant
- Mix and Match SCM5B Types on Backpanel

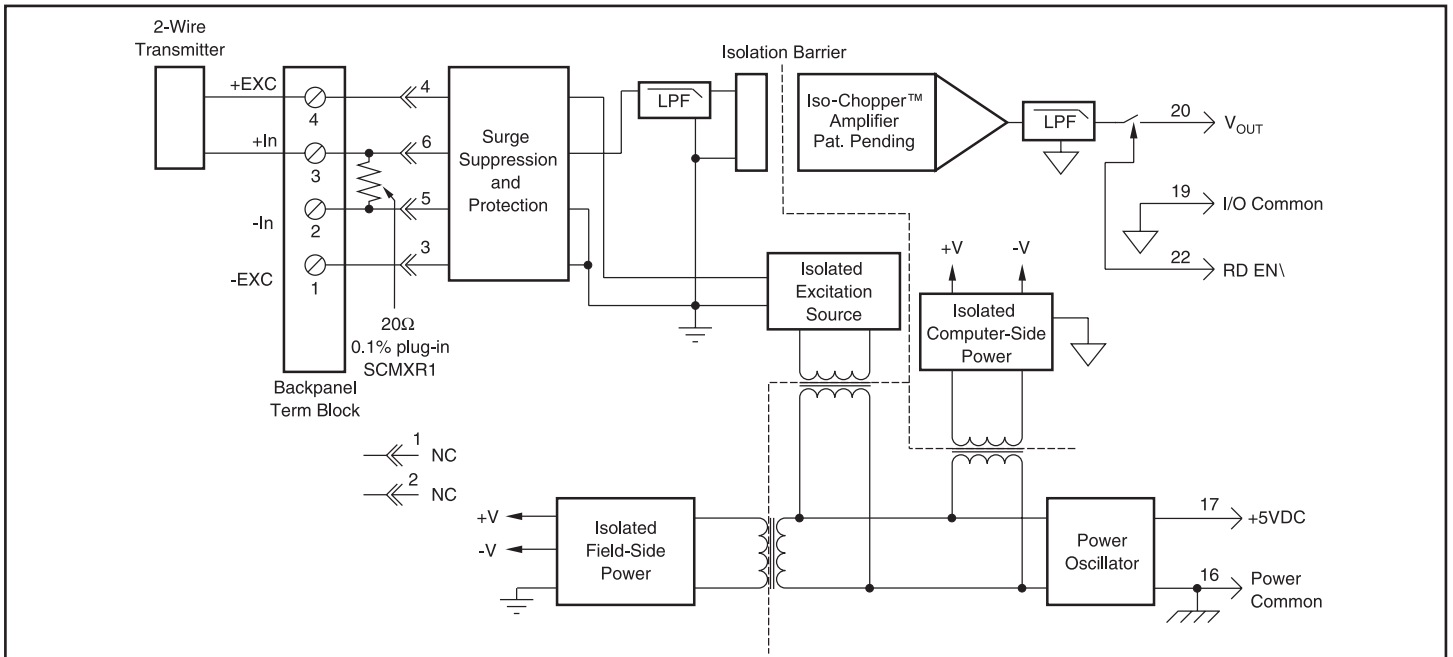

Figure 1: SCM5B42 Block Diagram

**Specifications** Typical\* at  $T_A = +25^\circ\text{C}$  and +5VDC power

Module	SCM5B42
Input Range	4mA to 20mA
Input Resistor	
Value	20.00 $\Omega$
Accuracy	$\pm 0.1\%$
Stability	$\pm 10\text{ppm}/^\circ\text{C}$
Loop Supply Voltage	Nominal 20V at 4mA to 20mA
Isolated Excitation Protection	
Continuous	240Vrms max
Transient	ANSI/IEEE C37.90.1
Input Protection	
Continuous	240Vrms max
Transient	ANSI/IEEE C37.90.1
CMV, Input to Output	
Continuous	1500Vrms max
Transient	ANSI/IEEE C37.90.1
CMR (50 or 60Hz)	100dB
NMR (-3dB at 100Hz)	120dB per Decade above 100Hz
Accuracy <sup>(1)</sup>	$\pm 0.03\%$ Span
Linearity	$\pm 0.005\%$ Span
Stability	
Input Offset	$\pm 1\mu\text{V}/^\circ\text{C}$
Output Offset	$\pm 40\mu\text{V}/^\circ\text{C}$
Gain	$\pm 25\text{ppm}/^\circ\text{C}$ of Reading
Noise	
Input, 0.1 to 10Hz	10nArms
Output, 100kHz	500 $\mu\text{V}$ rms
Bandwidth, -3dB	100Hz
Response Time, 90% Span	4mS
Output Range	+1V to +5V or +2V to +10V
Output Resistance	50 $\Omega$
Output Protection	Continuous Short to Ground
Output Selection Time (to $\pm 1\text{mV}$ of $V_{\text{OUT}}$ )	6 $\mu\text{s}$ at $C_{\text{load}} = 0$ to 2000pF
Output Current Limit	+8mA
Output Enable Control	
Max Logic "0"	+0.8V
Min Logic "1"	+2.4V
Max Logic "1"	+36V
Input Current "0,1"	0.5 $\mu\text{A}$
Power Supply Voltage	+5VDC $\pm 5\%$
Power Supply Current	180mA at Transmitter Load of 20mA 100mA at Transmitter Load of 4mA
Power Supply Sensitivity	$\pm 10\mu\text{V}/\%$ RTI <sup>(2)</sup>
Mechanical Dimensions (h)(w)(d)	2.28" x 2.26" x 0.60" (58mm x 57mm x 15mm)
Environmental	
Operating Temp. Range	-40 $^\circ\text{C}$ to +85 $^\circ\text{C}$
Storage Temp. Range	-40 $^\circ\text{C}$ to +85 $^\circ\text{C}$
Relative Humidity	0 to 95% Noncondensing
Emissions EN61000-6-4	ISM, Group 1
Radiated, Conducted	Class A
Immunity EN61000-6-2	ISM, Group 1
RF	Performance A $\pm 0.5\%$ Span Error
ESD,EFT	Performance B

## NOTES:

\*Contact factory or your local Dataforth sales office for maximum values.

(1) Includes linearity, hysteresis and repeatability. Does not include SCMXR1 accuracy.

(2) RTI = Referenced to input.

**Ordering Information**

Model	Input Range	Output Range
SCM5B42-01	4mA to 20mA	+1V to +5V
SCM5B42-02	4mA to 20mA	+2V to +10V