

## Product Datasheet - Technical Specifications



More information in our Web-Shop at ► [www.meilhaus.com](http://www.meilhaus.com) and in our download section.

### Your contact

**Technical and commercial sales, price information,  
quotations, demo/test equipment, consulting:**

Tel.: **+49 - 81 41 - 52 71-0**

FAX: **+49 - 81 41 - 52 71-129**

E-Mail: [sales@meilhaus.com](mailto:sales@meilhaus.com)

Downloads:

[www.meilhaus.com/en/infos/download.htm](http://www.meilhaus.com/en/infos/download.htm)

**Meilhaus Electronic GmbH** | Tel. **+49 - 81 41 - 52 71-0**  
Am Sonnenlicht 2 | Fax **+49 - 81 41 - 52 71-129**  
82239 Alling/Germany | E-Mail [sales@meilhaus.com](mailto:sales@meilhaus.com)

Mentioned company and product names may be registered trademarks of the respective companies. Prices in Euro plus VAT. Errors and omissions excepted.  
© Meilhaus Electronic.

[www.meilhaus.de](http://www.meilhaus.de)

# SCM5B48

## Accelerometer Input Module



### Description

The SCM5B48 provides excitation to piezoelectric sensors with built-in microelectronic amplifiers, commonly known as ICP®\* or IEPE\* or LIVM\* sensors. The module provides a constant current excitation to the sensor, then isolates, filters, and amplifies the sensor output, yielding a high-level analog voltage output (Figure 1). The excitation current, signal gain, and filter high-pass and low-pass cutoff frequencies are field-configurable through a set of slide switches.

Six poles of signal filtering in the SCM5B48 module result in greater than 100dB of normal-mode rejection for signal frequencies above the cutoff frequency. One pole of filtering is on the field side of the isolation barrier for anti-aliasing purposes and the remaining five-pole programmable Bessel filter is located on the system side. High-pass filtering is achieved through a second order passive filter, located on the field side. If desired, the output switch can be turned on continuously by simply connecting pin 22, the Read-Enable pin, to I/O Common, pin 19.

The SCM5B48 offers the option of setting the constant current source for sensor excitation to common values of 4mA or 9mA with a compliance voltage of 24VDC. Programmable gains of 1, 10 and 100 are selectable and the module offers a ±10V output. The required supply level is +5VDC, ±5%.

To ensure protection of expensive data acquisition equipment, the SCM5B48 module signal inputs and sensor excitation outputs are protected against accidental connection of voltages up to 240Vrms.

\*ICP is a registered trademark of PCB Group Inc.

\*IEPE is Integrated Electronic Piezo-Electric

\*LIVM is Low Impedance Voltage Mode

### Features

- Interfaces to ICP®\* or IEPE\* or LIVM\* Sensors
- ±5V or ±10V Output Range
- 1500Vrms Transformer Isolation
- ANSI/IEEE C37.90.1 Transient Protection
- Input Protection to 240Vrms Continuous
- 1, 10, and 100 Programmable Gain
- 2.5, 5, 10, and 20kHz Programmable LP Filter
- 0.2 and 10Hz Programmable HP Filter
- 4mA or 9mA Programmable Current Excitation
- 100dB CMR
- ±0.2% Accuracy
- ±0.01% Linearity
- Low Drift with Ambient Temperature
- -40°C to +85°C Operating Temperature Range
- CSA C/US Certified
- CE Compliant
- ATEX Compliance Pending
- Mix and Match SCM5B Types on Backpanel

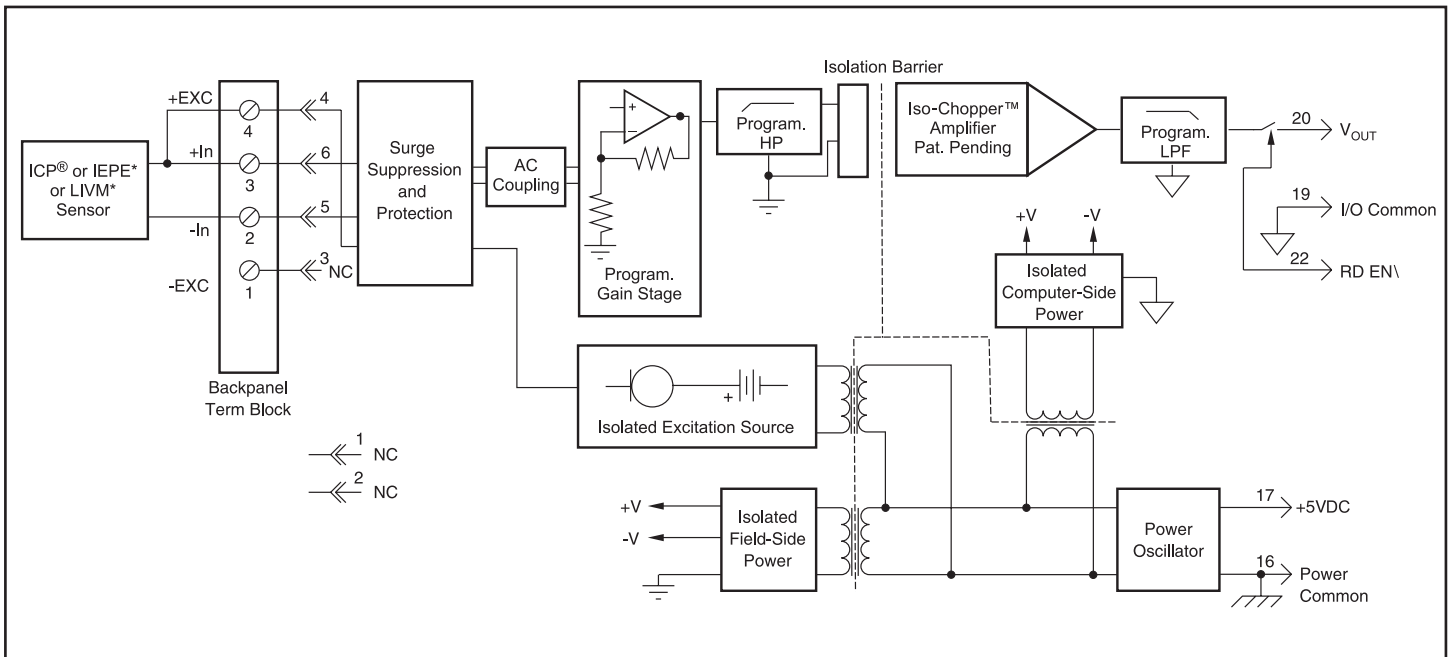

Figure 1: SCM5B48 Block Diagram

**Specifications** Typical\* at T<sub>A</sub> = +25°C and +5VDC power

Module	SCM5B48
Input Type	Accelerometer
Range <sup>(1)</sup>	±10V
Protection	
Continuous	240Vrms max
Transient	ANSI/IEEE C37.90.1
Excitation	
Constant Current <sup>(2)</sup>	4mA or 9mA, ±10%
Compliance Voltage	24V ±10%
Protection	
Continuous	240Vrms max
Transient	ANSI/IEEE C37.90.1
Output Range	See Ordering Information
Resistance	50Ω
Protection	Continuous Short to Ground
Gain	
Programmable <sup>(2)</sup>	1, 10, 100
CMR (50/60Hz)	100dB
Accuracy <sup>(3)</sup>	±0.2% Span
Linearity	±0.01% Span
Stability	
Offset	±25ppm/°C
Gain	±100ppm/°C
Output Noise, Gain≠ , BW=20kHz	200µVrms
Low Pass Filter	
Type	Bessel
Programmable <sup>(2)</sup>	2.5kHz, 5kHz, 10kHz, 20kHz
High Pass Filter	
Programmable <sup>(2)</sup>	DC, 0.2Hz, 10Hz
CMV (Input to Output)	
Continuous	1500Vrms max
Transient	ANSI/IEEE C37.90.1
NMR	100db per Decade above cutoff frequency
Power Supply Voltage	+5VDC ±5%
Power Supply Current	110mA typical (9mA excitation) 70mA typical (4mA excitation)
Power Supply Sensitivity	±600µV/% RTI <sup>(4)</sup>
Mechanical Dimensions (h)(w)(d)	2.28" x 2.26" x 0.6" (58mm x 57mm x 15mm)
Environmental	
Operating Temperature Range	-40°C to +85°C
Storage Temperature Range	-40°C to +85°C

**Ordering Information**

Model	Input Range <sup>(1)</sup>	Output Range	Bandwidth
SCM5B48-01	-10V to +10V	-10V to +10V	2.5kHz to 20kHz <sup>(2)</sup>
SCM5B48-02	-10V to +10V	-5V to +5V	2.5kHz to 20kHz <sup>(2)</sup>

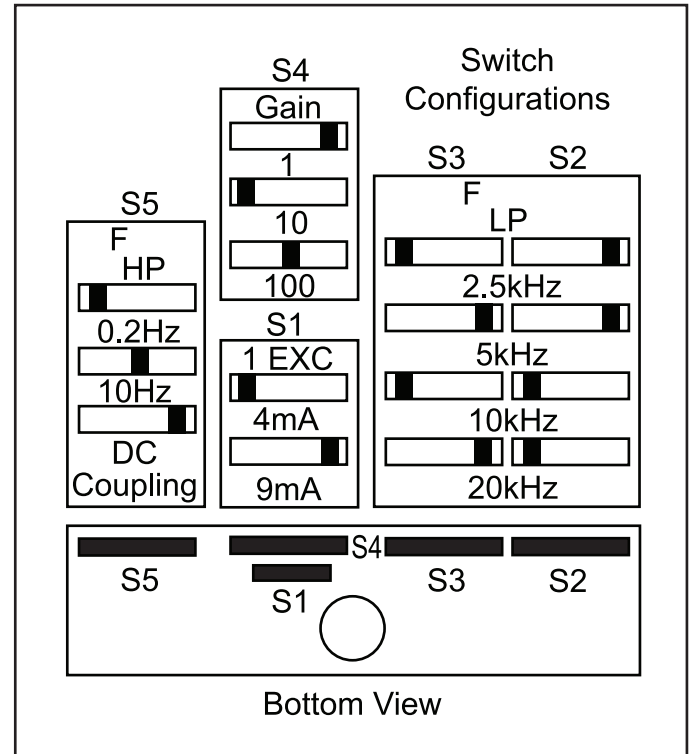

Figure 2: SCM5B48 Side Label

NOTES:

- \*Contact factory or your local Dataforth sales office for maximum values.
- (1) AC peak for AC coupling. For DC coupling input range (AC + DC): 0 to +10V.
- (2) Programmable using slide switches on the bottom of the module.
- (3) Includes linearity, repeatability and hysteresis.
- (4) RTI = Referenced to input.