

Product Datasheet - Technical Specifications



More information in our Web-Shop at ► www.meilhaus.com

Your contact

Technical and commercial sales, price information,
quotations, demo/test equipment, consulting:

Tel.: **+49 - (0)81 41 - 52 71-0**

FAX: **+49 - (0)81 41 - 52 71-129**

E-Mail: sales@meilhaus.com

Meilhaus Electronic GmbH
Am Sonnenlicht 2
82239 Alling/Germany

Tel. **+49 - (0)81 41 - 52 71-0**
Fax **+49 - (0)81 41 - 52 71-129**
E-Mail sales@meilhaus.com

Mentioned company and product names may be registered trademarks of the respective companies. Errors and omissions excepted. © Meilhaus Electronic.

V 1.3

TBLC08



TEKBOX
DIGITAL SOLUTIONS

TBLC08 50mH AC-LISN

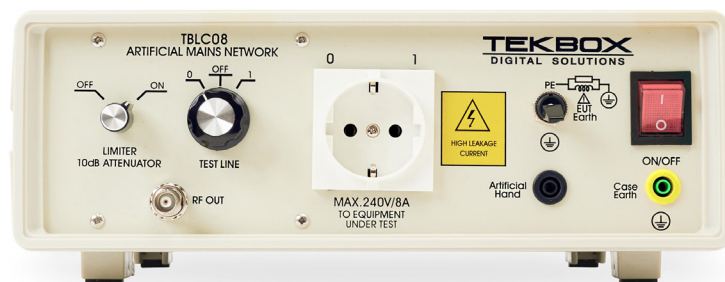

The TBLC08 is a Line Impedance Stabilization Network for the measurement of line-conducted interference within the range of 9kHz to 30MHz, according to the CISPR16 standard. The device is designed for testing single phase, AC-powered equipment with supply voltages up to maximum 260V. Conducted noise can be measured on the phase and on the neutral conductor. The TBLC08 is equipped with a switchable limiter/attenuator and an artificial hand connection. The device is available with country-specific DUT connectors.

V_{1.3}

TBLC08



TBLC08 with Australian AS/NZS 3112 socket variant

FEATURES

- Frequency range: 9 kHz to 30 MHz
- Impedance: $50 \Omega \parallel (50 \mu\text{H} + 5 \Omega)$
- Artificial hand: $220 \text{ pF} + 511 \Omega$
- Switchable PE: $50 \Omega \parallel 50 \mu\text{H}$
- Limiter / attenuator: 150 kHz to 30 MHz; 10 dB
- Air core inductors
- Line voltage: max. 240V / 50 – 60 Hz, CAT II
- Max. current: 8A @ 23°C
- DUT socket: country specific
- Measurement connector: 50Ω BNC
- Power connector: IEC 60320 C13
- Operating Temperature Range:
 - +5°C ... + 40°C; 5% to 80% RH
- Safety: Safety Class I, IEC 1010-01

APPLICATION

- EMC pre-compliance testing of conducted noise

V1.3

TBLC08

CONTENTS

SAFETY	3	2.5 FRONT PANEL	6
1 INTRODUCTION	3	2.6 REAR PANEL	7
1.1 PRE-COMPLIANCE TESTING OF CONDUCTED EMISSIONS	3	2.7 IMPEDANCE	8
1.2 LINE IMPEDANCE STABILIZATION NETWORKS	4	2.8 FREQUENCY RESPONSE, S21 FROM DUT PORT TO RF PORT	8
1.3 RF OUTPUT	4	2.9 CALIBRATION DATA ACCORDING TO CISPR 16 -1-2 ANNEX A8	10
1.4 INFORMATIVE SCHEMATIC	4	2.10 PROTECTION	11
1.5 LABORATORY SET UP	5	2.11 ARTIFICIAL HAND	12
1.6 GROUND PLANE	5		
2 TBLC08 SPECIFICATIONS	5	3 OPERATION CHECKLIST	12
2.1 CONFORMITY	5	4 ORDERING INFORMATION	12
2.2 SAFETY	5	5 HISTORY	13
2.3 SPECIFICATIONS	5		
2.4 SUPPLY VOLTAGE	6		

TABLES

Table 1 – Frequency response 9kHz to 300MHz, DUT connector Phase/Neutral to RF connector	9
Table 2 – TBLC08 LISN calibration data	10
Table 3 – Ordering Information	12
Table 4 – History	13

PICTURES

Figure 1 – Basic AC LISN set up: impedance levels	4
Figure 2 – AC LISN, informative schematic	4
Figure 3 – Conducted noise pre-compliance measurement setup	5
Figure 4 – Front panel layout	6
Figure 5 – DUT connector, pin assignment with reference to the rear power connector *)	6
Figure 6 – Rear panel layout	7
Figure 7 – Mains connector, pin assignment *)	7
Figure 8 – impedance vs. frequency at DUT terminals	8
Figure 9 – Frequency response 9kHz to 300MHz, DUT connector Phase/Neutral to RF connector	8
Figure 10 – Calibration set up according to CISPR 16-1-2 Annex A.8.	10
Figure 11 – Example from CISPR 16, portable electric saw with artificial hand	12

SAFETY

Operating an AC LISN involves dealing with potentially lethal voltages and high ground leakage currents.



Read this manual carefully and be sure to understand the operation of an AC LISN. Make sure that the conducted noise pre – compliance test equipment is set up correctly and that the necessary earth connections are reliably bonded to avoid the risk of lethal electric shocks.

Make sure to understand the operation of the attenuator / limiter to avoid any damage to your test receiver or spectrum analyzer.

Do not carry out any modifications or manipulations of the TBLC08. User maintenance of the TBLC08 is strictly limited to the replacement of the fuses.

1. INTRODUCTION

1.1. PRE-COMPLIANCE TESTING OF CONDUCTED EMISSIONS

Full compliance measurement of AC mains supplied products requires a high end set up consisting of an anechoic or screened chamber, a measurement receiver that complies with the requirements of CISPR 16, a 50 μ H LISN and a suitable table for the measurement setup. Great effort and cost ensures optimum accuracy and repeatability.

Pre-compliance measurements target to give an approximation of the EMC performance of the Device Under Test at a fraction of the cost of full compliance testing. The measurement receiver can be replaced by a spectrum analyzer with suitable sensitivity, bandwidth and detectors. The advent of affordable spectrum analyzers with EMI detectors such as the DSA815 from Rigol or similar products made EMC pre-compliance testing affordable for any company which develops electronic products. Together with test accessories from Tekbox, EMC pre-compliance setups cost hardly more than a standard oscilloscope a few years ago.

Eliminate uncertainty before going to the test house for compliance testing. There is hardly anything that can give you a return on invest as quickly as EMC pre compliance test equipment.

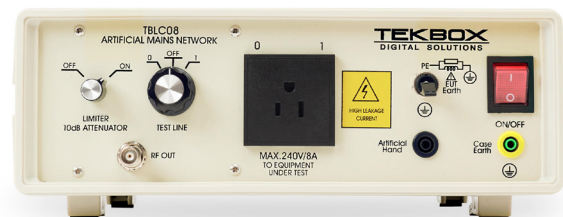
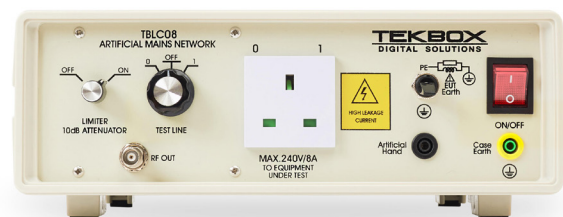

1.2. LINE IMPEDANCE STABILIZATION NETWORKS

Any LISN (line impedance stabilization network) is basically a kind of filter. A LISN is always inserted between the supply input terminals of the DUT (Device Under Test) and the supply which is used to power the DUT. It presents a defined impedance for the noise which is produced by the DUT and emitted via the supply cables of the Device Under Test. The impedance seen by the RF emissions is 50 Ohms || 50µH which results in 50 Ohms for the most part of the specified frequency range. Only at the

lower edge of its bandwidth, the impedance decreases. This impedance curve is specified in the corresponding test standards. Having a defined impedance for the emissions at the DUT terminals eliminates any influence of the power source impedance. Consequently, the measured amplitudes of the noise spectrum become independent of the power source characteristics:

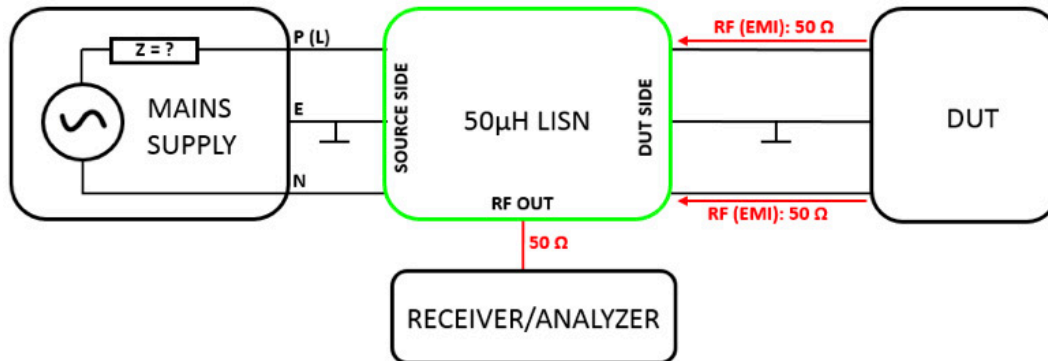

Figure 1 – Basic AC LISN set up: impedance levels.

Furthermore, the AC LISN attenuates noise originating from the incoming mains supply towards the Receiver/Analyzer and DUT.

1.3. RF OUTPUT

The RF output section is AC coupled to either the phase or neutral line. The path can be selected by a rotary switch at the front panel. The RF section also contains an attenuator/limiter and a high pass filter.

Purpose of the high pass filter is the attenuation of harmonics originating from the mains supply. The attenuator/limiter protects the measurement receiver / spectrum analyzer input from high amplitude pulse transients. The phase and neutral line can be the source of such transients, in particular those produced on turning off the DUT. Consequently it is highly advised to disconnect the spectrum analyzer via cable or line selector switch in OFF position while turning on/off the DUT. Use external attenuators and the built in attenuator/limiter to check the lower frequency range for spurious with high power until you are sure, that the spurious levels are not exceeding the maximum input level

range of the spectrum analyzer. For pre-compliance measurements the Attenuator/Limiter should be turned off then, as the limiter is a non-linear component which can create intermodulation and falsify the measurement result. Use external attenuators instead, if necessary

WARNING: Ensure that the spectrum analyzer RF input is disconnected when powering on or powering off the DUT. Leave the attenuator always turned on, if the DUT switches inductive loads during operation or in case of any uncertainty concerning the DUT characteristics. After ensuring that the spectrum analyzer is not over loaded, turn the Attenuator/Limiter Off or use external attenuators to avoid potential intermodulation products creating a measurement error.

1.4. INFORMATIVE SCHEMATIC

The picture below shows the basic topology and the values of the main components of an AC LISN which is used to perform conducted emissions testing. It originates from VDE conducted emissions testing and is also used for CISPR15 testing of lighting products. It includes additional capacitors and inductors for filtering and has an operating frequency range of 9kHz to 30MHz.

NOTE the high capacitor values which cause considerable blind current at 50Hz/60Hz line voltages. Direct connection to the mains outlet would cause tripping of the ground fault switch. Refer to the next chapter on how to set up the AC LISN in a standard laboratory environment.

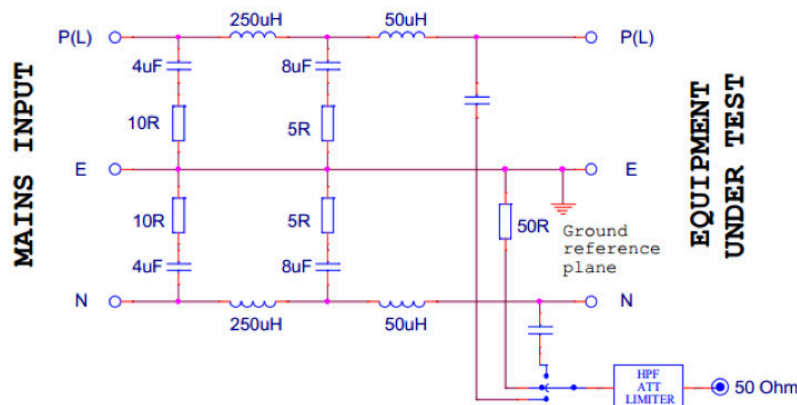

Figure 2 – AC LISN, informative schematic

1.5. LABORATORY SET UP

The DUT shall be isolated and elevated from the ground plane. The spectrum analyzer shall measure the conducted emissions on both line and neutral.

The value of the parallel combination of the capacitors is 12 μ F from line and neutral to ground. This causes around 0.75A flowing into the earth connection and would trip the ground fault switch. Hence, an insulation

transformer is required for any mains supply which is protected by a residual current device or ground fault (earth leakage) circuit breaker and good grounding is essential for safety.

For the exact details of the set up and for the limits of conducted emissions refer to the CISPR 16 or other relevant applicable standards.

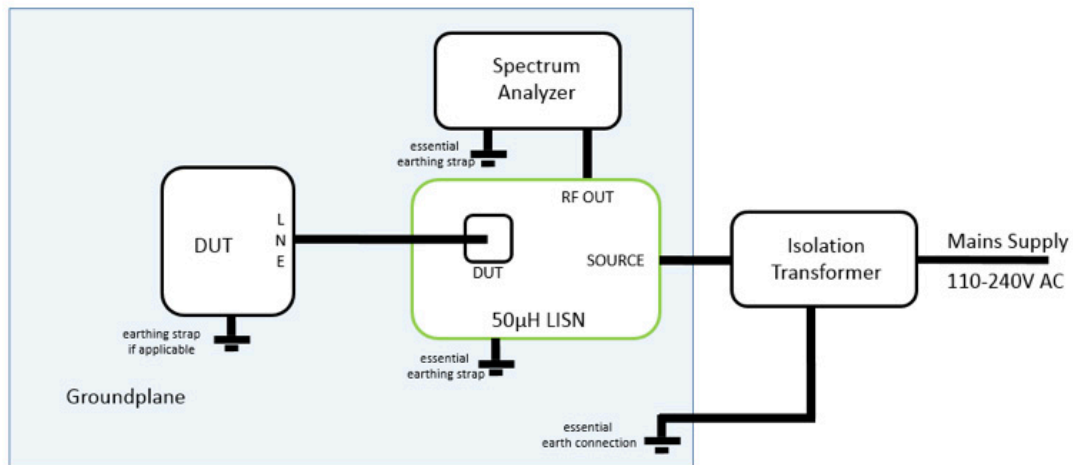

Figure 3 – Conducted noise pre-compliance measurement setup

SAFETY: Ensure that all required earth connections are reliably bonded and that the isolation transformer can supply the required load current.

1.6. GROUND PLANE

Any voltage measurement must be made against a common circuit node which can be referred to as the “zero volt” reference. In order to provide a low impedance zero volt reference for RF measurements, a metal sheet must be provided as ground plane. All ground straps between equipment and ground plane shall be as short as possible and fastened with screws. Exact details on the size of the ground plane

and the arrangement of the equipment and interconnecting cables are described in the applicable standards.

In a pre-compliance test set up, as a rule of thumb, the size of the ground plane shall be large enough to accommodate all involved equipment and exceed at least 10cm each side.

2. TBLC08 SPECIFICATIONS

2.1. CONFORMITY

The TBLC08 is compliant with Safety Class I according IEC 1010-1.
(EN 61010-1: 1993 / IEC (CEI) 1010-1: 1990 A 1: 1992, EN 61010-1/A2: 1995 / IEC 1010-1/A2: 1995 /)
Rated Pollution degree: 2
Overvoltage category: II
EMC: EN61326-1/A1

2.2. SAFETY

In order to ensure safe operations, the user must follow all safety relevant information of this manual. All housing parts are connected with the earth conductor of the power conductor and with the ground

strap block at the rear panel of the housing. It is not allowed to carry out any modifications or manipulations of the TBLC08.

2.3. SPECIFICATIONS

- Frequency range: 9 kHz to 30 MHz
- Impedance: 50 Ω || (50 μ H + 5 Ω)
- Artificial hand: 220 pF + 511 Ω
- Switchable PE: 50 Ω || 50 μ H
- Limiter / attenuator: 150 kHz to 30 MHz; 10 dB
- Line voltage: max. 240V / 50 – 60 Hz, CAT II
- Max. current: 8A @ 23°C; Fuses: 8A, slow
- DUT socket: country specific
- Measurement connector: 50 Ω BNC
- Power connector: IEC 60320 C13
- Operating Temperature Range:
 - +5°C ... + 40°C; 5% to 80% RH
- Safety: Safety Class I, IEC 1010-01

2.4. SUPPLY VOLTAGE

The TBLC08 does not require any particular voltage settings. It can be operated with any supply voltage which does not exceed 240V, 50Hz/60Hz.

2.5. FRONT PANEL

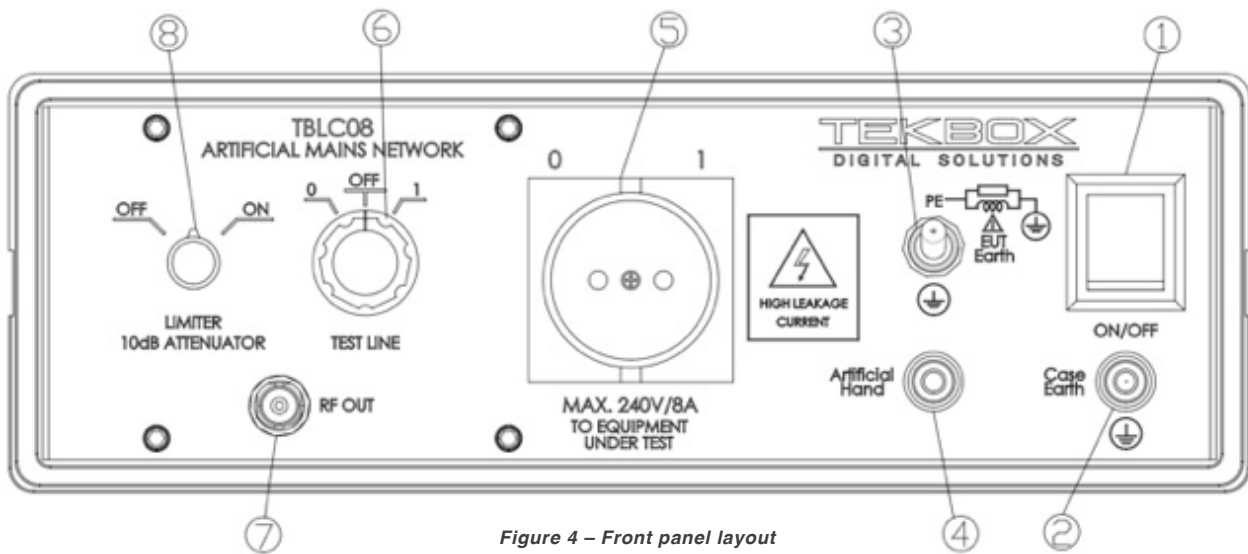

Figure 4 – Front panel layout

- 1) Mains switch
- 2) Auxiliary case earth connector, safety banana jack
- 3) Protective Earth switch to connect DUT earth either directly to case earth, or via $50\mu\text{H} \parallel 50\ \Omega$
- 4) Artificial hand connector, safety banana jack
- 5) DUT socket, country specific
- 6) RF path selection, 0 (neutral), OFF, 1 (phase)
- 7) $50\ \Omega$ RF output, BNC jack
- 8) Limiter + 10 dB attenuator + 150kHz high pass filter switch

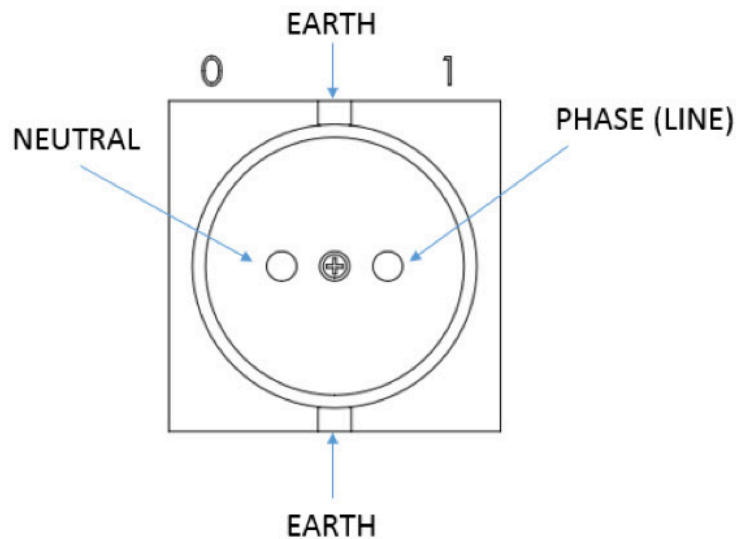

Figure 5 – DUT connector, pin assignment with reference to the rear power connector *)
 *) Provided that the TBLC08 is correctly connected to the mains power outlet

2.6. REAR PANEL

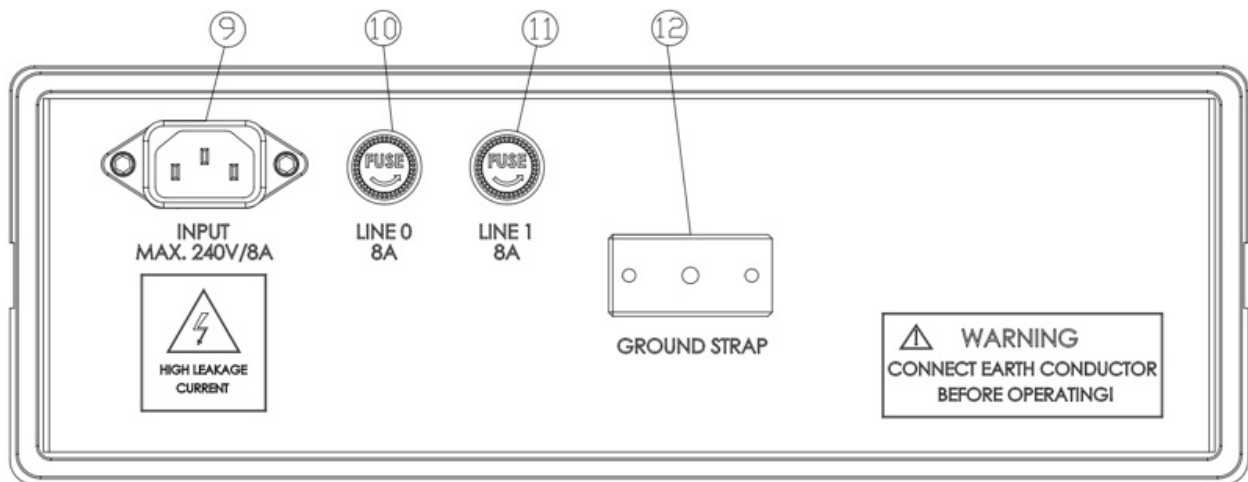

Figure 6 – Rear panel layout

9) Power connector: IEC 60320 C13

10) Fuse, 8A, slow

11) Fuse, 8A, slow

12) Ground strap block, connected to earth, 4mm thread

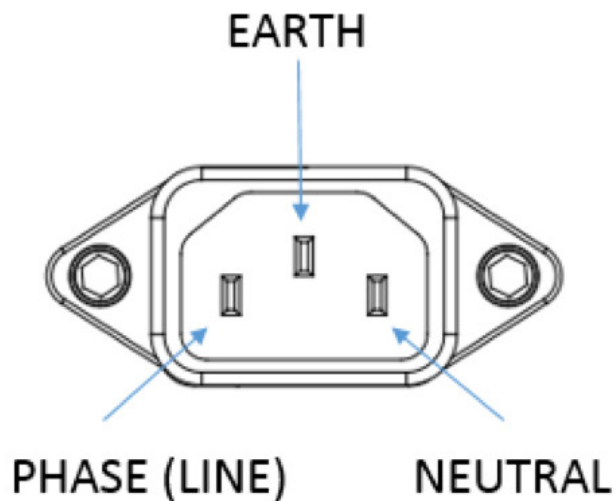

Figure 7 – Mains connector, pin assignment *)

*) Provided that the TBLC08 is correctly connected to the mains power outlet

2.7. IMPEDANCE

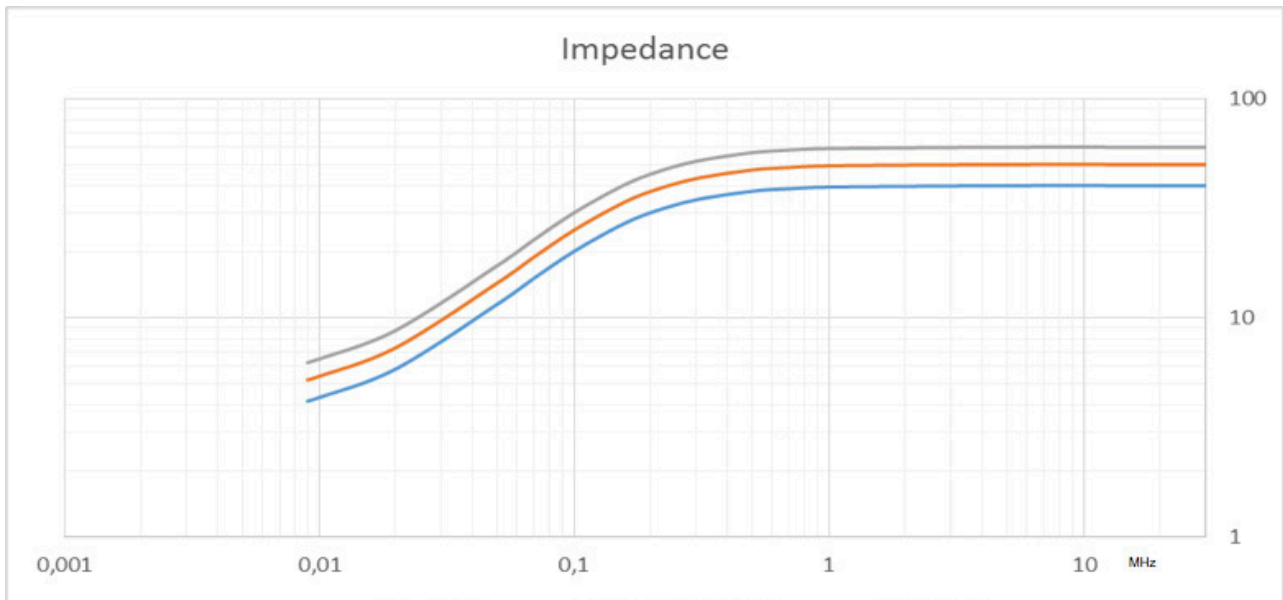

Figure 8 – impedance vs. frequency at DUT terminals

2.8. FREQUENCY RESPONSE, S21 FROM DUT PORT TO RF PORT

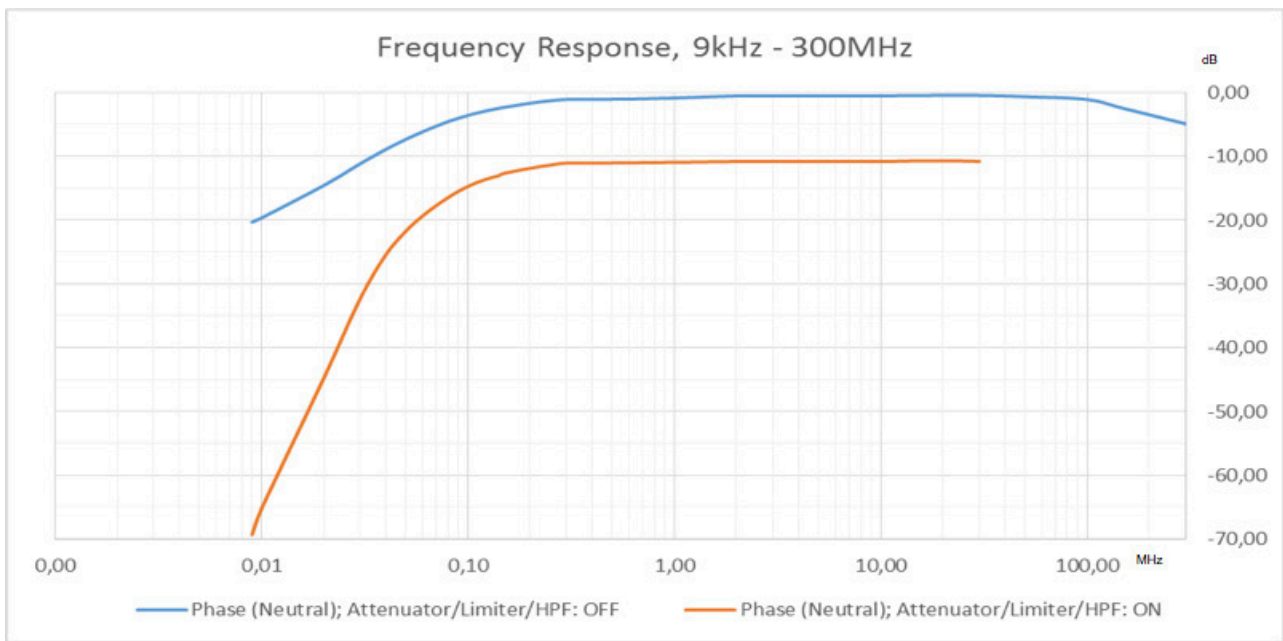

Figure 9 – Frequency response 9kHz to 300MHz, DUT connector Phase/Neutral to RF connector

Frequency [MHz]	Path: DUT connector – RF connector [dB] Phase (Neutral); Att./Limiter/HPF: OFF	Path DUT connector – RF connector [dB] Phase (Neutral); Att./Limiter/HPF: ON
0,009	-20,30	-69,30
0,01	-19,64	-65,23
0,02	-14,57	-44,79
0,03	-11,18	-32,36
0,04	-8,90	-25,43
0,05	-7,33	-21,73
0,06	-6,17	-19,39
0,07	-5,28	-17,74
0,08	-4,56	-16,46
0,09	-4,03	-15,46
0,10	-3,58	-14,72
0,11	-3,23	-14,13
0,12	-2,94	-13,68
0,13	-2,70	-13,34
0,14	-2,49	-13,07
0,15	-2,32	-12,66
0,20	-1,67	-11,87
0,25	-1,29	-11,37
0,30	-1,08	-11,06
0,40	-1,06	-11,04
0,50	-1,04	-11,03
0,60	-1,02	-11,02
0,70	-0,98	-10,98
0,80	-0,94	-10,97
0,90	-0,89	-10,94
1,00	-0,86	-10,93
2,00	-0,53	-10,81
3,00	-0,52	-10,79
4,00	-0,52	-10,81
5,00	-0,52	-10,81
10,00	-0,51	-10,80
15,00	-0,48	-10,72
20,00	-0,44	-10,71
25,00	-0,45	-10,73
30,00	-0,45	-10,80
50,00	-0,64	
100,00	-1,10	
150,00	-2,50	

Table 1 – Frequency response 9kHz to 300MHz, DUT connector Phase/Neutral to RF connector

2.9. CALIBRATION DATA ACCORDING TO CISPR 16 -1-2 ANNEX A8

Calibration set up according to CISPR 16-1-2 Annex A.8.

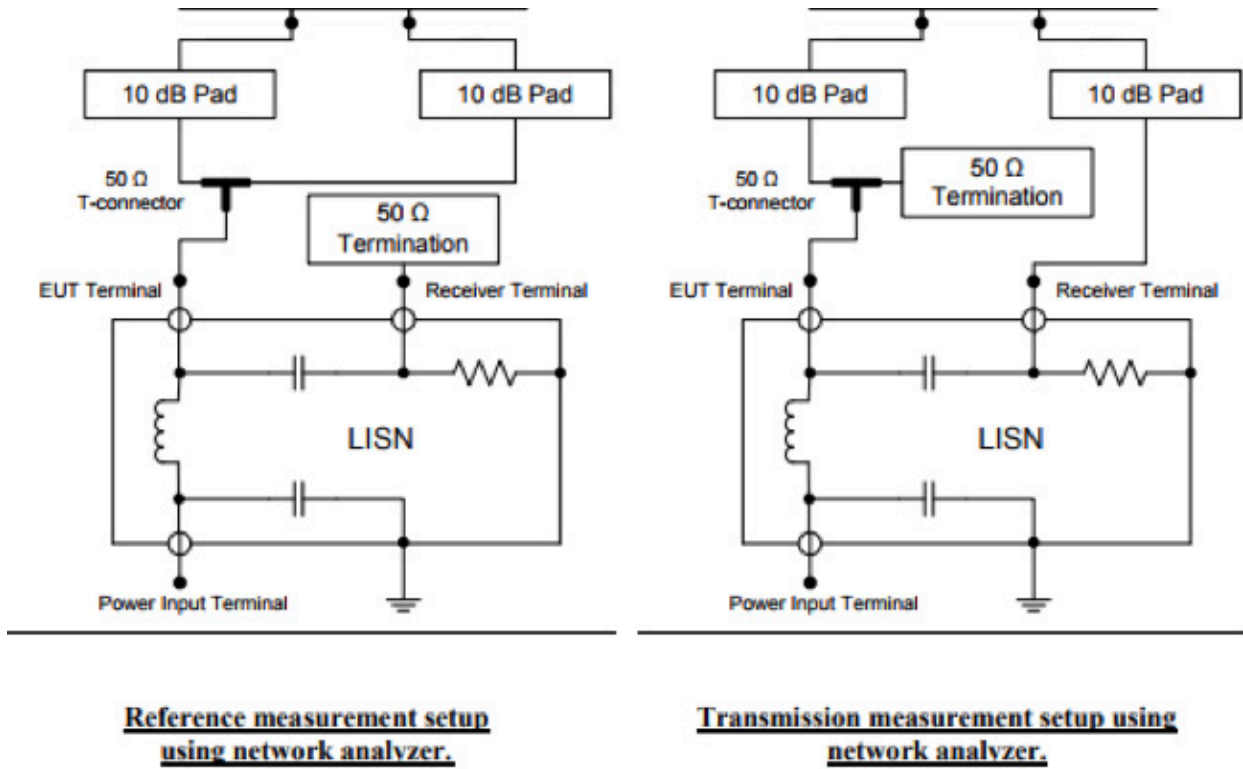

Figure 10 – Calibration set up according to CISPR 16-1-2 Annex A.8.

Frequency [MHz]	Insertion loss neutral/phase attenuator/limiter off [dB]	Insertion loss neutral/phase - attenuator/filter/limiter on [dB]
0.03	-1.22	-23.4
0.05	-0.78	-15.8
0.1	-0.54	-12.2
0.15	-0.5	-11.4
0.25	-0.49	-10.95
0.3	-0.48	-10.88
0.35	-0.46	-10.72
0.4	-0.46	-10.72
0.45	-0.46	-10.72
0.5	-0.46	-10.72
0.55	-0.47	-10.72
0.6	-0.47	-10.72
0.65	-0.47	-10.72
0.7	-0.47	-10.72
0.75	-0.47	-10.72
0.8	-0.47	-10.72
0.85	-0.47	-10.72
0.9	-0.47	-10.72

0.95	-0.47	-10.72
1	-0.47	-10.72
2	-0.51	-10.74
3	-0.55	-10.78
4	-0.61	-10.81
5	-0.69	-10.89
6	-0.75	-10.92
7	-0.81	-11.01
8	-0.89	-11.07
9	-0.97	-11.14
10	-1.05	-11.24
11	-1.17	-11.33
12	-1.23	-11.37
13	-1.32	-11.47
14	-1.42	-11.59
15	-1.56	-11.73
16	-1.67	-11.85
17	-1.82	-12.03
18	-1.94	-12.16
19	-2.09	-12.29
20	-2.23	-12.48
21	-2.41	-12.67
22	-2.57	-12.84
23	-2.76	-13.05
24	-2.95	-13.29
25	-3.06	-13.51
26	-3.29	-13.65
27	-3.38	-13.78
28	-3.42	-13.81
29	-3.46	-14.86
30	-3.51	-13.95

Table 2, TBLC08 LISN calibration data

2 10. PROTECTION

The TBLC08 offers several levels of protection to prevent surges appearing at the input of the measurement receiver or analyzer. Both the neutral line and phase line are equipped with a 275V varistor to ground. The RF path is always protected by a 90V gas discharge tube and a pair of TVS diodes (5.4V break down voltage, 9.8V clamping

voltage, 1A peak surge current). When the attenuator/limiter switch is in "ON" position, a 10dB attenuator and a Schottky diode limiter offer additional protection. Furthermore, the attenuator/limiter path contains a 150kHz high pass filter.

2 11. ARTIFICIAL HAND

When performing conducted noise measurements with devices which are held in hand, the artificial hand network mimics the influence of the human hand. Examples for such devices are power tools, hair driers, kitchen tools and similar equipment.

Insulated housing sections that are touched by the hand when operating the equipment are covered with metal foil and connected to the artificial hand jack.

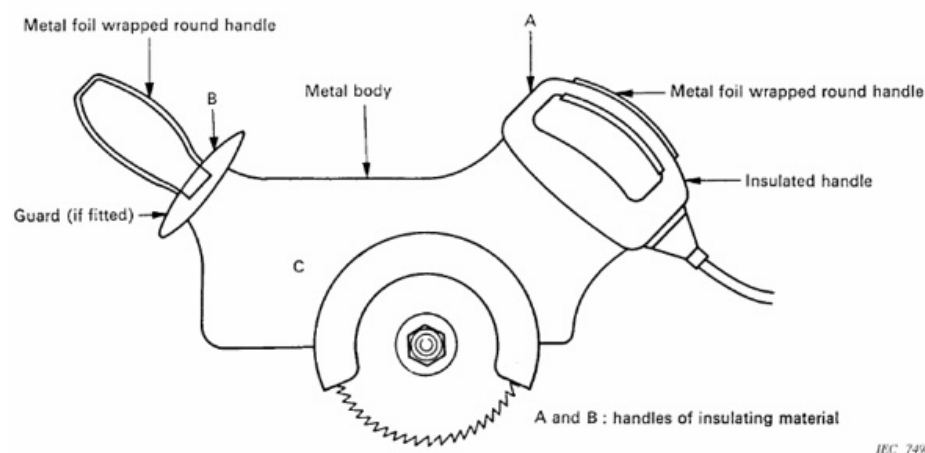

Figure 11 – Example from CISPR 16, portable electric saw with artificial hand

3. OPERATION CHECKLIST

- Setup the isolation transformer, TBLC08, DUT and spectrum analyzer according to Figure 3.
- Before powering the isolation transformer, measure the connectivity between each equipment chassis and ground plane.
- Ensure that the supply cable of the isolation transformer, the supply cable of the LISN, the supply cable of the spectrum analyzer and if applicable the supply cable of the DUT contain a ground conductor.
- Ensure that the line selection switch of the TBLC08 is set to "OFF".
- Ensure that the Protective Earth switch is set to direct ground position
- Ensure that the Limiter/Attenuator switch of the TBLC08 is in "ON" position.
- Ensure that the power switch of the TBLC08 is in "OFF" position.
- Ensure that the DUT power switch is in "OFF" position.
- Power on the isolation transformer
- Power on the analyzer, set frequency, bandwidth, amplitude etc.
- Power on the TBLC08
- Power on the DUT
- Set the line selection switch to "0" or "1" to carry out the conducted noise measurements. Disengage the Limiter/Attenuator for better sensitivity and in order to avoid potential intermodulation.
- After finishing the measurement, proceed in reverse order. Take special care to set the limiter/attenuator to "ON" and the line selection switch to "OFF" before powering off the DUT.

4. ORDERING INFORMATION

Part Number	Description
TBLC08-EU	50μH LISN with Schuko socket (CE7/3)
TBLC08-US	50μH LISN with US socket (NEMA 5-15, grounded, type B)
TBLC08-AU	50μH LISN with Australian socket (AS/NZS 3112:201)
TBLC08-GB	50μH LISN with English socket (BS1363)
TBLC08-xx	Any other socket requirements upon customer request will have 2-3 weeks lead time

Table 3 – Ordering Information

5. HISTORY

Version	Date	Author	Changes
V1.0	22.05.2015	MRH	Creation of the document
V1.1	29.06.2015	MRH	Update
V1.2	29.06.2015	MRH	Updated chapter 1.3
V1.3	13.12.2017	MRH	Updated chapter 1.3 and added chapter 2.9

Table 4 – History