

Product Datasheet - Technical Specifications



More information in our Web-Shop at ► www.meilhaus.com

Your contact

Technical and commercial sales, price information,
quotations, demo/test equipment, consulting:

Tel.: +49 - (0)81 41 - 52 71-0

E-Mail: sales@meilhaus.com

Meilhaus Electronic GmbH
Am Sonnenlicht 2
82239 Alling/Germany

Tel. +49 - (0)81 41 - 52 71-0 E-
Mail sales@meilhaus.com

Mentioned company and product names may be registered trademarks of the respective companies. Errors and omissions excepted. © Meilhaus Electronic.

5 μ H Line Impedance Stabilisation Network

Introduction

The TBL05100-1 is a universal 5 μ H LISN that meets the requirements of several standards. The TBL05100 is factory jumpered to 50 Ω // 5 μ H + 1 Ω , fulfilling the CISPR 16-1-2 and CISPR 25 impedance, phase an isolation specification. By setting internal jumper, it can be converted into 50 Ω // 5 μ H variants that support standards such as CISPR 25, MIL-STD-461G, ISO11452-4 and ISO 7637-2. By adding an external 10F capacitor, the impedance will fulfil DO-160 specifications.

The LISN is inserted into the EUT's (Equipment Under Test) supply line. Conducted noise at the EUT's supply terminals can be monitored at the BNC connector with a spectrum analyzer or a measurement receiver. A 5 μ H inductor decouples the source (supply) terminal from the EUT terminal.

The use of two TBL05100-1 in conjunction with the Tekbox LISN Mate allows for the measurement of common mode and differential mode noise separately. The unit comes equipped with a BNC-male to N-male RG232 cable, mating connectors and ground brackets to attach it to a ground plane.



Picture 1: TBL05100-1

1 Parameters

Topology: single path, configurable, 50 Ω // 5 μ H + 1 Ω , 50 Ω // 5 μ H; the internal capacitor can be disconnected for ISO 7637-2 and DO-160 set ups; an external 10 μ F capacitor is available for DO-160; the LISN is factory setup to 50 Ω // 5 μ H + 1 Ω , other configurations require setting of an internal high current jumper

Supported standards: CISPR 16-1-2, CISPR 25, MIL-STD-461G, DO-160, ISO11452-4 and ISO 7637-2

Characterized frequency range: 10 kHz – 400 MHz

DC Resistance: < 5 m Ω Source+ to EUT+; < 5 m Ω Source- to EUT-

Maximum current: 100A; see plot with heat up characteristics, chapter 8

Nominal operating voltage range: 0 – 250V AC/DC;

Component ratings: 350V AC, 50/60 Hz; 1000V DC

High current plug / screw terminals; male: Phoenix Contact 1762741, female: Phoenix Contact 1762592; 2 pcs female terminal blocks are supplied as default accessories

Jumper: Harwin D3087-98

Dimensions: 300 mm x 150 mm x 150 mm Weight: 2.7 kg

5 μ H Line Impedance Stabilisation Network

2 Warning

Spectrum Analyzer / Measurement Receiver protection:

The TBL05100-1 LISN does not contain any protective elements in the RF path. Use an external attenuator and/or limiter to protect the spectrum analyzer / measurement receiver input from harmful transients or high RF noise levels.

Safety:

Because of the CISPR 16-1-2, CISPR 25 (EN 55025), MIL-STD-461G and DO-160 design requirements, LISNs do not do not comply with the maximum permissible leakage current as specified in EN61010-1. Furthermore, LISNs do not fulfil the isolation requirements of CAT II.

The LISN housing is connected to the negative / ground SOURCE and EUT pin of the terminal block and the ground of the RF connector. Inadvertently connecting the positive voltage or line voltage to the ground pin puts you at risk of a lethal electric shock. The TBL05100-1 is exclusively for use in laboratories and must be operated by qualified personnel.

3 Principle schematic

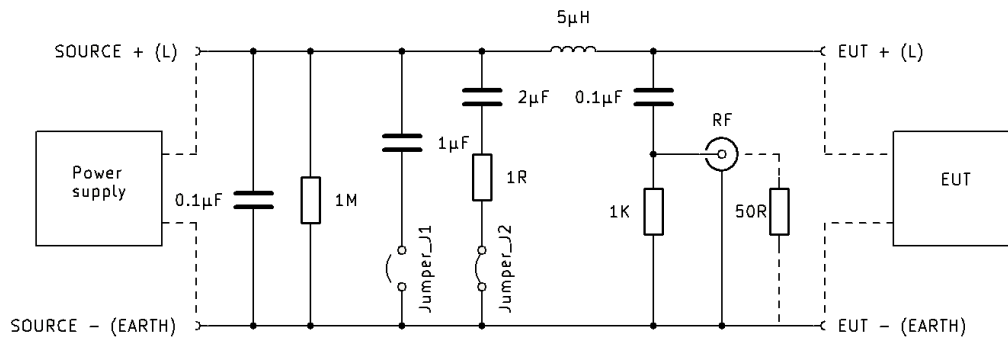

Picture 2: principle schematic

Standards	Jumper J1	Jumper J2
CISPR 16-1-2; CISPR 25: 50 Ω // 5 μ H + 1 Ω	open	shorted
CISPR 25, MIL-STD-461G, ISO 11452-4: 50 Ω // 5 μ H	shorted	open
DO-160; 10 μ F capacitor attached to source terminals	open	open
ISO 7637-2	open	open

To access the jumpers, the housing cover must be removed. Re-attach it after setting the jumpers. Refer to the table above, or to the table on the silkscreen print of the PCB.

5µH Line Impedance Stabilisation Network

4 Impedance

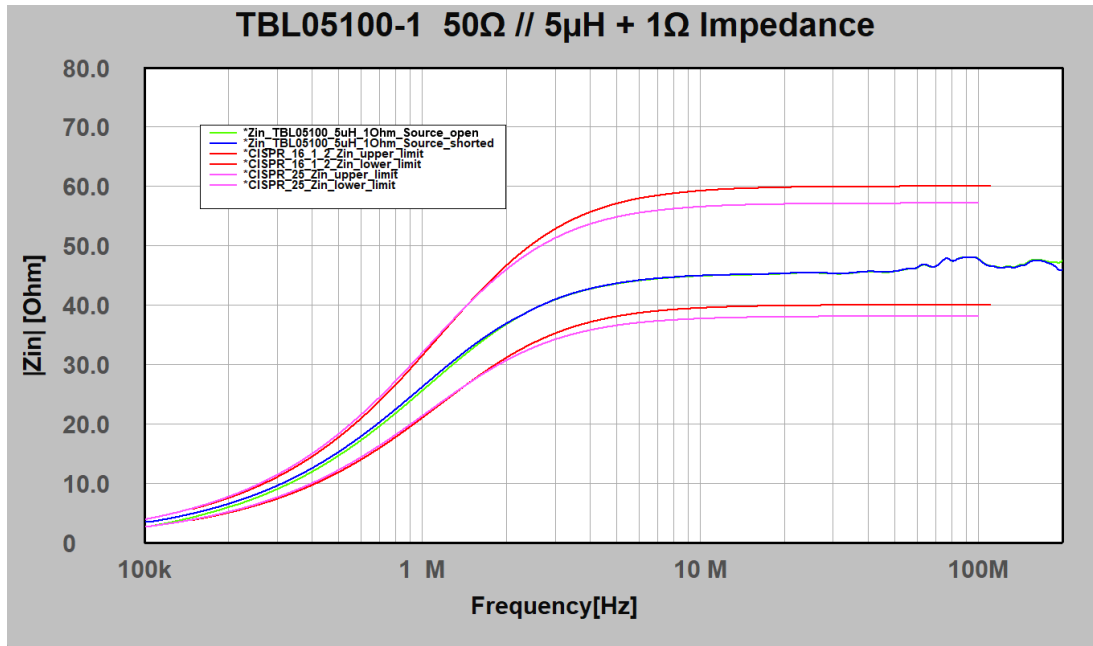

Picture 3: LISN impedance, 100 kHz – 110MHz; 50Ω // 5µH+1Ω; Jumper J1 open, Jumper J2 shorted

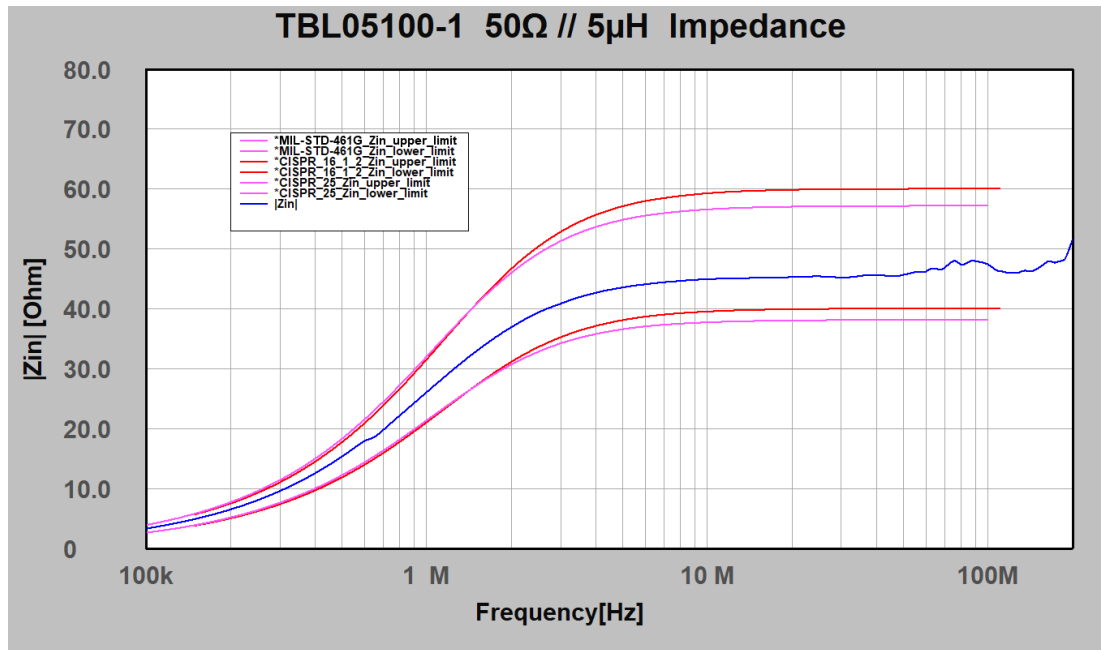

Picture 4: LISN impedance, 100 kHz – 110MHz; 50Ω // 5µH; Jumper J1 shorted, Jumper J2 open

5 μ H Line Impedance Stabilisation Network

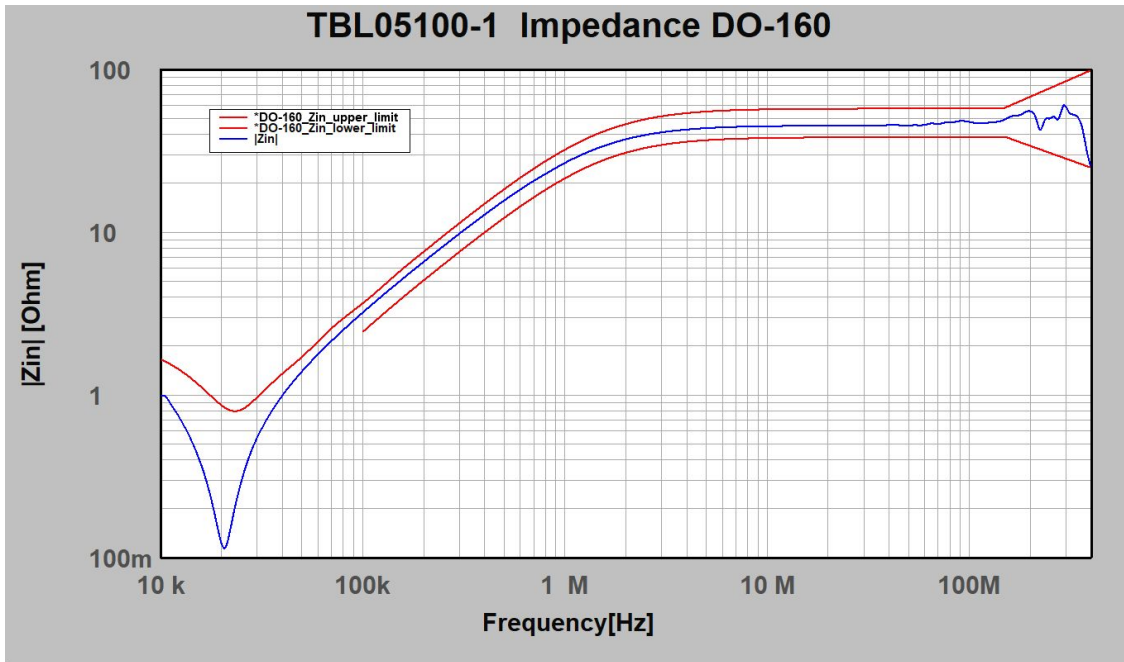

Picture 5: LISN impedance, 10 kHz – 400MHz; 50 Ω // 5 μ H; Jumper J1 open, Jumper J2 open, external 10 μ F capacitor connected at the source port

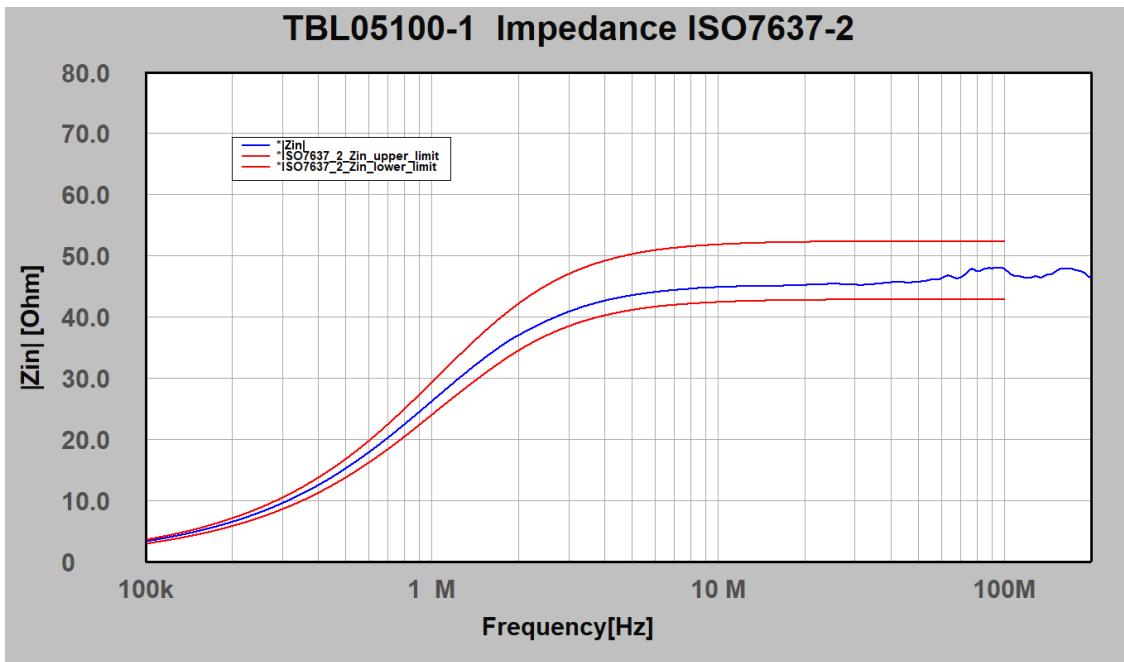

Picture 6: LISN impedance, 100 kHz – 100MHz; 50 Ω // 5 μ H; Jumper J1 open, Jumper J2 open

5µH Line Impedance Stabilisation Network

5 Phase

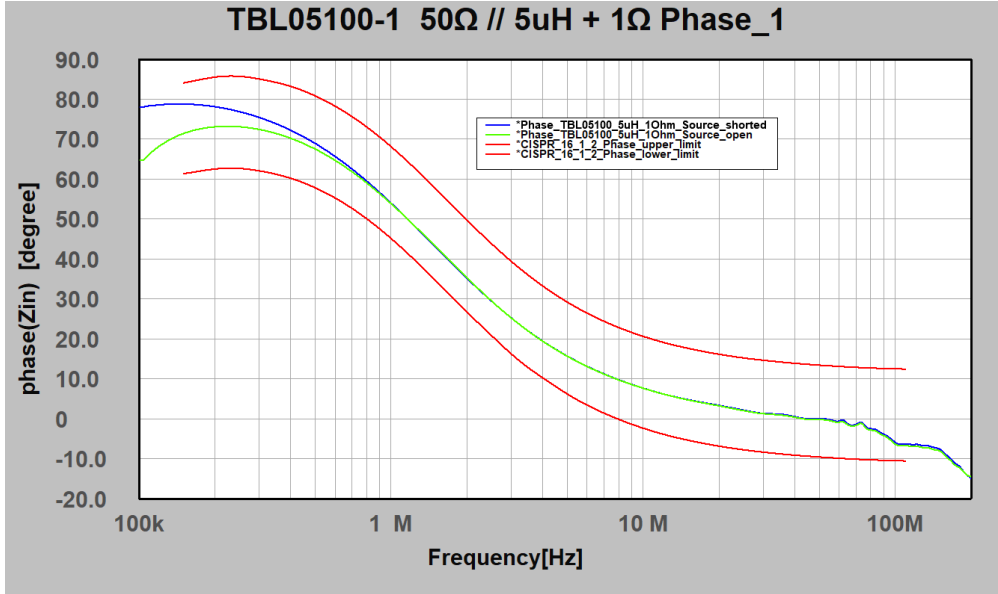

Picture 7: LISN phase, 100 kHz – 110MHz; 50Ω // 5µH+1Ω

6 Isolation

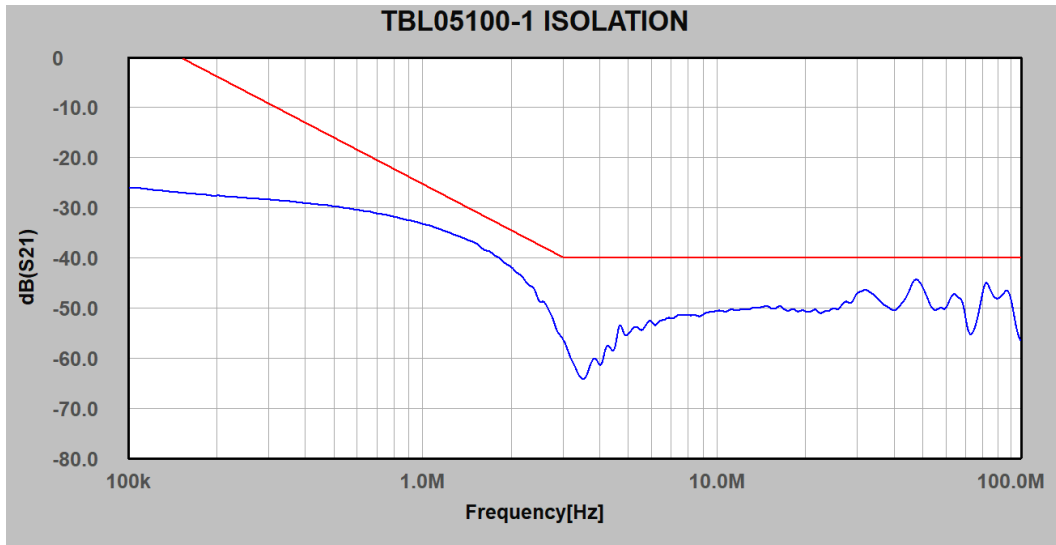

Picture 8: LISN Isolation, 100 kHz – 110MHz, 50Ω // 5µH+1Ω

The isolation is measured between SOURCE port and RF port, with the EUT port terminated with 50 Ohm.

5 μ H Line Impedance Stabilisation Network

7 Thermal characteristics

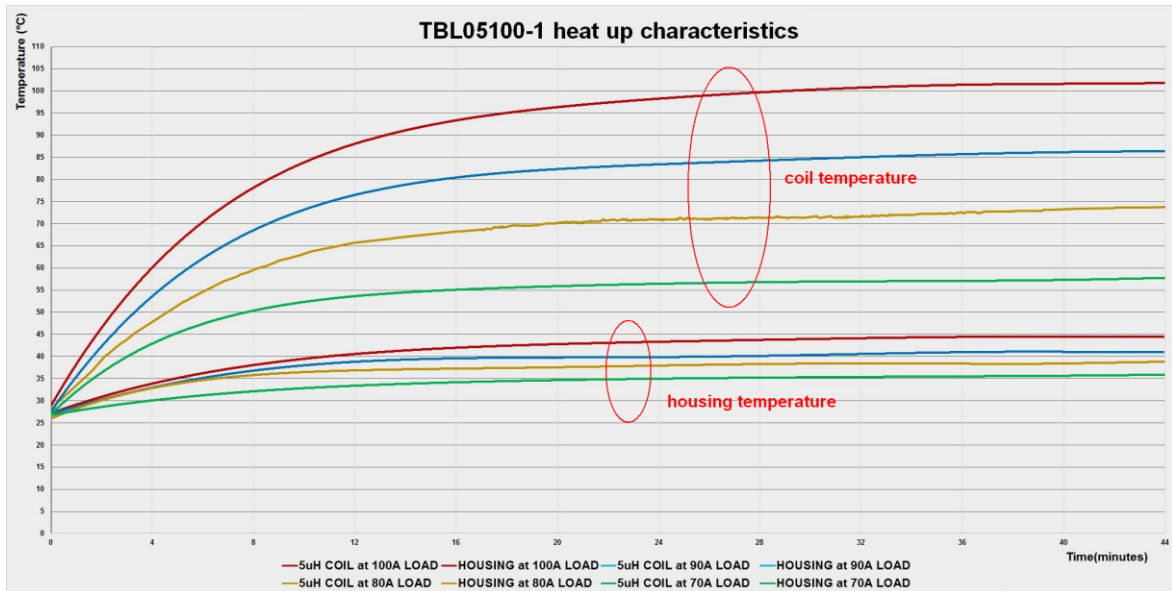

Picture 9: Coil and housing temperature, measured at 27°C ambient temperature

8 Voltage division ratio according to CISPR 16 -1-2 Annex A8

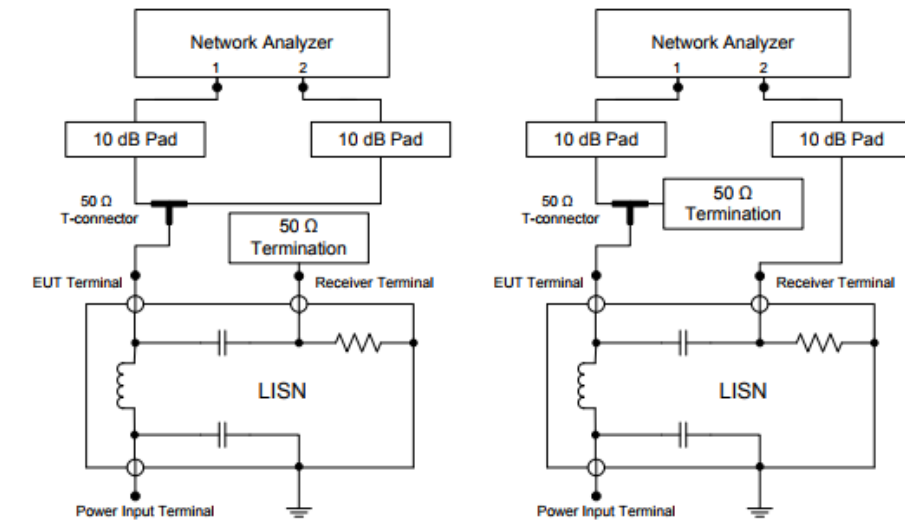

Reference measurement setup using network analyzer.

Transmission measurement setup using network analyzer.

Picture 10: Calibration set up according to CISPR 16-1-2 Annex A.8.

5 μ H Line Impedance Stabilisation Network

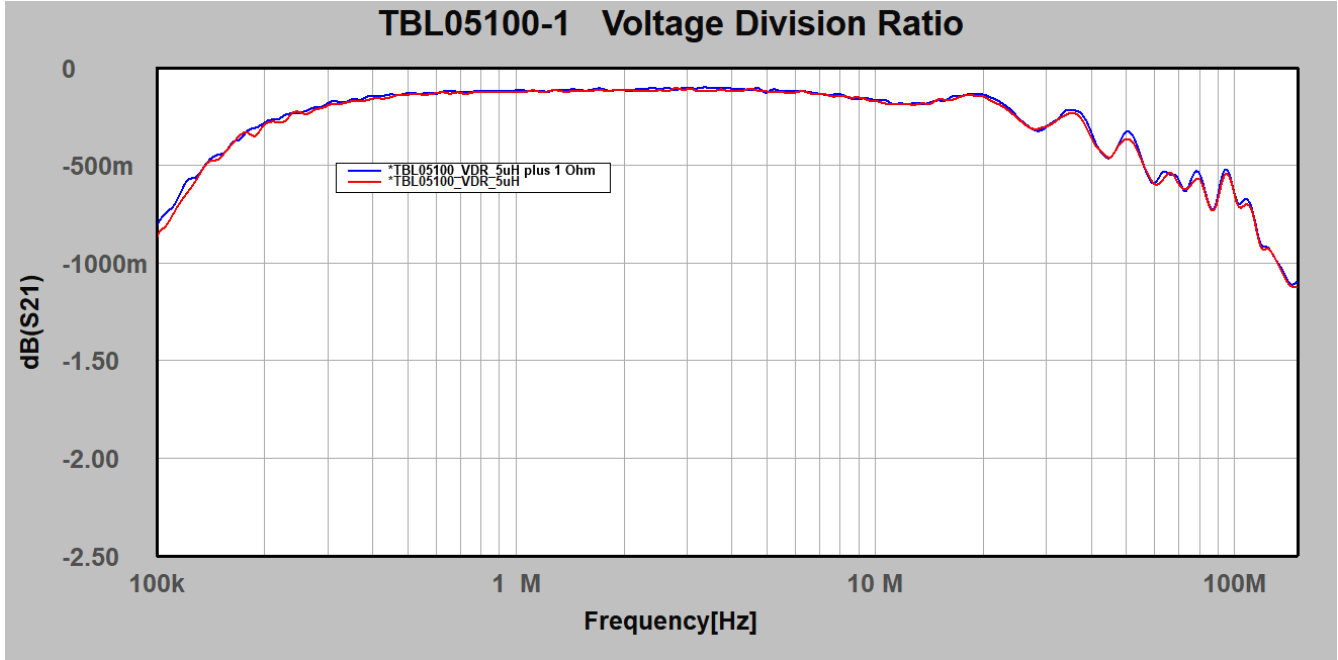

Picture 11: Voltage division ratio EUT terminals to RF connector; 100kHz – 200 MHz; 50 Ω // 5 μ H+1 Ω ; 50 Ω // 5 μ H

Frequency [MHz]	VDR [dB] 50 Ω // 5 μ H+1 Ω	VDR [dB] 50 Ω // 5 μ H	Frequency [MHz]	VDR [dB] 50 Ω // 5 μ H+1 Ω	VDR [dB] 50 Ω // 5 μ H
0.1	-0,81	-0,88	10	-0,17	-0,17
0.125	-0,57	-0,61	20	-0,14	-0,15
0.15	-0,45	-0,47	30	-0,30	-0,30
0.175	-0,35	-0,34	40	-0,33	-0,36
0.2	-0,28	-0,29	50	-0,33	-0,37
0.25	-0,23	-0,23	60	-0,59	-0,60
0.5	-0,13	-0,14	70	-0,57	-0,60
0.75	-0,13	-0,13	80	-0,55	-0,57
1	-0,12	-0,12	90	-0,66	-0,68
1.2	-0,12	-0,13	100	-0,64	-0,65
1.5	-0,12	-0,12	110	-0,69	-0,71
2	-0,12	-0,12	120	-0,92	-0,93
2.5	-0,11	-0,12	130	-0,98	-0,98
5	-0,13	-0,12	140	-1,08	-1,10
7.5	-0,14	-0,14	150	-1,09	-1,12

Table 1 - Voltage division ratio

5 μ H Line Impedance Stabilisation Network

9 Application

The abbreviation LISN stands for Line Impedance Stabilisation Network.

- It is a low pass filter typically placed between a power source and the supply terminals of a device under test (EUT).
- It has a feed-through path to supply the EUT with power
- It provides a well-defined RF-impedance to the EUT
- It couples electrical noise generated by the EUT to a 50 Ω RF port, which can be connected to a spectrum analyser or measurement receiver
- It suppresses electrical noise from the supply side towards the EUT
- It suppresses electrical noise from EUT side towards the supply

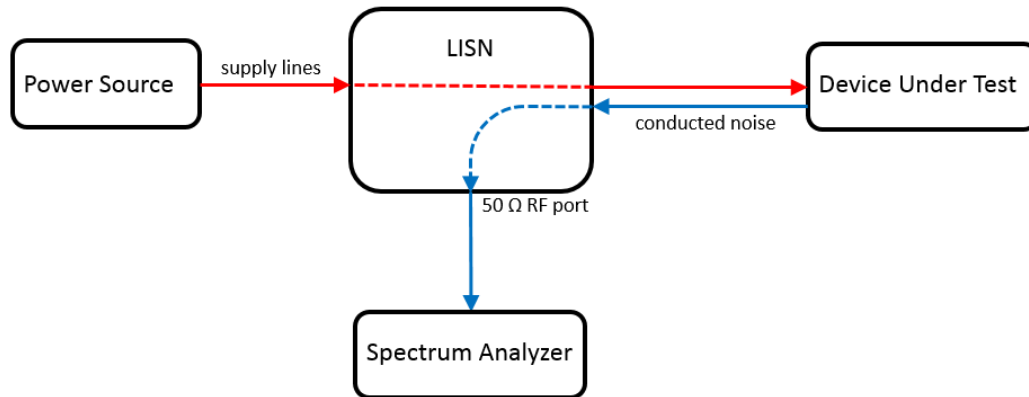

Picture 12: Basic diagram of a conducted emission measurement setup with a LISN

Further applications such as conducted noise measurements using RF current monitoring probes, radiated emission tests, BCI tests and voltage transient tests require LISNs to establish a defined supply line impedance.

9.1 Conducted Emission Measurement Setup, Voltage Method

CISPR 25 specifies two measurement configurations:

If the EUT is grounded to the vehicle chassis with a power return line shorter than 20 cm in length, a single LISN is adequate, and the conducted noise is monitored only on the positive supply line.

If the power return line of the EUT is longer than 20 cm, two LISNs are required. One LISN connects the positive supply line to the EUT, and another LISN connects the power return line to the EUT. Conducted noise is measured on both lines. It is actually measured on one LISN at a time, with the other LISN's RF port terminated with a 50 resistor.

Professional noise measurements are performed in shielded chambers since any ambient noise picked up by the wires connecting LISN to EUT or by the EUT itself will be present at the RF terminal. In pre-compliance setups, a test should be performed with the EUT turned off to distinguish between conducted noise generated by the EUT and emissions from other sources (ambient noise). Tekbox provides low cost, desktop shielded tents or shielded bags to suppress ambient noise for pre-compliance conducted noise measurements.

5 μ H Line Impedance Stabilisation Network

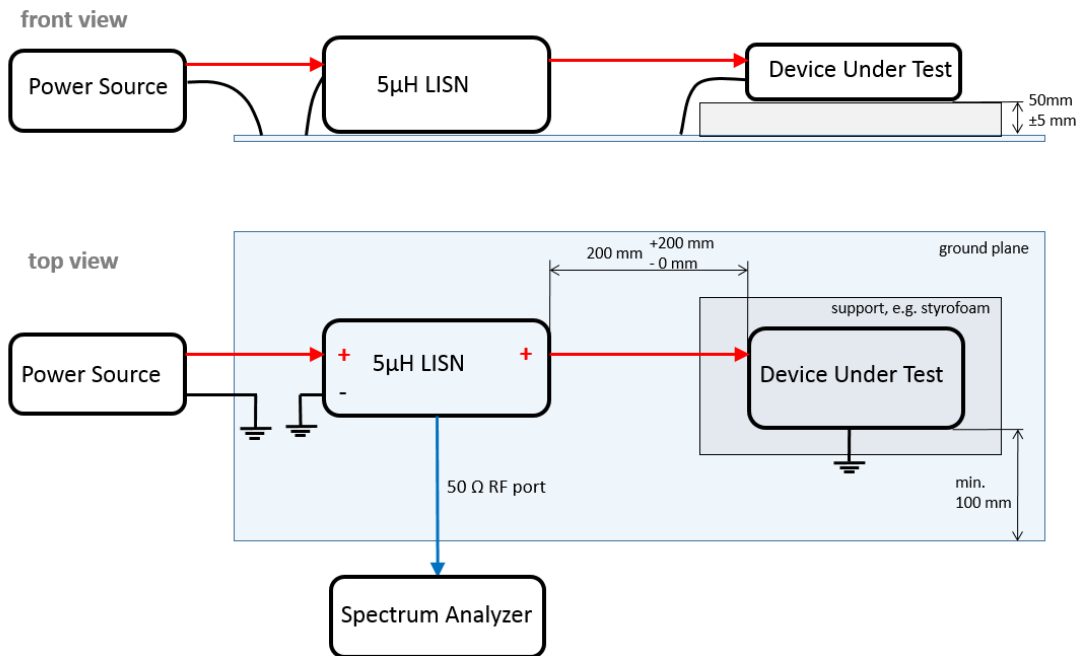

Picture 13: conducted emission measurement, voltage method, EUT with power return line locally grounded

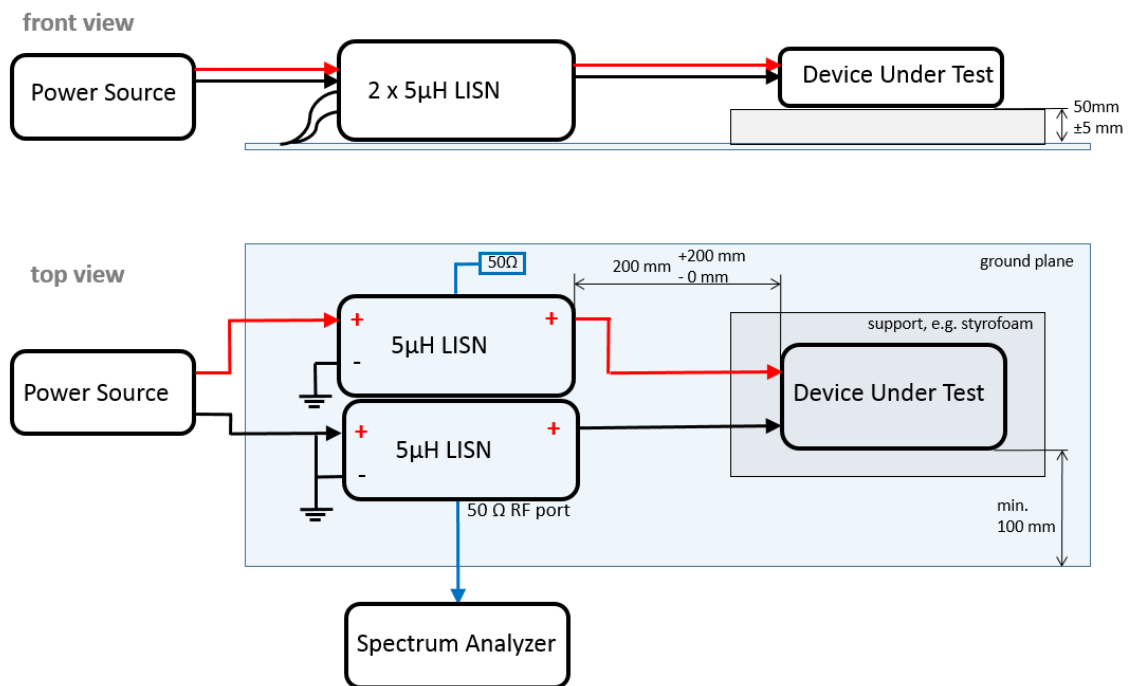

Picture 14: conducted emission measurement, voltage method, EUT with power return line remotely grounded

5 μ H Line Impedance Stabilisation Network

Figures 3 and 4 depict conducted noise measurement setups using the voltage method, as specified in CISPR 25. If the EUT is connected to additional peripheral devices, they should also be connected or emulated using a load box. If a remotely powered EUT's housing is designed for chassis grounding, it should also be grounded to the ground plane. The grounding lead should be no more than 150mm length.

Because most devices are remotely grounded, the configuration shown in Figure 4 is more frequent. The measurement must then be performed alternately on both the positive and negative power lines. The unused RF port is always terminated with 50 Ohm.

It should be noted that conducted noise testing per DO160 necessitates the insertion of a 10 μ F capacitor across the LISN's source terminals.

9.2 Conducted emission measurement set up, current probe method

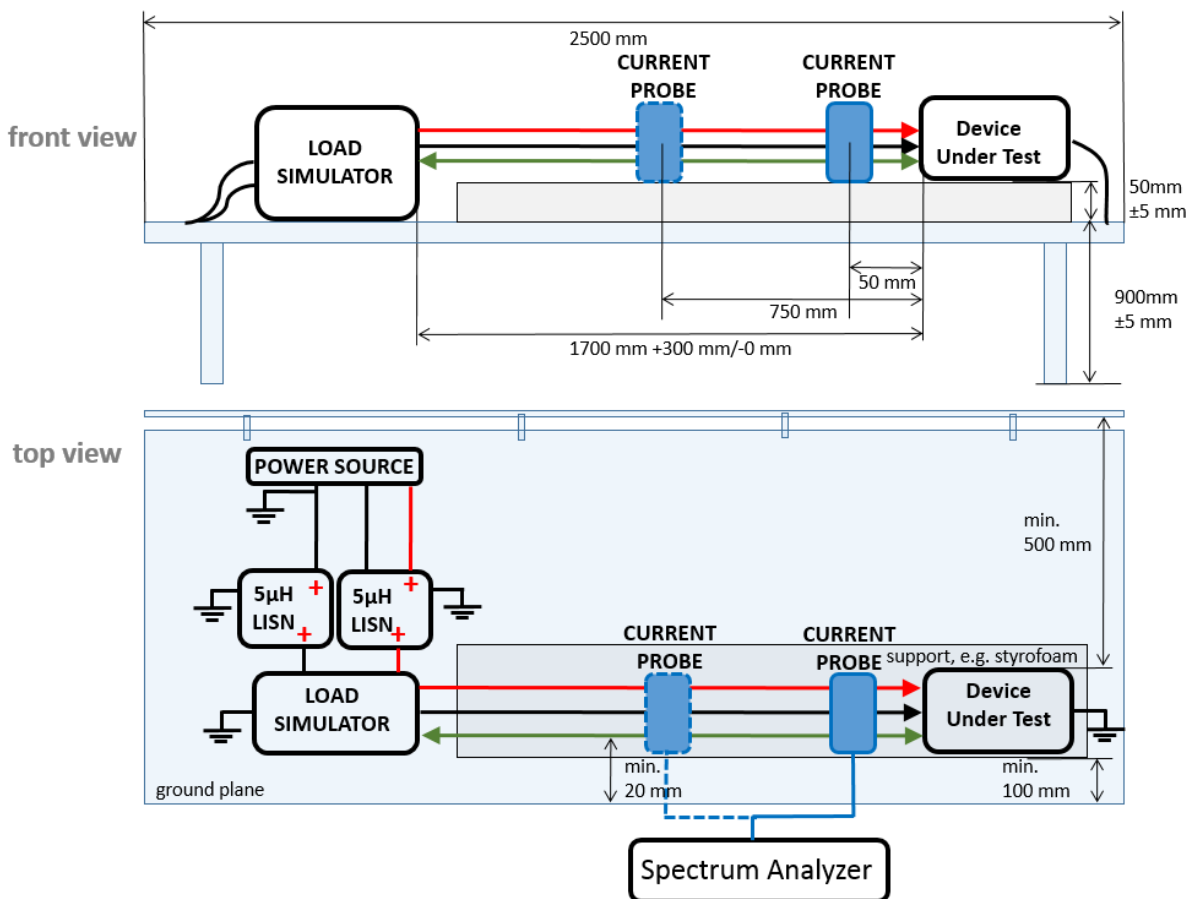

Picture 15: conducted emission measurement according to CISPR 25, current probe method

The CISPR 25 current probe measurement is used to monitor conducted emissions on a wire harness, including control/signal lines of an EUT. Some vehicle manufacturers utilise the wide bandwidth of current probes to measure conducted emissions on power supply lines over a wider frequency range than LISNs can. Measurements are typically taken on various lines – plus, minus, control signals, plus + minus, plus + minus +

5µH Line Impedance Stabilisation Network

control lines. In order to account for cable harness resonance effects, the current probe is measured at 50 mm and 750 mm distances from the EUT. Each LISN's RF output must be terminated with 50 Ohm. The current probe picks up the conducted emissions. To establish a defined impedance on the power lines, two LISNs are necessary. The load simulator is a specially designed device that simulates the load existing at the EUT's signal/control interface.

9.3 Bulk Current Injection

Immunity tests performed in accordance with ISO11452-4 employ a configuration similar to that used for current probe-based conducted emission measurements. However, instead of using a current probe to measure conducted emissions, a signal generator / power amplifier feeds an interferer signal into the BCI probe. Again, two LISNs are required to establish a defined supply impedance. The LISNs' RF output must be terminated with an external 50 Ohm termination with enough power handling capacity.

9.4 Voltage transient testing

The TBL05100 can be configured to meet the impedance specifications of ISO 7637-2. Chapter 4 contains the appropriate jumper configuration.

10 Ordering Information

Part Number	Description
TBL05100-1	5µH LISN, 2pcs. female terminal blocks Phoenix Contact 1762592, 1 pc. 75 cm BNC-male to N-male RG223 cable Calibration certificate and NIST traceable calibration data

Table 2 – Ordering Information

11 History

Version	Date	Author	Changes
V1.0	7.6.2023	Mayerhofer	Creation of the document

Table 3 – History