

## Product Datasheet - Technical Specifications

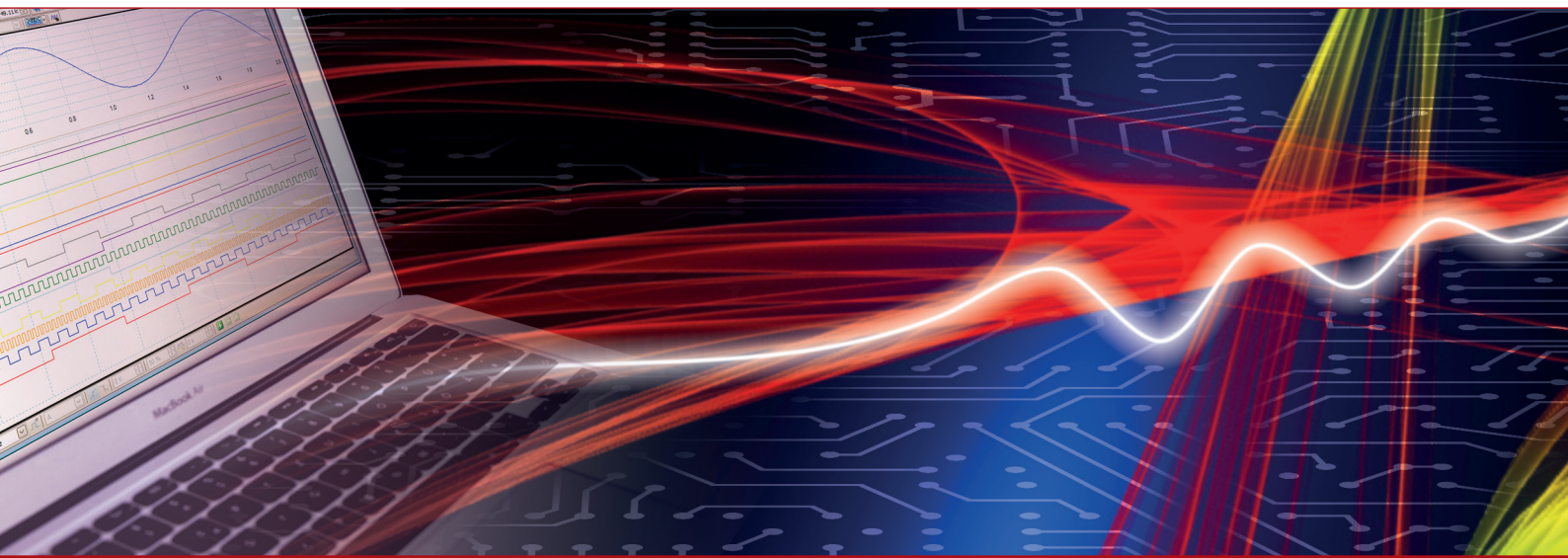

More information in our Web-Shop at ► [www.meilhaus.com](http://www.meilhaus.com) and in our download section.

### Your contact

**Technical and commercial sales, price information,  
quotations, demo/test equipment, consulting:**

Tel.: **+49 - 81 41 - 52 71-0**

FAX: **+49 - 81 41 - 52 71-129**

E-Mail: [sales@meilhaus.com](mailto:sales@meilhaus.com)

Downloads:

[www.meilhaus.com/en/infos/download.htm](http://www.meilhaus.com/en/infos/download.htm)

**Meilhaus Electronic GmbH** | Tel. **+49 - 81 41 - 52 71-0**  
Am Sonnenlicht 2 | Fax **+49 - 81 41 - 52 71-129**  
82239 Alling/Germany | E-Mail [sales@meilhaus.com](mailto:sales@meilhaus.com)

Mentioned company and product names may be registered trademarks of the respective companies. Prices in Euro plus VAT. Errors and omissions excepted.  
© Meilhaus Electronic.

[www.meilhaus.de](http://www.meilhaus.de)

# Compact Series

## TR Models



COPPER MOUNTAIN™  
TECHNOLOGIES



- **Frequency range:** 20 kHz - 4.8 GHz
- **Wide output power adjustment range:** -50 dBm to +5 dBm
- **Dynamic range:** 125 dB (10 Hz IF bandwidth) typ.
- **Measurement time per point:** 70  $\mu$ s per point, min typ.
- Up to **16 logical channels with 16 traces** each max
- **Automation programming** in LabView, Python, MATLAB, .NET, etc.
- Models available in **50 or 75 Ohm**
- **Time domain and gating** conversion included
- **Frequency offset mode**, including vector mixer calibration measurements
- Up to **200,001 measurement points**
- Multiple **precision calibration** methods and automatic calibration

EXTEND YOUR REACH™

# Full featured lab grade performance in a compact package

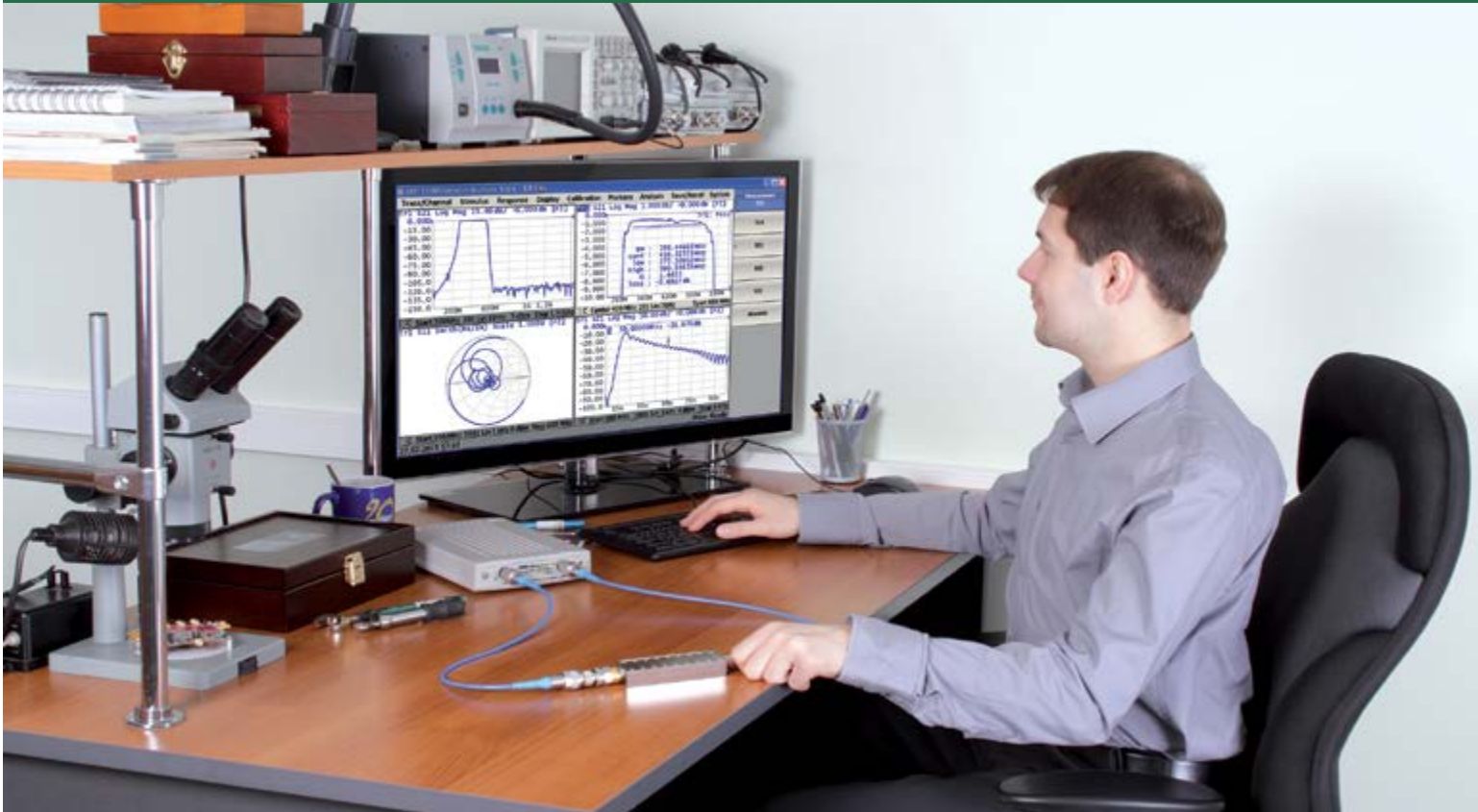

Our Compact Series VNAs deliver lab grade performance in a compact package, with all the features engineers have come to expect included: time domain and gating conversion, segmented frequency sweeps, linear/logarithmic sweeps, power sweeps, multiple trace formats, 16 channels max. with up to 16 traces each, marker math, and limit tests.

Versatile and portable Copper Mountain Technologies' Compact analyzers can be powered by battery and are ideal for use by specialists working in the field, as well as laboratory and production testing in a wide variety of industries including design and production of RF components, cable CPEs, medical devices, aerospace, etc.

Copper Mountain Technologies' USB VNAs are next generation analyzers designed to meet the needs of 21st Century engineers. Our VNAs include an RF measurement module and a processing module, a software application which runs on a Windows or Linux PC, laptop, or tablet, connecting to the measurement hardware via USB interface.

This innovative approach delivers high measurement accuracy and enables users to take advantage of faster processors, newer computers and larger displays. USB VNAs have lower Total Cost of Ownership and fewer potential failure points.

These instruments are smaller and lighter, can go almost anywhere, are very easy to share and eliminate the need for data purging or hard drive removal in secure environments.

# The Whole Solution

## *Warranty, Service, & Repairs*

All our products come with a standard three-year warranty from date of shipment. During that time we will repair or replace any product malfunctioning due to defective parts or labor.

While we pride ourselves on quality of our instruments, should your VNA malfunction for any reason, we will gladly offer a loaner unit while we service yours. With our USB VNAs where all data is stored on your PC, a simple swap of the measurement module assures uninterrupted workflow. So you will experience little or no downtime.

## *Our engineers are an extension of your team*

Our team of applications engineers, service technicians, and metrology scientists are here to help you with technical support, application-specific recommendations, annual performance testing, and troubleshooting or repair of your CMT instruments.

Our engineers will work with your team to augment your in-house capabilities. We can write custom applications and test software, develop test automation scripts and help with integrated RF system testing. We can design and provide an RF switching network specific to your requirements; electro-mechanical, solid-state, or PIN diode-based. If the S-parameter measurement fixture involves challenging conditions for repeatability and accuracy we can assist with measurement uncertainty analysis.

## *Annual Calibration*

Copper Mountain Technologies' Indianapolis calibration laboratory is accredited in accordance with the recognized international standard ISO/IEC 17025:2017 and meets the requirements of ANSI/NC SL Z540-1994-1. All reference standards and equipment in the laboratory are traceable to National Institute of Standards and Technology (NIST) or international equivalent.

Should you prefer to perform the annual testing yourself or use a third party, contact us for information or questions on performing these procedures. Additionally, the VNA Performance Test (VNAPT) software application is available for third party laboratories without restriction. Use of VNAPT to execute performance tests is optional, but the software is designed to automate and streamline VNA performance testing, including automatic generation of test reports. Please contact Copper Mountain Technologies or your local distributor for recommended calibration options.



"CMT devices are lightweight, compact and a necessary tool for technical sales or engineers on the go. The software interface allows users to test RF products with any standard computer system. This is a revolution and a relief in terms of space occupied in the lab, measurement reliability and dynamic range. CMT provides the highest level of timely and attentive customer care."

**Jessy Cavazos**  
*Industry Director, Frost & Sullivan*

# Software Application

## Software application is part of the VNA

The software application takes raw measurement data from the data acquisition (measurement) module and recalculates into S-parameters in multiple presentation formats utilizing proprietary algorithms. These new and advanced calibration and other accuracy enhancing algorithms were developed by our metrology experts. Our software can be downloaded free from our website, used on an unlimited number of PCs using either Linux or Windows operating systems, and enables easy VNA integration with other software applications and automation.

The software application features a fully functioning Demo Mode, which can be used for exploring VNAs' features and capabilities

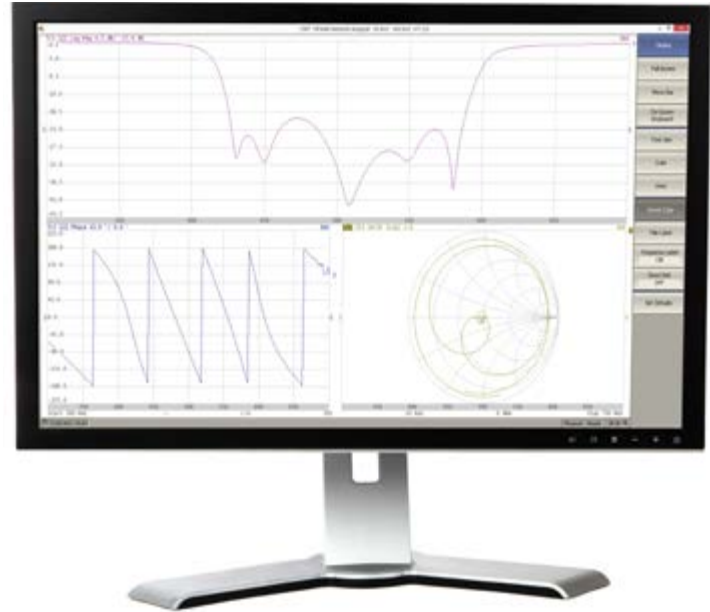

## Measurement Capabilities

Measured parameters

$$S_{11}, S_{21}$$

All models also measure absolute power of the reference and received signals at the port.

Number of measurement channels

Up to 9 independent logical channels: each logical channel is represented on the screen as an individual channel window. A logical channel is defined by such stimulus signal settings as frequency range, number of test points, or power level.

Data traces

Up to 8 data traces can be displayed in each channel window. A data trace represents one of such parameters of the DUT as S-parameters, response in time domain, or input power response.

Memory traces

Each of the 8 data traces can be saved into memory for further comparison with the current values.

Data display formats

Logarithmic magnitude, linear magnitude, phase, expanded phase, group delay, SWR, real part, imaginary part, Smith chart diagram and polar diagram display formats are available.

## Dynamic Range

Typical dynamic range of 123 dB (model dependant) is achieved from 300 kHz through the top of the frequency range (at 10 Hz IF bandwidth). Seen here is the maximum dynamic range achieved when using IFBW 10 Hz and an output power level of 3 dBm.

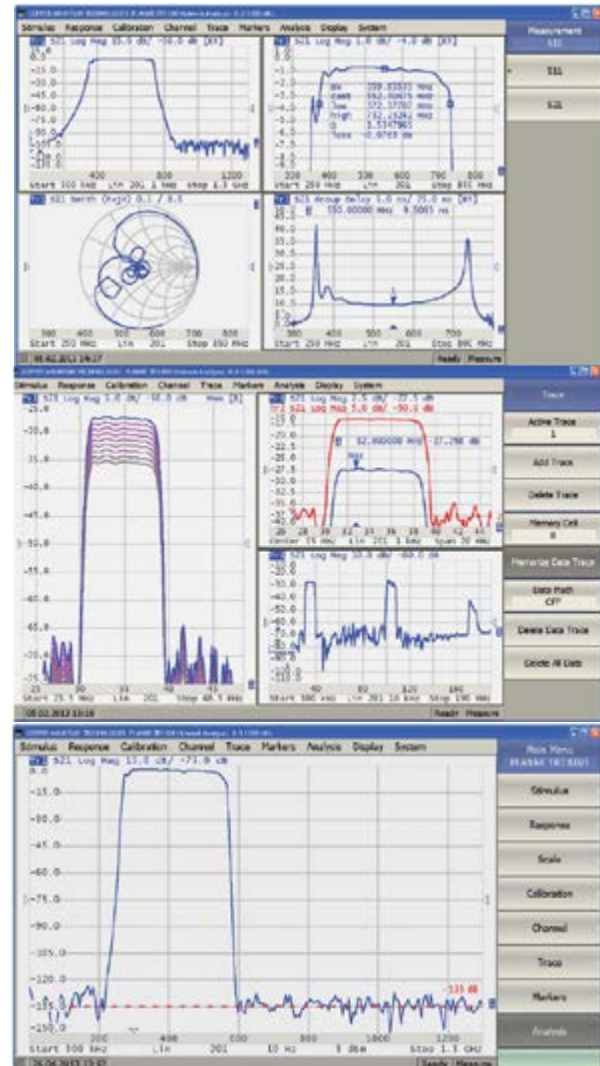

## Sweep Features



**Sweep type:** Linear frequency sweep and logarithmic frequency sweep are performed with fixed output power. Linear power sweep is performed at a fixed frequency.

**Measured points per sweep:** Set by the user from 2 to at least 200,001.

**Segment sweep features:** A frequency sweep within several independent user-defined segments. Frequency range, number of sweep points, source power, and IF bandwidth can be set for each segment.

**Output Power:** Source power from -50 dBm to +5 dBm with a resolution of 0.05 dB. In frequency sweep mode power slope can be set up to 2 dB/GHz to compensate for high frequency attenuation in fixture cables.

**Sweep Trigger:**

Trigger modes: continuous, single, or hold.

Trigger sources: internal, manual, external, bus.

## Trace Functions



**Trace display**

Data trace, memory trace, or simultaneous indication of data and memory traces.

**Trace math**

Data trace modification by math operations: addition, subtraction, multiplication or division of measured complex values and memory data.

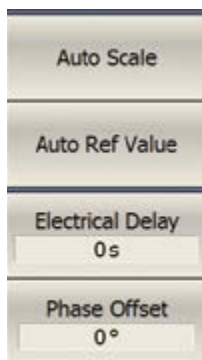

**Autoscaling**

Automatic selection of scale division and reference level value to have the trace most effectively displayed.

**Electrical delay**

Calibration plane moving to compensate for the delay in the test setup. Compensation for electrical delay in device under test (DUT) during measurements of deviation from linear phase.

**Phase offset**

Defined in degrees.

# Software Application

## Frequency Scan Segmentation



The VNA has a large frequency range with the option of frequency scan segmentation. This allows for optimal use of the device to realize the maximum dynamic range while maintaining high measurement speed.

## Power Scanning & Compression Point Recognition



The power sweep feature turns compression point recognition, one of the most fundamental and complex amplified measurements, into a simple and accurate operation.

Pictured here is an TR1300 VNA testing a 50  $\Omega$  amplifier.

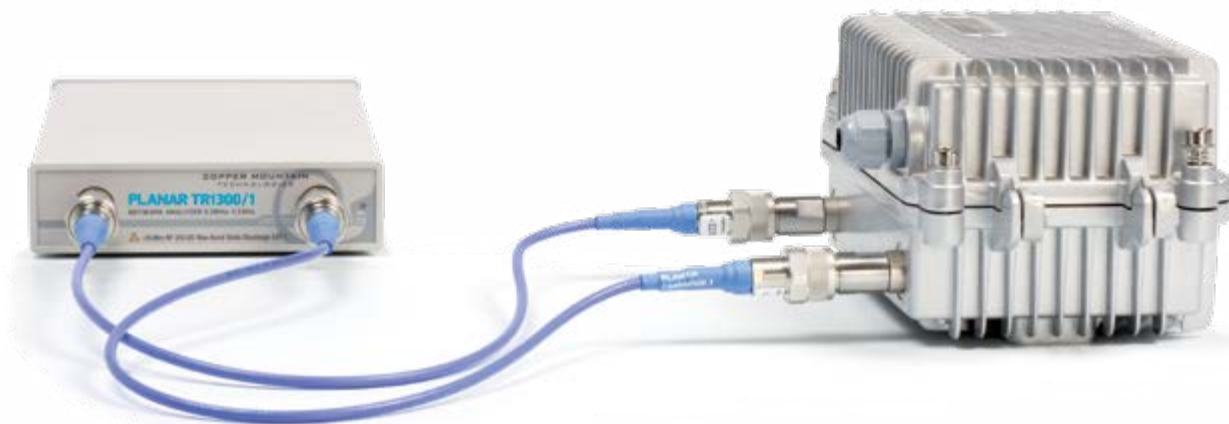

## Mixer/Converter Measurements

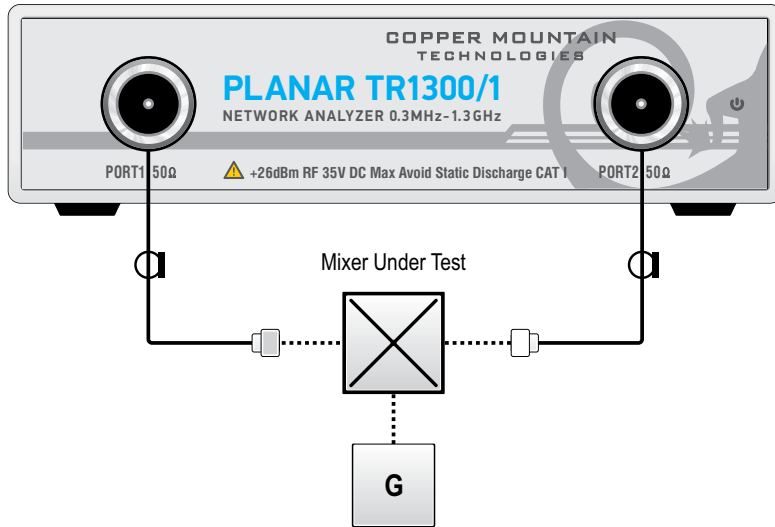

### Scalar mixer/converter measurements

The scalar method allows the user to measure only the magnitude of the transmission coefficient of the mixer and other frequency translating devices. No external mixers or other devices are required. The scalar method employs port frequency offset when there is a difference between the source port frequency and the receiver port frequency.

### Scalar mixer/converter calibration

This is the most accurate method of calibration applied for measurements of mixers in frequency offset mode. The OPEN, SHORT, and LOAD calibration standards are used. An external power meter should be connected to the USB port directly or via USB/GPIB adapter.



### Automatic frequency offset adjustment

This function performs automatic frequency offset adjustment when the scalar mixer/converter measurements are performed to compensate for internal LO setting inaccuracy in the DUT.



# Software Application

## Time Domain Measurements

This function performs conversion from frequency domain into response of the DUT to various stimulus types in time domain. Modeled stimulus types are bandpass, lowpass impulse, and lowpass step. The time domain span is arbitrarily between zero to maximum, which is determined by the frequency step. Windows of various shapes are used for tradeoff between resolution and levels of spurious sidelobes.

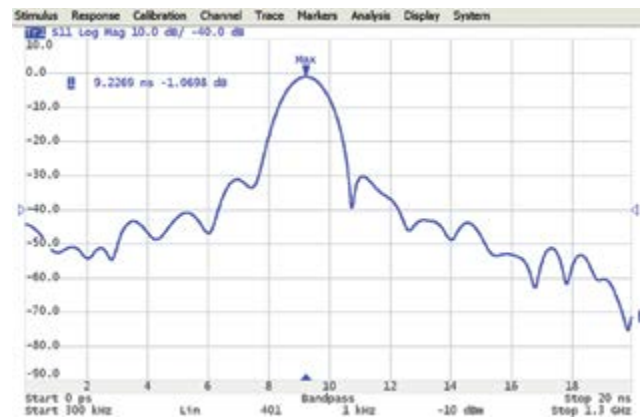
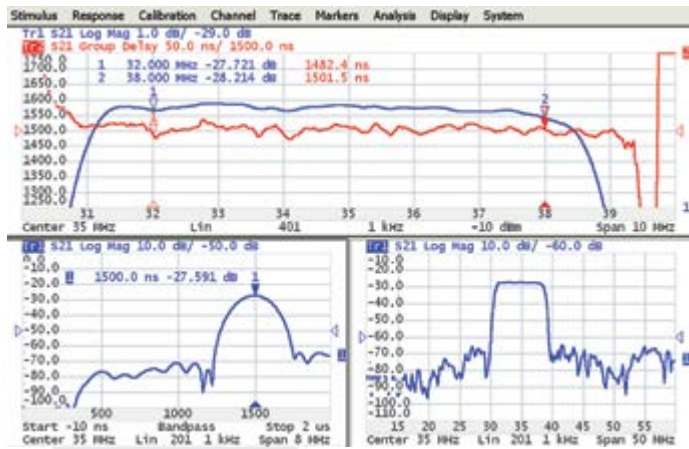

Here, built in time domain analysis allows the user to detect a physical impairment in a cable.

Time domain analysis allows measurements of SAW filters such as the time delay and feedthrough signal suppression.

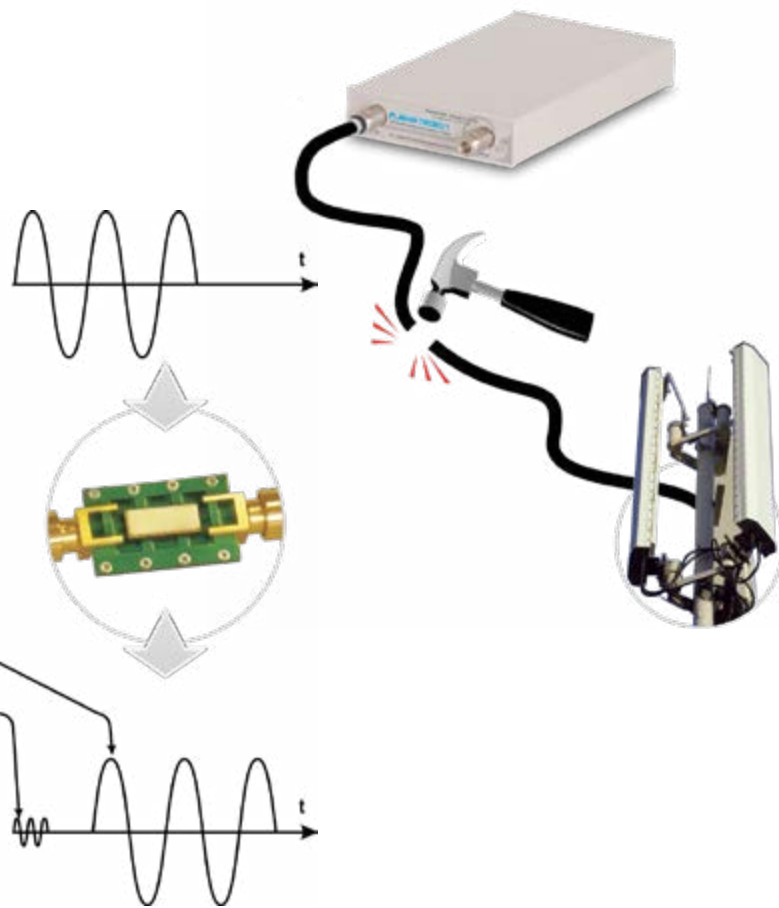
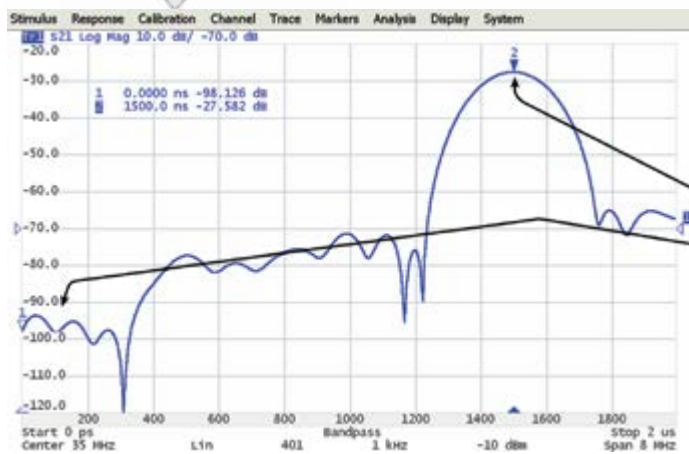

## Time Domain Gating

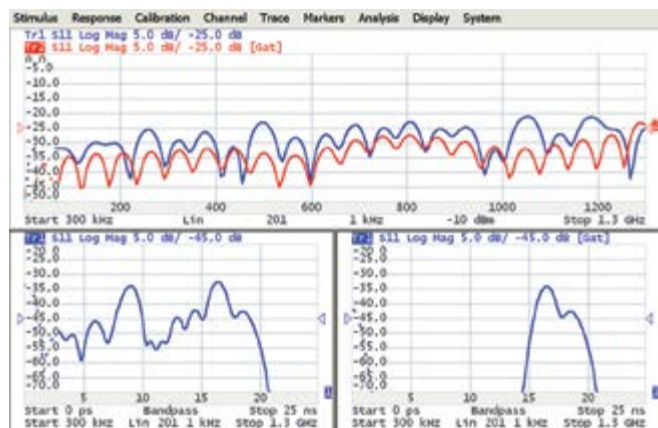

This function mathematically removes unwanted responses in the time domain, which allows the user to obtain a frequency response without effects of fixture elements.

This function applies reverse transformation back to the frequency domain after cutting out the user-defined span in the time domain. Gating filter types are bandpass or notch. For a better tradeoff between gate resolution and level of spurious sidelobes the following filter shapes are available: maximum, wide, normal and minimum.

Applications of these features include, but are not limited to: measurements of SAW filter parameters, such as filter time delay or forward transmission attenuation.

## Limit Testing

Limit testing is a function for automatic pass/fail based on measurement results. Pass/fail is based on comparison of the trace to the limit line set by the user and can consist of one or several segments.

Each segment checks the measurement value for failing either the upper or lower limit, or both. The limit line segment is defined by specifying the coordinates of the beginning (X0, Y0) and the end (X1, Y1) of the segment, and type of the limit. The MAX or MIN limit types check if the trace falls outside of the upper or lower limit, respectively.

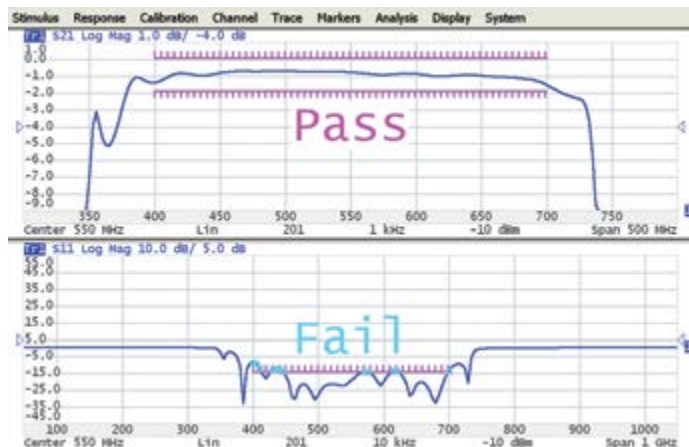
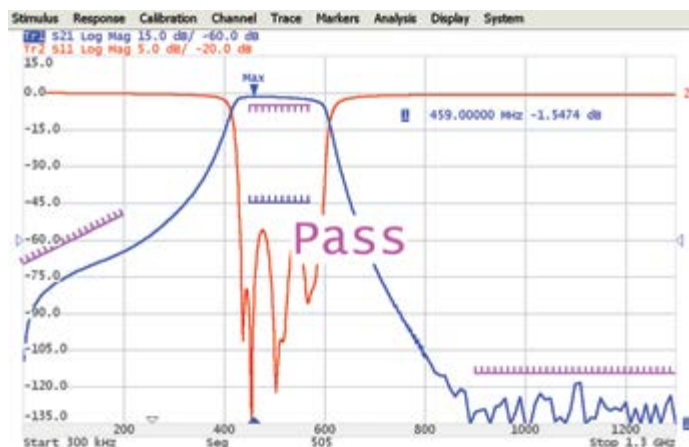

# Software Application

## Embedding

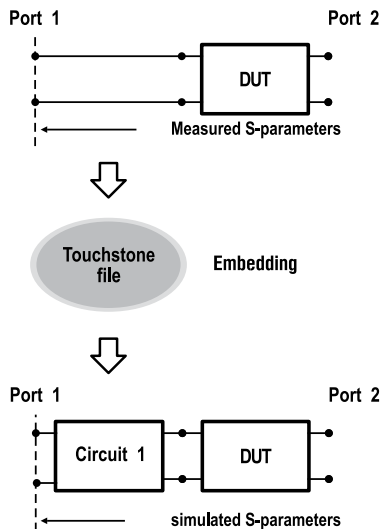

Allows the user to mathematically simulate the DUT parameters after virtual connection through a fixture circuit between the calibration plane and the DUT. This circuit is described by an S-parameter matrix in a Touchstone file.

## De-Embedding

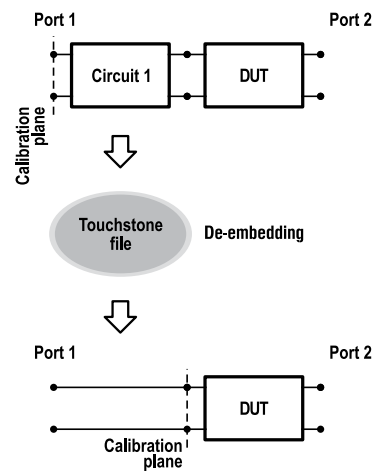

Allows users to mathematically exclude from the measurement result the effect of the fixture circuit connected between the calibration plane and a DUT. This circuit should be described by an S-parameter matrix in a Touchstone file.

## Port Impedance Conversion

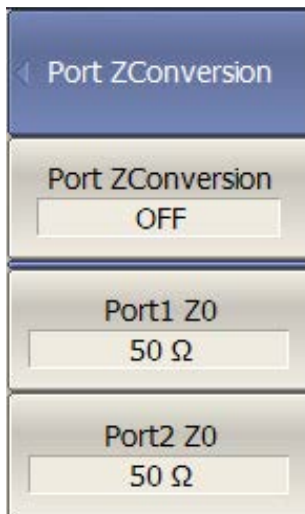

This function converts the S-parameters measured at a 50 Ω port into values which would be seen if measured at a test port with arbitrary impedance.

## S-Parameter Conversion



This function allows for conversion of measured S-parameters to the following parameters: reflection impedance and admittance, transmission impedance and admittance, and inverse S-parameters.

## Data Output



### Analyzer State

All state, calibration and measurement data can be saved to an Analyzer state file on the hard disk and later recalled into the software program. The following four types of states are available: State, State & Cal, Stat & Trace, or All.

### Channel State

A channel state can be saved into the Analyzer state. The procedure is similar to saving of the Analyzer state, and the same types are applied to channel saving. Unlike Analyzer state, channel state is saved into the Analyzer volatile memory (not to the hard disk) and is cleared when power to the Analyzer is switched off. For channel state, there are four memory registers A, B, C, D. Channel state saving allows the user to easily copy the settings of one channel to another one.

### Trace Data CSV File

The Analyzer allows the user to save an individual trace's data as a CSV file (comma separated values). The active trace stimulus and response values, in its current format are saved to a \*.CSV file.

### Trace Data Touchstone File

Allows the user to save S-parameters to a Touchstone file. The Touchstone file contains frequency values and S-parameters. Files of this format are industry-standard for most circuit simulator programs. The .s2p files are used for saving all S-parameters of a device. The .s1p files are used for saving  $S_{11}$  or  $S_{22}$  parameters of a 1-port device. The Touchstone file saving function is applied to individual channels.

### Screenshot capture

A print function is provided with a preview feature, which allows for viewing the image to be printed on the screen, and/or save it to a file. Screenshots can be printed using three different applications: MS Word, Image Viewer for Windows, or the Print Wizard of the Analyzer. Each screenshot can be printed in color, grayscale, black and white, or inverted for visibility or to save ink. The current date and time can be added to each capture before it is transferred to the printing application, resulting in quick and easy test reporting.

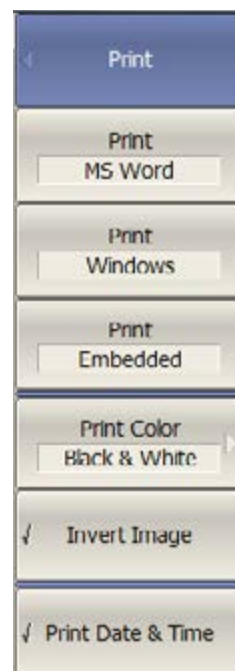

# Calibration

## User Calibration

### Calibration

Calibration of a test setup (which includes the VNA, cables, and adapters) significantly increases the accuracy of measurements. Calibration allows for correction of errors caused by imperfections in the measurement system: system directivity, source and load match, tracking, and isolation.

### Calibration methods

The following calibration methods of various sophistication and accuracy are available:

- Reflection & transmission normalization
- Full one-port calibration
- One-path two-port calibration

### Reflection and transmission normalization

This is the simplest calibration method; however, it provides reduced accuracy compared to other methods.

### Factory Calibration

The factory calibration of Planar TR1300/1 allows for reduction of measurement error in reflection and transmission normalization.

### Full one-port calibration

Method of calibration performed for one-port reflection measurements. It ensures high accuracy.

### One-path two-port calibration

Method of calibration performed for reflection and one-way transmission measurements, for example for measuring  $S_{11}$  and  $S_{21}$  only. It ensures high accuracy for reflection measurements, and moderate accuracy for transmission measurements.

### Mechanical Calibration Kits

The user can select one of the predefined calibration kits of various manufacturers or define a new calibration kit.

### Automatic Calibration Modules

Electronic, or automatic, calibration modules offered by CMT make calibration faster and easier than traditional mechanical calibration.

### Defining of calibration standards

Different methods of calibration standard definition are available: standard definition by polynomial model and standard definition by data (S-parameters).

### Error correction interpolation

When the user changes any settings such as the start/stop frequencies or the number of sweep points, compared to the settings at the moment of calibration, interpolation or extrapolation of the calibration coefficients will be applied.

### Power calibration

Power calibration allows more stable power level setting at the DUT input. An external power meter should be connected to the USB port directly or via a USB/GPIB adapter.

### N1.2 Calibration Kit

The N1.2 calibration kit is suitable for calibration of the Planar TR1300/1 and other vector network analyzers in the frequency range up to 1.5 GHz. While the VNA can be used with any calibration kit on the market suitable for its specifications, the N1.2 is recommended as an economy option for basic calibration.

# Automation

## Automation Languages

We maintain code examples and guides in the following languages:

- MATLAB
  - C++\*
  - LabVIEW
  - Visual Basic (Excel)
  - Python\*
  - And many more
- \*Available for use with Linux operating system

## Measurement Automation

### COM/DCOM interface

The VNA software provides a COM/DCOM (ActiveX) interface, allowing the instrument to be used as a part of a larger test system and in other specialized applications. The VNA program runs as a COM/DCOM server, while the user program runs as a client. COM/DCOM is able to be used with Windows OS only.

### SCPI via TCP Socket

Alternatively a TCP socket is provided for automation from either localhost--the same machine running the VNA software application-- or from a second PC connected by an IP network. The SCPI command is largely compatible with legacy instruments, maximizing code reuse for existing test automation platforms. SCPI via TCP Socket is able to be used with either Windows or Linux operating systems.

### LabView compatible

The device and its software are fully compatible with LabView applications, for ultimate flexibility in user-generated programming and automation.

Our command set is modeled after industry-standard legacy equipment; porting code is straightforward and we can help. Complete installation of any CMT software comes with multiple programming examples and guides installed in the C:\VNA\TRVNA\Programming Examples and Guides directory on Windows or ~/Documents/VNA directory on Linux.

CMT software includes many features that other vendors offer as options, including Time Domain capability, S-parameter Embedding and De-Embedding, and Frequency Offset functionality. No integrated PC means faster data processing turnaround and regular updates that are easy to install. Less complexity in the VNA leads to fewer points of failure that cost you production/development time.

Plugins can add wide ranges of functionality and can be developed upon request. Examples include streamlined production applications, functionality to trigger with external generators, and virtual circuit matching modeling.

## Automation Features

- Segmented frequency sweeps
- Power sweeps
- 9 channels max. with up to 8 traces each
- Limit tests
- Linear/logarithmic sweeps
- Multiple trace formats
- Marker math



# TR1300/1 Specifications<sup>1</sup>

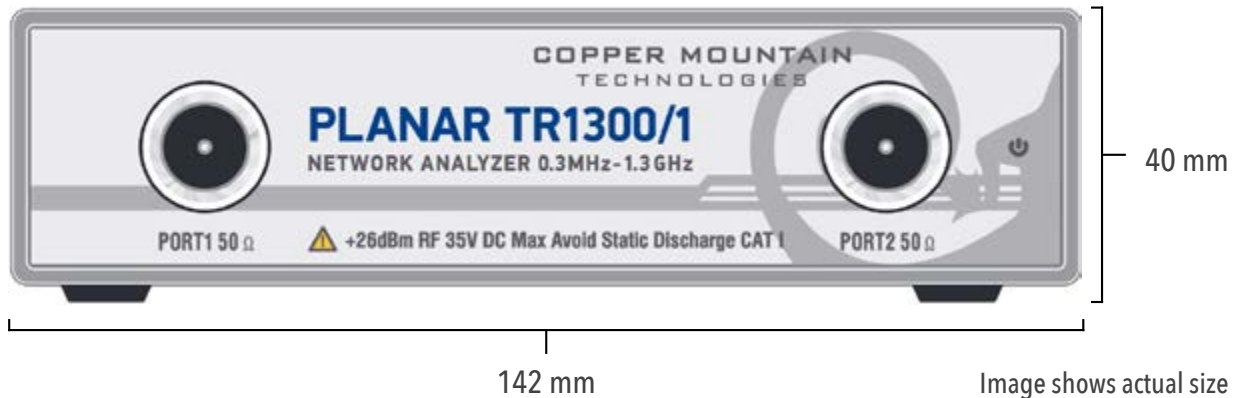

## Primary Specifications

Impedance	50 Ohm
Test port connector	type N, female
Number of test ports	2
Frequency range	300 kHz to 1.3 GHz
Full frequency accuracy	$\pm 5 \cdot 10^{-6}$
Frequency resolution	1 Hz
Number of measurement points	2 to 16,001
Measurement bandwidths (with 1/1.5/2/3/5/7 steps)	10 Hz to 30 kHz
Dynamic range <sup>2</sup>	130 dB (135 dB typ.)

## Measurement Accuracy

Accuracy of transmission measurements <sup>4</sup>	Magnitude / Phase ( $S_{11} = S_{22} = 0$ )	Magnitude / Phase ( $S_{11} = S_{22} = 0.1$ )
+10 dB to +13 dB	$\pm 0.2$ dB / $\pm 2^\circ$	$\pm 0.2$ dB / $\pm 2^\circ$
-50 dB to +10 dB	$\pm 0.1$ dB / $\pm 1^\circ$	$\pm 0.15$ dB / $\pm 1.5^\circ$
-70 dB to -50 dB	$\pm 0.2$ dB / $\pm 2^\circ$	$\pm 0.2$ dB / $\pm 2^\circ$
-85 dB to -70 dB	$\pm 1.0$ dB / $\pm 6^\circ$	$\pm 1.0$ dB / $\pm 6^\circ$
Accuracy of reflection measurements <sup>5</sup>	Magnitude / Phase	
-15 dB to 0 dB	$\pm 0.4$ dB / $\pm 4^\circ$	
-25 dB to -15 dB	$\pm 1.5$ dB / $\pm 7^\circ$	
-35 dB to -25 dB	$\pm 4.0$ dB / $\pm 22^\circ$	
Trace noise magnitude (IF bandwidth 3 kHz)	0.002 dB rms	
Temperature dependence	0.02 dB/°C	

## Effective System Data

300 kHz to 1.3 GHz	
Directivity	45 dB
Source match	40 dB
Load match	28 dB
Reflection tracking	$\pm 0.10$ dB
Transmission tracking	$\pm 0.08$ dB

## Uncorrected System Performance

300 kHz to 1.3 GHz	
Directivity	18 dB
Source match	15 dB
Load match	28 dB

## Test Port Output

Power range	-55 dBm to +3 dBm
Power accuracy	$\pm 1.5$ dB
Power resolution	0.05 dB

[1] All specifications subject to change without notice. [2] The dynamic range is defined as the difference between the specified maximum power level and the specified noise floor. The specification applies at 10 Hz IF bandwidth. [3] Reflection and transmission measurement accuracy applies over the temperature range of  $(73 \pm 9)$  °F or  $(23 \pm 5)$  °C after 40 minutes of warming-up, with less than 1 °C deviation from one-path two-port calibration temperature, at output power of -10 dBm. Frequency points have to be identical for measurement and calibration (no interpolation allowed).

[4] Transmission specifications are based on a matched DUT, and IF bandwidth of 10 Hz. [5] Reflection specifications are based on an isolating DUT. © Copper Mountain Technologies -

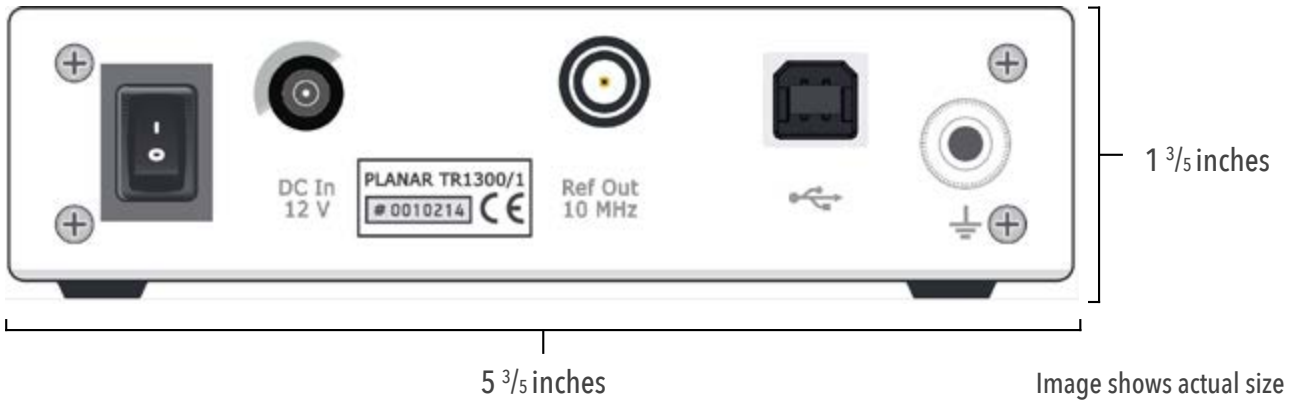

### Test Port Input

Noise floor	-137 dBm/Hz
Damage level	+26 dBm
Damage DC voltage	35 V

### Measurement Speed

Time per point	150 $\mu$ s typ.
----------------	------------------

### Frequency Reference Output

Port	10 MHz Ref Out
Internal reference frequency	10 MHz
Output reference signal level at 50 Ohm impedance	1 dBm to 5 dBm
Connector type	BNC, female

### System & Power

Operating system	Windows 7 and above
CPU frequency	1.0 GHz
RAM	512 MB
Interface	USB 2.0
Connector type	USB B
Power supply	110-240 V, 50/60 Hz
Power consumption	10 W
Input power	9 V DC to 15 V DC
Input power consumption DC	8 W

### Factory Adjustment

Recommended factory adjustment interval	3 years
-----------------------------------------	---------

### Environmental Specifications

Operating temperature	+5 °C to +40 °C (41 °F to 104 °F)
Storage temperature	-50 °C to +70 °C (-58 °F to 158 °F)
Humidity	90 % at 25 °C (77 °F)
Atmospheric pressure	70.0 kPa to 106.7 kPa



# TR5048 Specifications<sup>1</sup>

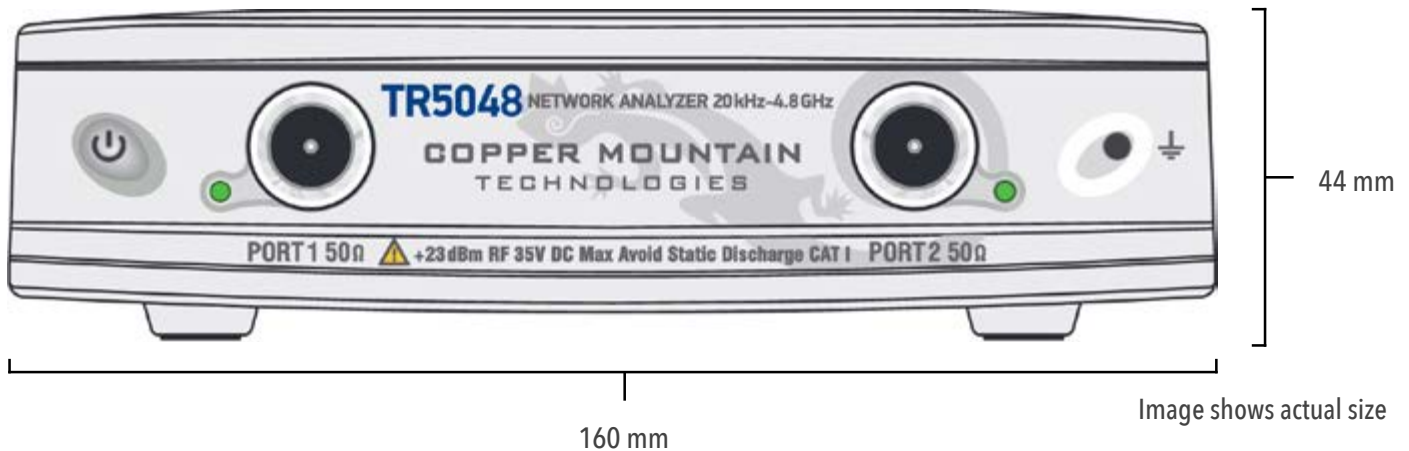

## Primary Specifications

Impedance	50 Ohm
Test port connector	type N, female
Number of test ports	2
Frequency range	20 kHz to 4.8 GHz
Full frequency accuracy	$\pm 5 \cdot 10^{-6}$
Frequency resolution	10 Hz
Number of measurement points	2 to 200,001
Measurement bandwidths (with 1/1.5/2/3/5/7 steps)	1 Hz to 30 kHz
Dynamic range <sup>2</sup>	
20 kHz to 300 kHz	75 dB (100 dB typ.)
300 kHz to 4.8 GHz	120 dB (123 dB typ.)

## Measurement Accuracy

Accuracy of transmission measurements <sup>4</sup>	Magnitude / Phase ( $S_{11} = S_{22} = 0$ )	Magnitude / Phase ( $S_{11} = S_{22} = 0.1$ )
20 kHz to 300 kHz		
-15 dB to +10 dB	$\pm 0.2$ dB / $\pm 2^\circ$	$\pm 0.4$ dB / $\pm 3^\circ$
-35 dB to -15 dB	$\pm 1.0$ dB / $\pm 6^\circ$	$\pm 1.5$ dB / $\pm 7^\circ$
300 kHz to 4.8 GHz		
0 dB to +10 dB	$\pm 0.2$ dB / $\pm 2^\circ$	$\pm 0.3$ dB / $\pm 3^\circ$
-40 dB to 0 dB	$\pm 0.15$ dB / $\pm 1.5^\circ$	$\pm 0.25$ dB / $\pm 2^\circ$
-60 dB to -40 dB	$\pm 0.2$ dB / $\pm 2^\circ$	$\pm 0.3$ dB / $\pm 3^\circ$
-80 dB to -60 dB	$\pm 1.0$ dB / $\pm 6^\circ$	$\pm 1.0$ dB / $\pm 6^\circ$
Accuracy of reflection measurements <sup>5</sup>	Magnitude / Phase	
-15 dB to 0 dB	$\pm 0.4$ dB / $\pm 3^\circ$	
-25 dB to -15 dB	$\pm 1.0$ dB / $\pm 6^\circ$	
-35 dB to -25 dB	$\pm 3.0$ dB / $\pm 20^\circ$	
Trace noise magnitude (IF bandwidth 3 kHz)		
20 kHz to 300 kHz	0.050 dB rms	
300 kHz to 4.8 GHz	0.002 dB rms	
Temperature dependence	0.02 dB/°C	

## Effective System Data

20 kHz to 300 kHz	
Directivity	46 dB
Source match	40 dB
Load match	15 dB
Reflection tracking	$\pm 0.10$ dB
Transmission tracking	$\pm 0.14$ dB
300 kHz to 4.8 GHz	
Directivity	46 dB
Source match	40 dB
Load match	22 dB
Reflection tracking	$\pm 0.10$ dB
Transmission tracking	$\pm 0.14$ dB

## Uncorrected System Performance

20 kHz to 300 kHz	
Directivity	12 dB
Source match	15 dB
Load match	15 dB
300 kHz to 4.8 GHz	
Directivity	15 dB (18 dB typ.)
Source match	15 dB
Load match	22 dB

## Test Port Output

Power range	-50 dBm to +5 dBm
Power accuracy	$\pm 1.0$ dB
Power resolution	0.05 dB
Harmonic distortion <sup>6</sup>	-20 dBc
Non-harmonic spurious <sup>6</sup>	-30 dBc

[1] All specifications subject to change without notice. [2] The dynamic range is defined as the difference between the specified maximum power level and the specified noise floor. The specification applies at 10 Hz IF bandwidth. [3] Reflection and transmission measurement accuracy applies over the temperature range of  $(73 \pm 9)^\circ\text{F}$  or  $(23 \pm 5)^\circ\text{C}$  after 40 minutes of warming-up, with less than  $1^\circ\text{C}$  deviation from one-path two-port calibration temperature, at output power of -5 dBm. Frequency points have to be identical for measurement and calibration (no interpolation allowed). [4] Transmission specifications are based on a matched DUT, and IF bandwidth of 10 Hz. [5] Reflection specifications are based on an isolating DUT. [6] Specification applies over frequency range from 300 kHz to upper frequency limit, at output power of 0 dBm. © Copper Mountain Technologies Rev. 2019Q3

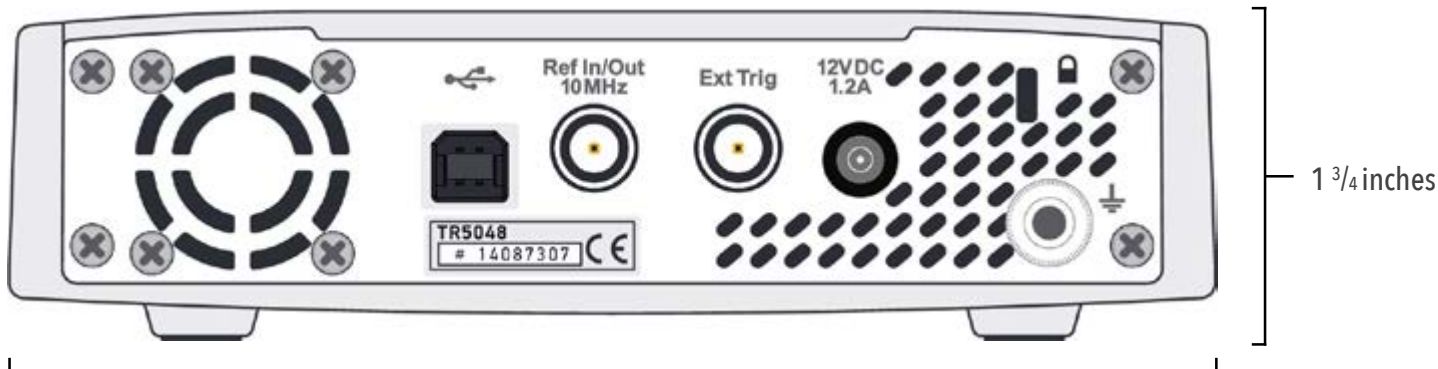

6 <sup>3</sup>/<sub>10</sub> inches

Image shows actual size

### Test Port Input

<b>Noise floor</b>	
20 kHz to 300 kHz	-80 dBm/Hz
300 kHz to 4.8 GHz	-125 dBm/Hz
<b>Damage level</b>	+23 dBm
<b>Damage DC voltage</b>	35 V

### Measurement Speed

<b>Time per point</b>	250 $\mu$ s typ.
<b>Port switchover time</b>	10 ms

### Frequency Reference Input

<b>Port</b>	10 MHz Ref In/Out
<b>External reference frequency</b>	10 MHz
<b>Input level</b>	-1 dBm to 5 dBm
<b>Input impedance</b>	50 Ohm
<b>Connector type</b>	BNC, female

### Frequency Reference Output

<b>Port</b>	10 MHz Ref In/Out
<b>Internal reference frequency</b>	10 MHz
<b>Output reference signal level at 50 Ohm impedance</b>	1 dBm to 5 dBm
<b>Connector type</b>	BNC, female

### Frequency Trigger Input

<b>Port</b>	Ext Trig
<b>Input level</b>	
Low threshold voltage	0.5 V
High threshold voltage	2.7 V
<b>Input level range</b>	0 V to + 5 V
<b>Pulse width</b>	$\geq$ 2 $\mu$ s
<b>Polarity</b>	positive or negative
<b>Input impedance</b>	$\geq$ 10 kOhm
<b>Connector type</b>	BNC, female

### Frequency Trigger Output

<b>Port</b>	Ext Trig
<b>Maximum output current</b>	20 mA
<b>Output level</b>	
Low level voltage	0.0 V
High level voltage	3.5 V
<b>Polarity</b>	positive or negative
<b>Connector type</b>	BNC, female

### System & Power

<b>Operating system</b>	Windows 7 and above
<b>CPU frequency</b>	1.0 GHz
<b>RAM</b>	512 MB
<b>Interface</b>	USB 2.0
<b>Connector type</b>	USB B
<b>Power supply</b>	110-240 V, 50/60 Hz
<b>Power consumption</b>	12 W
<b>Input power</b>	9 V DC to 15 V DC
<b>Input power consumption DC</b>	10 W

### Factory Adjustment

<b>Recommended factory adjustment interval</b>	3 years
------------------------------------------------	---------

### Environmental Specifications

<b>Operating temperature</b>	+5 $^{\circ}$ C to +40 $^{\circ}$ C (41 $^{\circ}$ F to 104 $^{\circ}$ F)
<b>Storage temperature</b>	-50 $^{\circ}$ C to +70 $^{\circ}$ C (-58 $^{\circ}$ F to 158 $^{\circ}$ F)
<b>Humidity</b>	90 % at 25 $^{\circ}$ C (77 $^{\circ}$ F)
<b>Atmospheric pressure</b>	70.0 kPa to 106.7 kPa

# TR7530 Specifications<sup>1</sup>

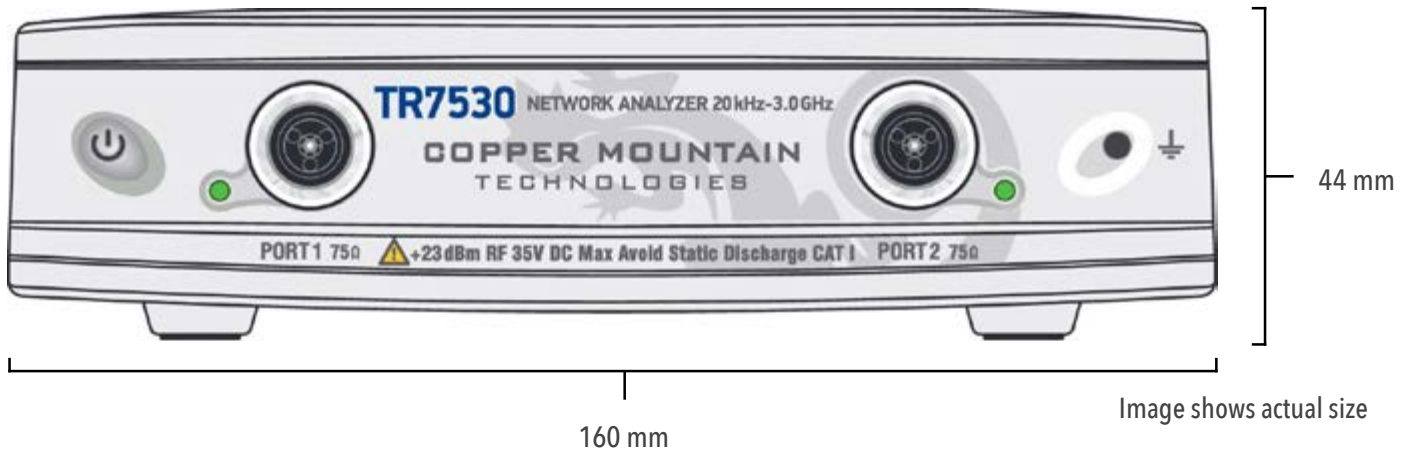

## Primary Specifications

Impedance	75 Ohm
Test port connector	type N, female
Number of test ports	2
Frequency range	20 kHz to 3.0 GHz
Full frequency accuracy	$\pm 5 \cdot 10^{-6}$
Frequency resolution	10 Hz
Number of measurement points	2 to 200,001
Measurement bandwidths (with 1/1.5/2/3/5/7 steps)	1 Hz to 30 kHz
Dynamic range <sup>2</sup>	
20 kHz to 300 kHz	75 dB (100 dB typ.)
300 kHz to 3.0 GHz	120 dB (123 dB typ.)

## Measurement Accuracy

Accuracy of transmission measurements <sup>4</sup>	Magnitude / Phase ( $S_{11} = S_{22} = 0$ )	Magnitude / Phase ( $S_{11} = S_{22} = 0.1$ )
20 kHz to 300 kHz		
-15 dB to +10 dB	$\pm 0.2$ dB / $\pm 2^\circ$	$\pm 0.4$ dB / $\pm 3^\circ$
-35 dB to -15 dB	$\pm 1.0$ dB / $\pm 6^\circ$	$\pm 1.5$ dB / $\pm 7^\circ$
300 kHz to 3.0 GHz		
0 dB to +10 dB	$\pm 0.2$ dB / $\pm 2^\circ$	$\pm 0.3$ dB / $\pm 3^\circ$
-40 dB to 0 dB	$\pm 0.15$ dB / $\pm 1.5^\circ$	$\pm 0.25$ dB / $\pm 2^\circ$
-60 dB to -40 dB	$\pm 0.2$ dB / $\pm 2^\circ$	$\pm 0.3$ dB / $\pm 3^\circ$
-80 dB to -60 dB	$\pm 1.0$ dB / $\pm 6^\circ$	$\pm 1.0$ dB / $\pm 6^\circ$
Accuracy of reflection measurements <sup>5</sup>	Magnitude / Phase	
-15 dB to 0 dB	$\pm 0.4$ dB / $\pm 3^\circ$	
-25 dB to -15 dB	$\pm 1.0$ dB / $\pm 6^\circ$	
-35 dB to -25 dB	$\pm 3.0$ dB / $\pm 20^\circ$	
Trace noise magnitude (IF bandwidth 3 kHz)		
20 kHz to 300 kHz	0.050 dB rms	
300 kHz to 3.0 GHz	0.002 dB rms	
Temperature dependence	0.02 dB/°C	

## Effective System Data

20 kHz to 3.0 GHz		
Directivity		46 dB
Source match		40 dB
Load match		15 dB
Reflection tracking		$\pm 0.10$ dB
Transmission tracking		$\pm 0.14$ dB
300 kHz to 3.0 GHz		
Directivity		46 dB
Source match		40 dB
Load match		22 dB
Reflection tracking		$\pm 0.10$ dB
Transmission tracking		$\pm 0.14$ dB

## Uncorrected System Performance

20 kHz to 300 kHz		
Directivity		12 dB
Source match		15 dB
Load match		15 dB
300 kHz to 3.0 GHz		
Directivity		15 dB (18 dB typ.)
Source match		15 dB
Load match		22 dB

## Test Port Output

Power range	-50 dBm to +5 dBm
Power accuracy	$\pm 1.0$ dB
Power resolution	0.05 dB
Harmonic distortion <sup>6</sup>	-20 dBc
Non-harmonic spurious <sup>6</sup>	-30 dBc

[1] All specifications subject to change without notice. [2] The dynamic range is defined as the difference between the specified maximum power level and the specified noise floor. The specification applies at 10 Hz IF bandwidth. [3] Reflection and transmission measurement accuracy applies over the temperature range of  $(73 \pm 9)^\circ\text{F}$  or  $(23 \pm 5)^\circ\text{C}$  after 40 minutes of warming-up, with less than  $1^\circ\text{C}$  deviation from one-path two-port calibration temperature, at output power of -5 dBm. Frequency points have to be identical for measurement and calibration (no interpolation allowed). [4] Transmission specifications are based on a matched DUT, and IF bandwidth of 10 Hz. [5] Reflection specifications are based on an isolating DUT. [6] Specification applies over frequency range from 300 kHz to upper frequency limit, at output power of 0 dBm. © Copper Mountain Technologies Rev. 2019Q3

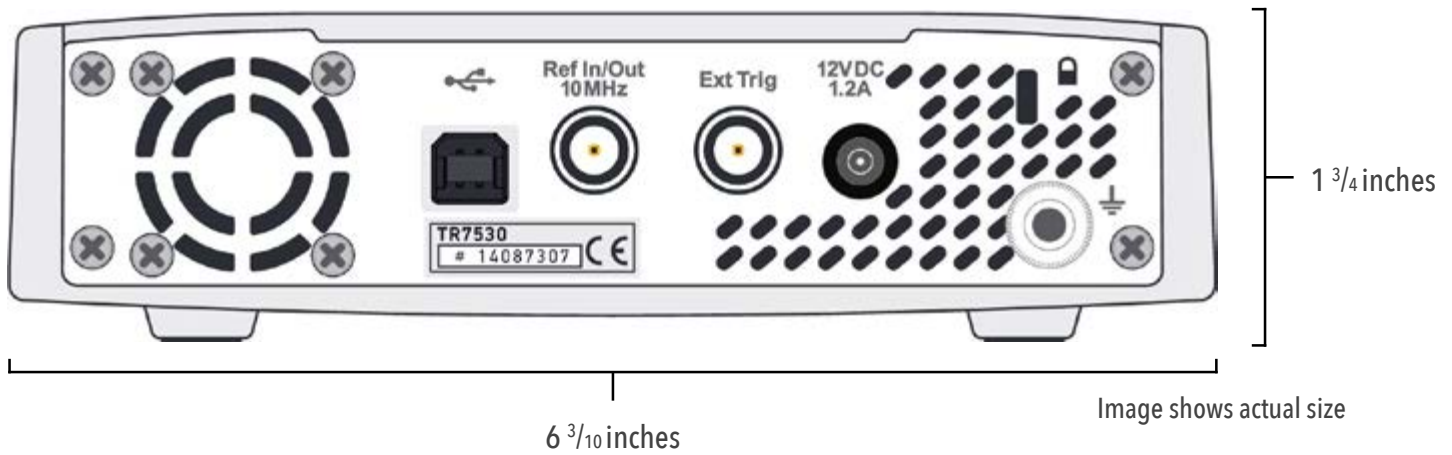

### Test Port Input

Noise floor	
20 kHz to 300 kHz	-80 dBm/Hz
300 kHz to 3.0 GHz	-125 dBm/Hz
Damage level	+23 dBm
Damage DC voltage	35 V

### Measurement Speed

Time per point	250 $\mu$ s typ.
Port switchover time	10 ms

### Frequency Reference Input

Port	10 MHz Ref In/Out
External reference frequency	10 MHz
Input level	-1 dBm to 5 dBm
Input impedance	50 Ohm
Connector type	BNC, female

### Frequency Reference Output

Port	10 MHz Ref In/Out
Internal reference frequency	10 MHz
Output reference signal level at 50 Ohm impedance	1 dBm to 5 dBm
Connector type	BNC, female

### Frequency Trigger Input

Port	Ext Trig
Input level	
Low threshold voltage	0.5 V
High threshold voltage	2.7 V
Input level range	0 V to + 5 V
Pulse width	$\geq 2 \mu$ s
Polarity	positive or negative
Input impedance	$\geq 10$ kOhm
Connector type	BNC, female

### Frequency Trigger Output

Port	Ext Trig
Maximum output current	20 mA
Output level	
Low level voltage	0.0 V
High level voltage	3.5 V
Polarity	positive or negative
Connector type	BNC, female

### System & Power

Operating system	Windows 7 and above
CPU frequency	1.0 GHz
RAM	512 MB
Interface	USB 2.0
Connector type	USB B
Power supply	110-240 V, 50/60 Hz
Power consumption	12 W
Input power	9 V DC to 15 V DC
Input power consumption DC	10 W

### Factory Adjustment

Recommended factory adjustment interval	3 years
-----------------------------------------	---------

### Environmental Specifications

Operating temperature	+5 °C to +40 °C (41 °F to 104 °F)
Storage temperature	-50 °C to +70 °C (-58 °F to 158 °F)
Humidity	90 % at 25 °C (77 °F)
Atmospheric pressure	70.0 kPa to 106.7 kPa

Technology is supposed to move. It's supposed to change and update and progress. It's not meant to sit stagnant year after year simply because that's how things have always been done.

The engineers at Copper Mountain Technologies are creative problem solvers. They know the people using VNAs don't just need one giant machine in a lab. They know that VNAs are needed in the field, requiring portability and flexibility. Data needs to be quickly transferred, and a test setup needs to be easily automated and recalled for various applications. The engineers at Copper Mountain Technologies are rethinking the way VNAs are developed and used.

Copper Mountain Technologies' VNAs are designed to work with the Windows or Linux PC you already use via USB interface. After installing the test software, you have a top-quality VNA at a fraction of the cost of a traditional analyzer. The result is a faster, more effective test process that fits into the modern workspace. This is the creativity that makes Copper Mountain Technologies stand out above the crowd.

We're creative. We're problem solvers.



	TR1300/1	TR5048	TR7530
Frequency Range	300 kHz to 1.3 GHz	20 kHz to 4.8 GHz	20 kHz to 3 GHz
S-parameters	$S_{11}$ , $S_{21}$	$S_{11}$ , $S_{21}$	$S_{11}$ , $S_{21}$
Port Impedance	50 Ohm	50 Ohm	75 Ohm